

DWM COPELAND SEMI-HERMETIC COMPRESSORS CAPACITY CONTROL

1 Compressor Capacity Modulation for Air Conditioning & Refrigeration Systems

1.1 Capacity Control

Compressors in the higher capacity range need some form of capacity control to accommodate varying refrigeration load. The capacity control kit supplied by DWM Copeland will reduce the refrigeration capacity along with a similar proportional reduction in Power Input. This ensures optimum performance even in part load.

Capacity control is also required when the condensing pressure falls with a drop in ambient air temperature. The compressor suction condition, refrigerant volume and mass flow rate will remain unchanged. The capacity will increase due to the increase in Δh , along with the increase in volumetric efficiency, see the pH chart below.

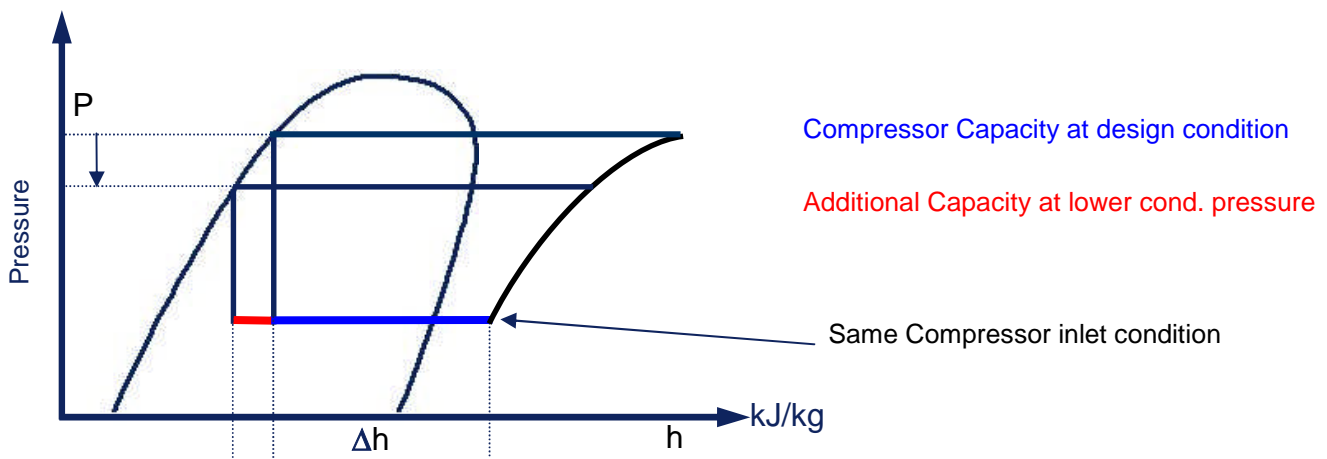

1.2 Methods of Capacity Control

There are many methods of capacity control for Semi-Hermetic compressors but DWM Copeland use the “Blocked Suction method” and for the D3D Over Re-expansion method known as Moduload.

Note: Oil circulation in systems with capacity control is more critical

Advantages
 Reduces the starting frequency of the compressors
 Ensure satisfactory operation with optimal capacity data
 Energy cost saving even at partial-load

Disadvantages
 Motor is less cooled (refrigerant flow reduced)
 Restriction of the application range
 Oil circulation is more critical

2 DWM Copeland Semi-Hermetic S Series Models Capacity Control

For 4S, 6S and 8S cylinder compressors a mechanical capacity control is available.

Be aware that capacity controlled operation changes the application range of the compressor.

2.1 Capacity Control

The 4S, 6S & 8S compressors have an internal capacity control, they work on the principle of blocking the suction gas passage to two or more cylinders. They require the use of a special cylinder head and a control valve with solenoid coil. These items may be ordered installed at the factory or in a kit form for later installation.

The suction port of the valve plate will be closed by a control piston (blocked suction). To prevent transport damage the solenoid valve is supplied loose and the cylinder head is fitted with a shipping plate, therefore the shipping plate with gasket must be removed and the solenoid valve with new gasket mounted.

Do not put the compressor into operation with the shipping plate this could result in erratic operation of the control piston and inadequate cooling capacity.

2.1.1 Inactive Capacity Control

These compressors can be ordered with inactive capacity control. There is a gasket under the shipping plate that allows operation on 100% capacity. To convert to active capacity control all that is needed is to fit the solenoid valve with the active gasket instead of the shipping plate.

2.1.2 Normal Operation (Full load)

When the solenoid coil is not energised the top of the unloader piston is vented to suction pressure allowing the piston to be lifted by means of a spring. The compressor draws gas from all cylinders and reaches full cooling capacity.

2.1.3 Capacity Controlled Operation (Part load)

When the solenoid coil is energised the top of the unloader piston is forced down with discharge gas pressure thereby blocking the suction gas passage into the cylinders thus enabling the compressor to run with reduced capacity.



Gasket - Cylinder head for capacity control – Internal view – External view

2.1.4 Position of Capacity Control

D4S

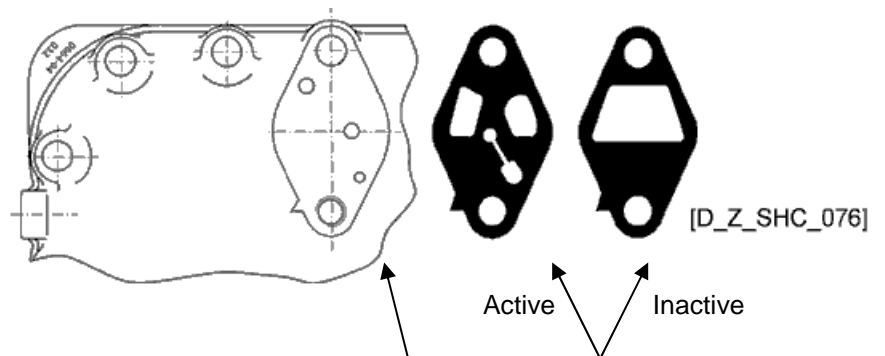
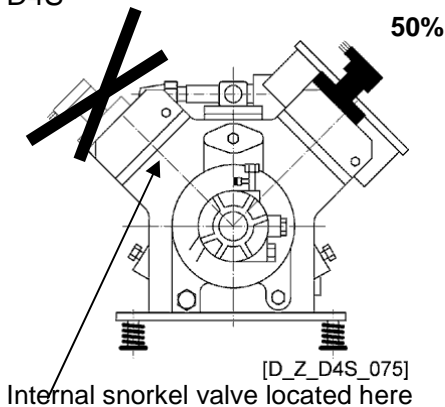

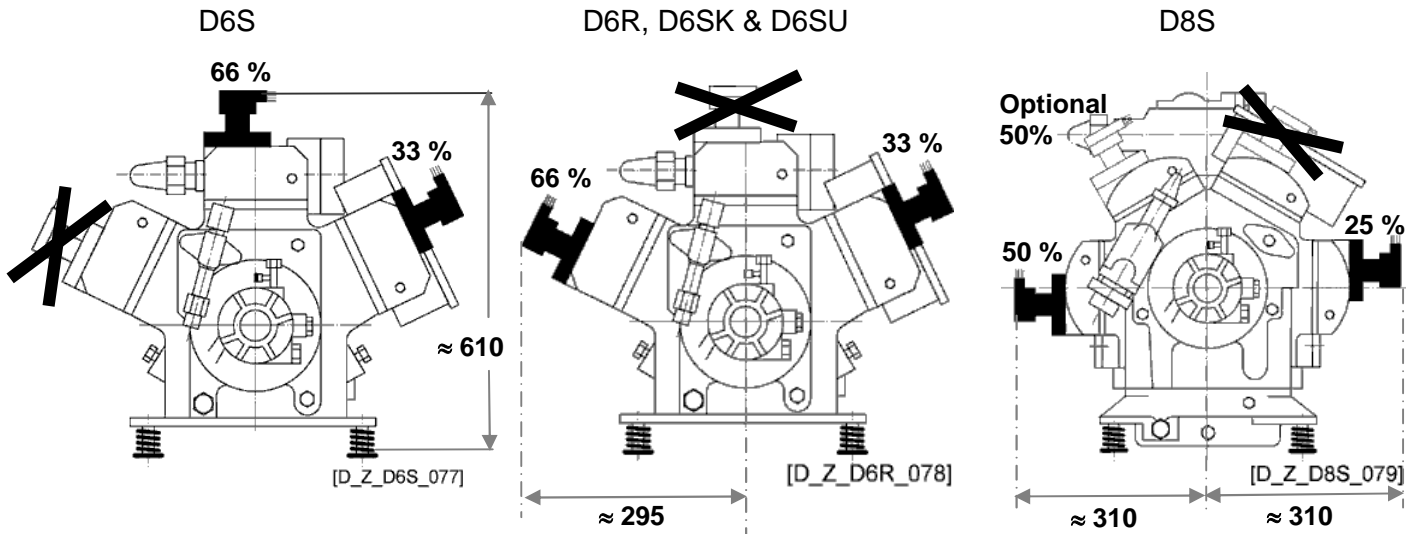

Capacity control must be fitted in the following positions:

- D4S 50% terminal box side
- D6SK 1st step 33% terminal box side
- D6SK 2nd step 66% lower cylinder head on discharge valve side
- D6S 1st step 33% terminal box side
- D6S 2nd step 66% upper cylinder head
- D8S 1st step 25% lower cylinder head on terminal box side
- D8S 2nd step 50% lower cylinder head on discharge valve side

Retrofit Kit includes:

- 1 x Cylinder head for capacity control
- 1 x Gasket kit
- 1 x Solenoid valve assembly (No 703 RB 001)
- 2 x Mounting screws

Voltages of the solenoid valve coil:

- 24V D.C.
- 24V / 1~ / 50 / 60 Hz
- 208-240V / 1~ / 50 / 60 Hz
- 120V / 1~ / 50 / 60 Hz

Protection class: IP 55 (evaluation according to IEC 34)

Selection of Capacity Control

D4S - D8S

R 22

Compressor	Number of Cylinders with Capacity Control	Capacity Regulating Step			Remaining Refrigeration Capacity % (average values)	Remaining Power Input % (average values)	Diagram No
		0	1	2			
					Application Range		
					H / M	H / M	
D4SA-2000	2	100%	50%		51	53	1
D4SH-2500	2	100%	50%		51	53	
D4SJ-3000	2	100%	50%		51	53	
D6SA-3000	2 / 4	100%	66%	33%	67/34	68/34	
D6SH-3500	2 / 4	100%	66%	33%	67/34	68/34	
D6SJ-4000	2 / 4	100%	66%	33%	67/34	68/34	2A
D8SH-5000	2 / 4	100%	75%	50%	76/53	79/57	
D8SJ-6000	2 / 4	100%	75%	50%	76/53	79/57	
D8SK-7000	2 / 4	100%	75%	50%	76/53	79/57	

Application limit: see data sheets and application diagrams
 H = high temperature
 M = medium temperature

2.2 Application Range – R22

2.2.1 D4SA / H / J & D6SA / H / J

Diagram 1 Suction gas temperature 25 °C

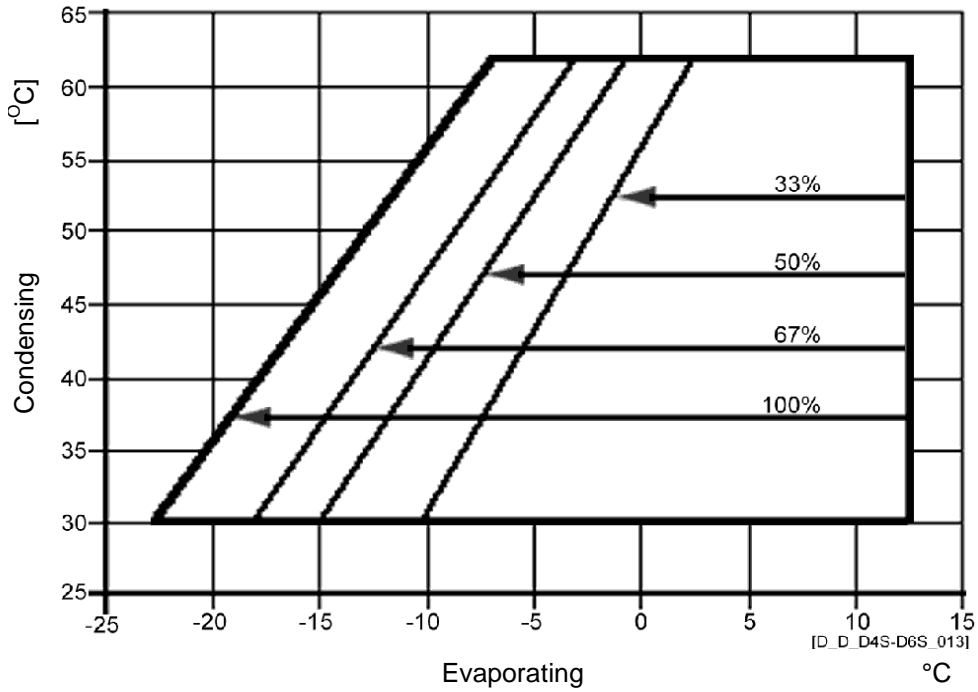

2.2.2 D8SH / J

Diagram 2A Suction gas temperature 25°C

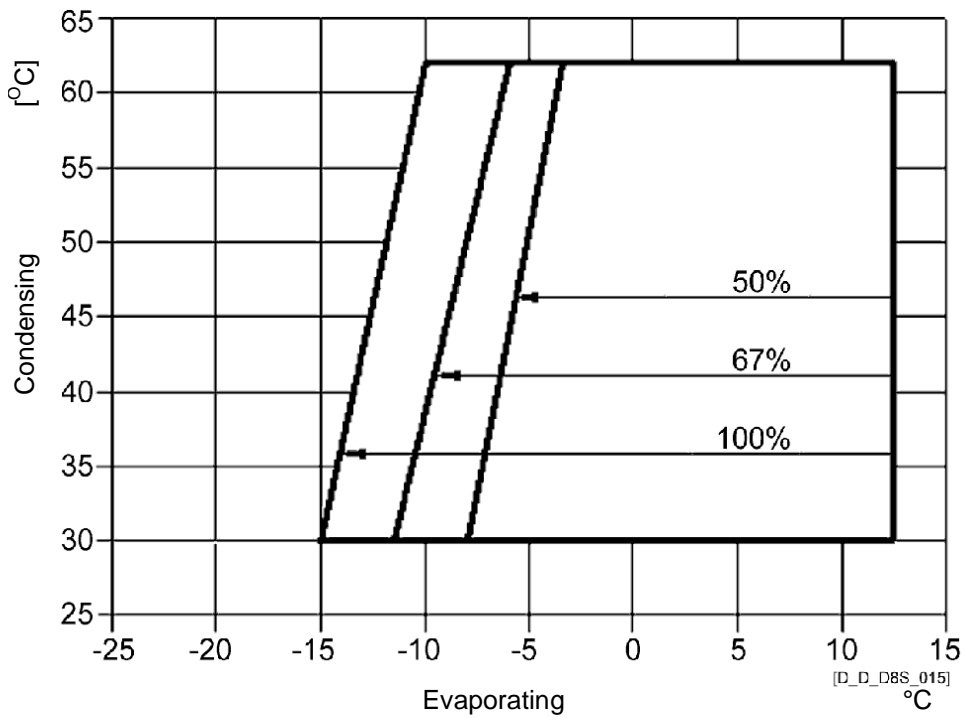

2.2.3 D8SK – 7000

Diagram 2B Suction gas temperature 25°C

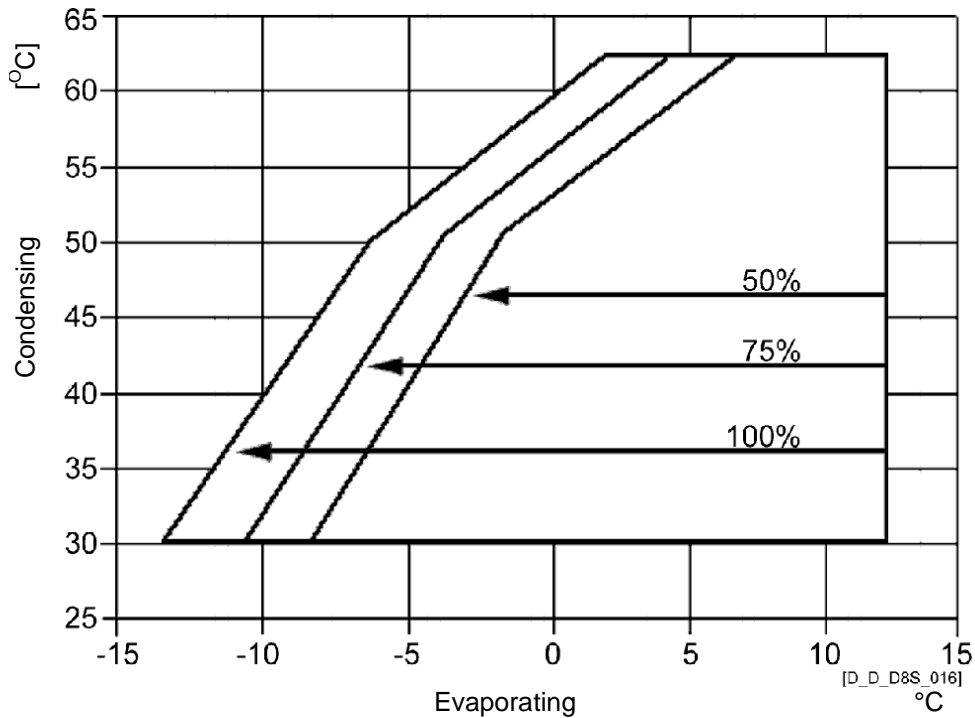

2.3 Selection of Capacity Control

D4S - D8S

R 407C (mid-point)

Compressor	Number of Cylinders with Capacity Control	Capacity Regulating Step			Remaining Refrigeration Capacity % (average values)		Remaining Power Input % (average values)		Diagram No
		0	1	2	Application Range				
					H / M	H / M			
D4SA-200X	2	100%	50%		51	53	3		
D4SH-250X	2	100%	50%		51	53			
D4SJ-300X	2	100%	50%		51	53			
D6SA-300X	2 / 4	100%	66%	33%	67/34	68/34			
D6SH-350X	2 / 4	100%	66%	33%	67/34	68/34			
D6SJ-400X	2 / 4	100%	66%	33%	67/34	68/34			
D8SH-500X	2 / 4	100%	75%	50%	76/53	79/57	4		
D8SJ-600X	2 / 4	100%	75%	50%	76/53	79/57	5		
D8SK-700X	2 / 4	100%	75%	50%	76/53	79/57			

Application limit: see data sheets and application diagrams

H = high temperature

M = medium temperature

D_T_SHC_030

2.4 Application Range – R407C mid-point

2.4.1 D4SA / H / J & D6SA / H / J

Diagram 3 Suction gas temperature 25°C

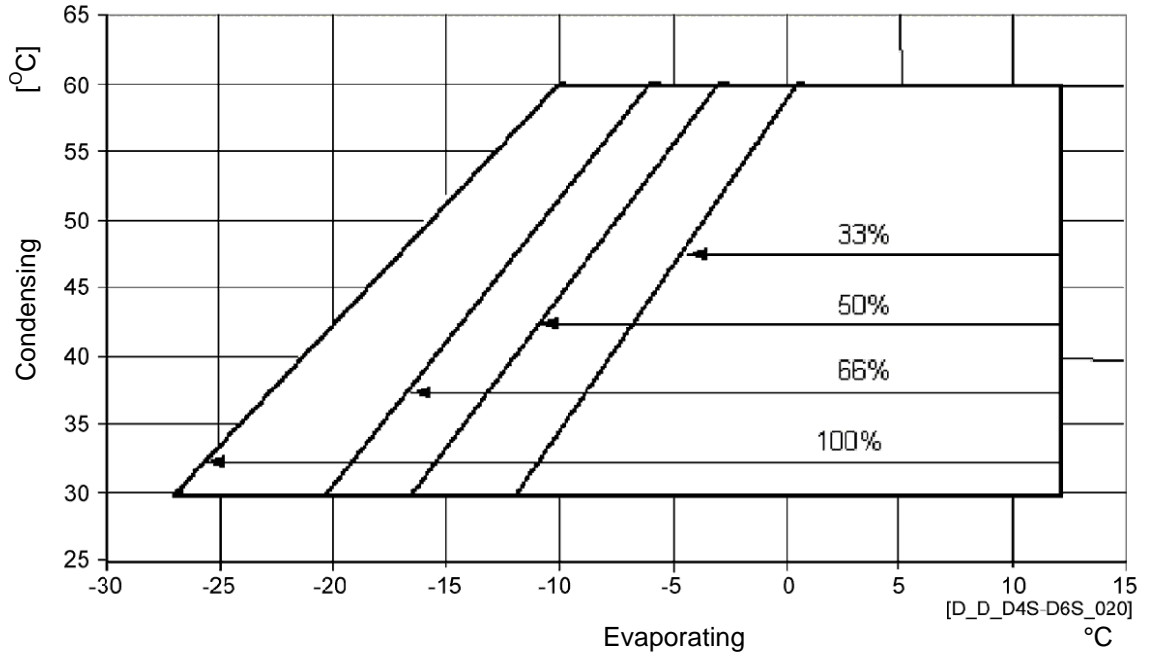

2.4.2 D8SH / J

Diagram 4 Suction gas temperature 25°C

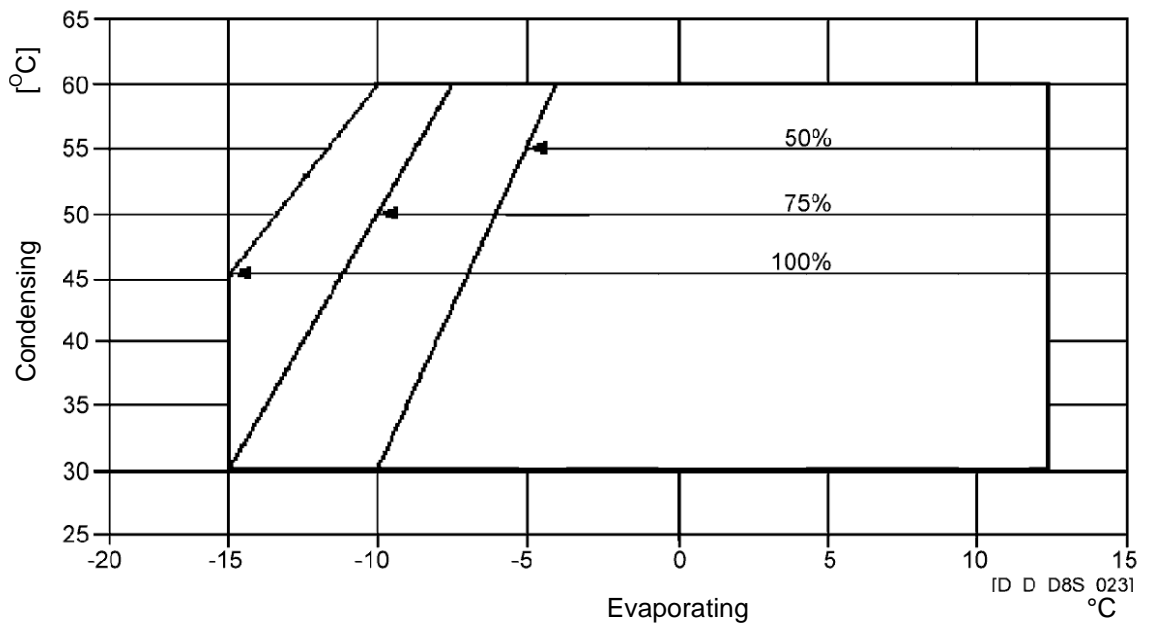

2.4.3 D8SK-700X

Diagram 5 Suction gas temperature 25°C

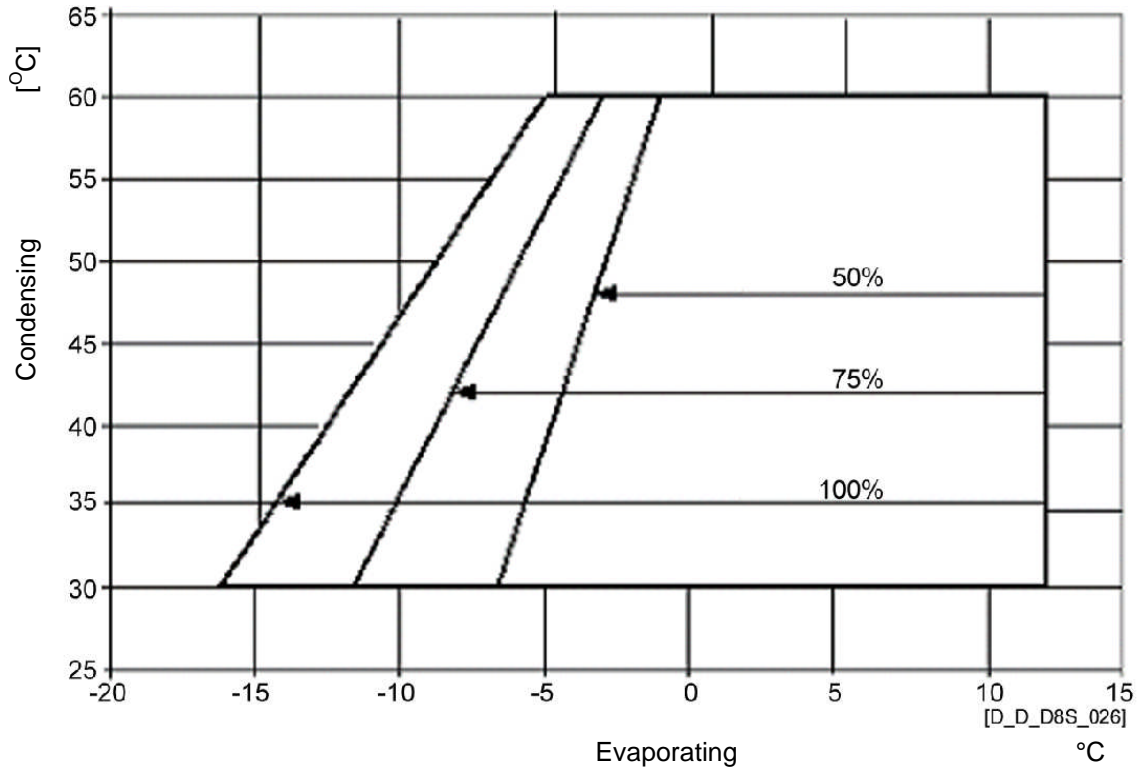

2.5 Selection of Capacity Control

D4S - D8S

R 404A

Compressor	Number of Cylinders with Capacity Control	Capacity Regulating Steps			Remaining Refrigeration Capacity % (average values)			Remaining Power Input % (average values)			Diagram No
		0	1	2	Application Range						
					H	M	L	H	M	L	
D4SF-100X	2	100%	50%				52			59	6 & 7
D4SL-150X	2	100%	50%				52			59	
D4ST-200X	2	100%	50%				52			59	
D4SA-200X	2	100%	50%		51	52		53	59		8 & 9
D4SH-250X	2	100%	50%		51	52		53	59		
D4SJ-300X	2	100%	50%		51	52		53	59		
D6SF-200X	2 / 4	100%	66%	33%			68/34			70/41	6 & 7
D6SL-250X	2 / 4	100%	66%	33%			68/34			70/41	
D6ST-320X	2 / 4	100%	66%	33%			68/34			70/41	
D6SU-400X	2 / 4	100%	66%	33%			68/34			70/41	8 & 9
D6SA-300X	2 / 4	100%	66%	33%	67/34	68/34		68/36	70/41		
D6SH-350X	2 / 4	100%	66%	33%	67/34	68/34		68/36	70/41		
D6SJ-400X	2 / 4	100%	66%	33%	67/34	68/34		68/36	70/41		
D8SH-370X	2 / 4	100%	75%	50%	76/53	76/53		79/56	80/58		
D8SJ-450X	2 / 4	100%	75%	50%	76/53	76/53		79/56	80/58		
D8SH-500X	2 / 4	100%	75%	50%	76/53	76/53		79/56	80/58		
D8SJ-600X	2 / 4	100%	75%	50%	76/53	76/53		79/56	80/58		

Application limit: see data sheets and application diagrams

H = high temperature
M = medium temperature
L = low temperature

2.6 Application Range - R404A

2.6.1 D4SF / L / T & D6SF / L / T / U

Diagram 6: Suction gas temperature 25°C

Low Temperature WITH Additional Cooling (Fan)

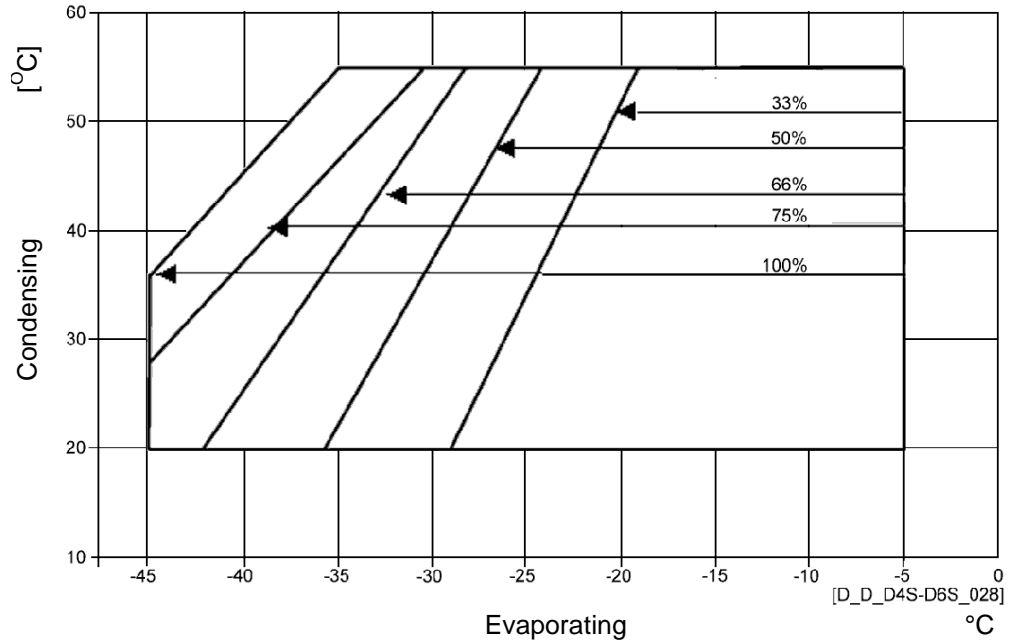
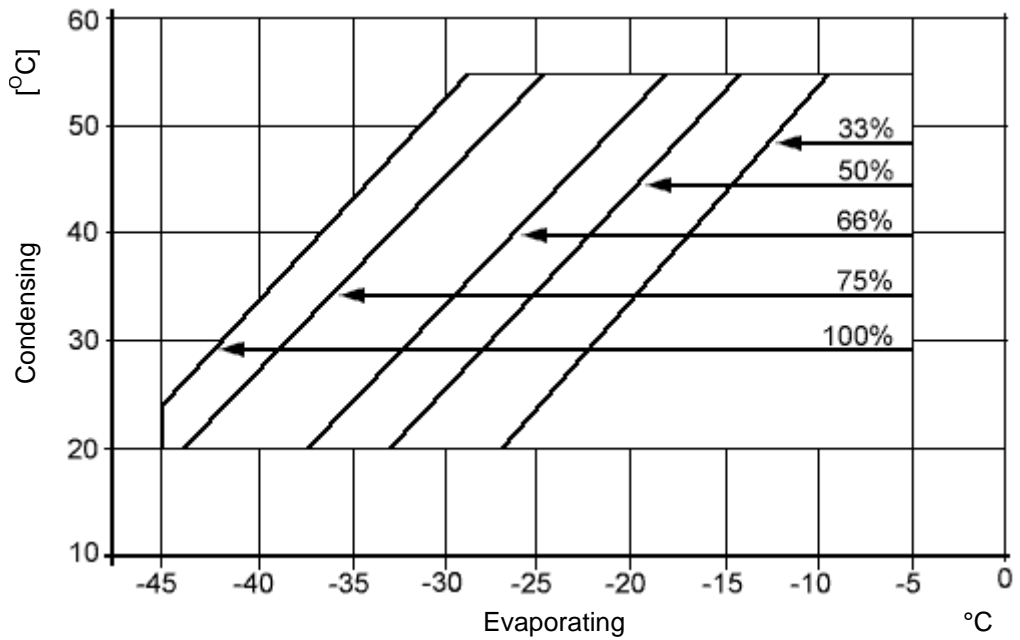

Diagram 7: Suction gas temperature 25°C

Low Temperature WITHOUT Additional Cooling (Fan)



2.6.2 D4SA / H / J & D6SA / H / J & D8SH / J

Diagram 8: Suction gas temperature 25°C

Medium Temperature WITH Additional Cooling (Fan)

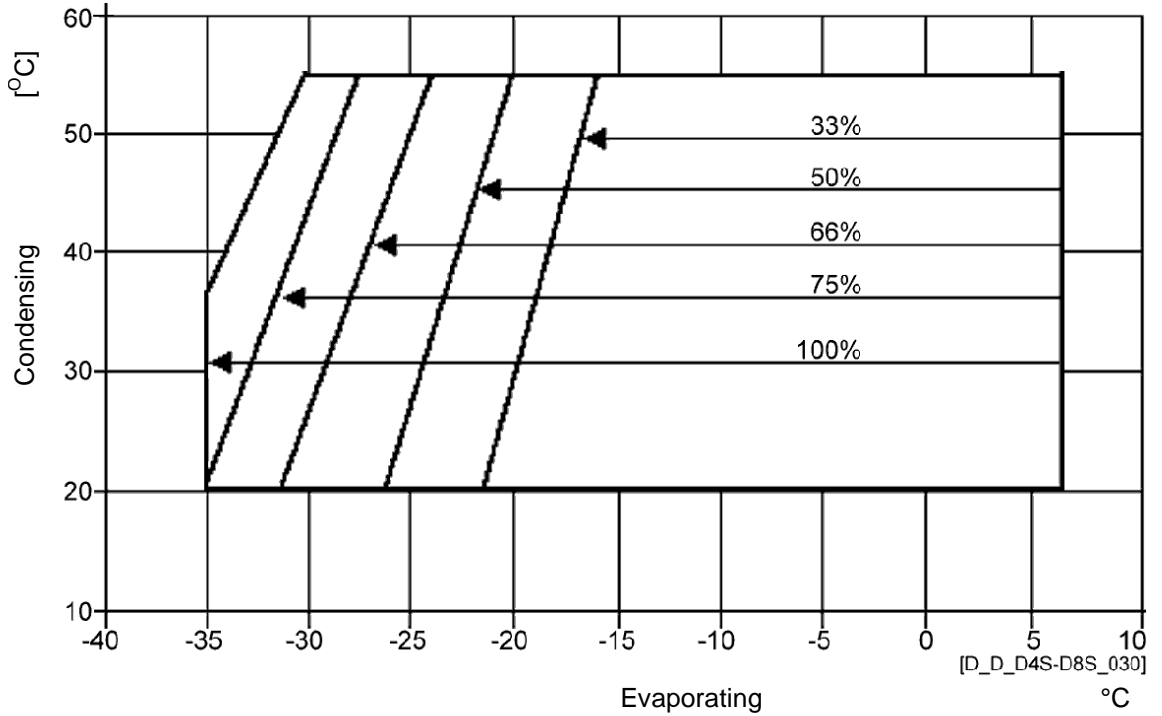
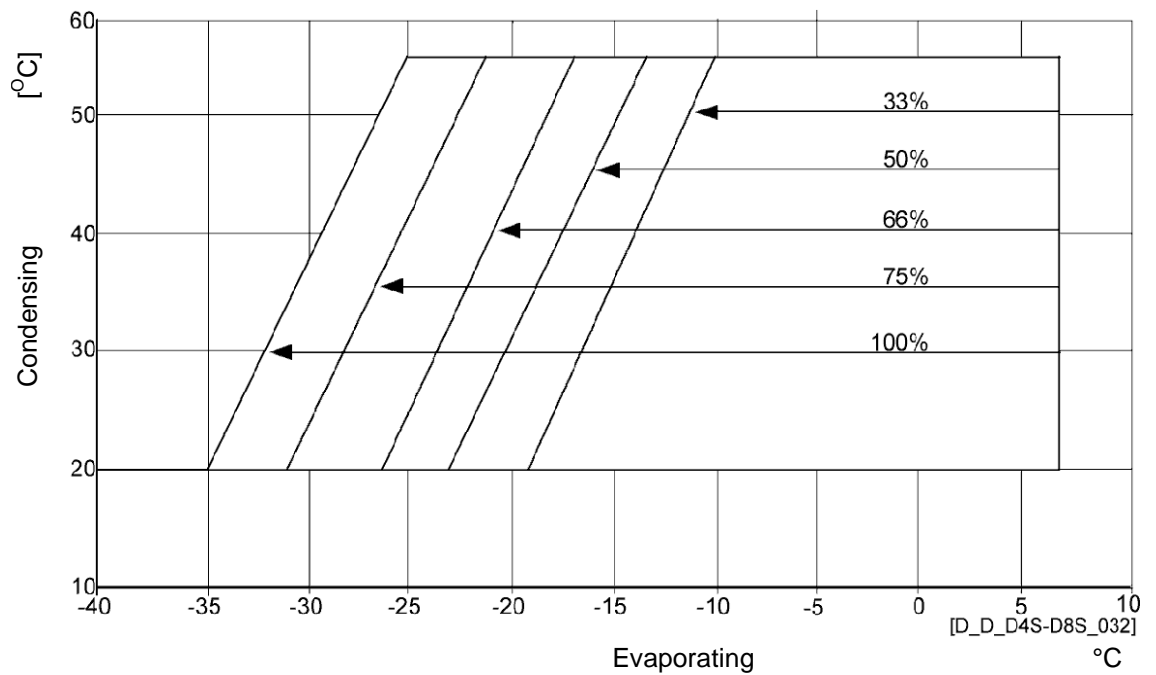

Diagram 9 Suction gas temperature 25°C

Medium Temperature WITHOUT Additional Cooling (Fan)



3 DWM Copeland Semi-Hermetic Discus Models Capacity Control

All Discus model compressors can be equipped with capacity control. When the compressor is operated using capacity control the application range changes.

To prevent transport damage the solenoid valves are supplied loose with the compressor, and the cylinder head is fitted with a shipping plate. The shipping plate and the gasket must be removed. Then the solenoid valve must be mounted using the gasket supplied. Torque to 58-69 Nm.

A retrofit kit is available. The kit does not contain the valve-plate to body gasket. This must be ordered separately. The gasket thickness is marked on the gasket itself ("X"). When ordering please state refrigerant. For conversion kits see spare parts list, the kit contains mounting instructions and a complete bill of material.

3.1 Moduload for D3D Compressors

Moduload is an efficient capacity control based on the principle of adjustable clearance volume. The capacity control kit will reduce both the refrigeration capacity and the power input in almost the same proportion, which ensures optimum performance even in part load.

The solenoid valve may be energized by a thermostat, a pressure control switch or a multiple contact switch. When the solenoid valve is energized the three control pistons are loaded with the evaporator pressure via the opened connection to the suction side. The spring power pushes the three control pistons upwards, thus increasing the clearance volume.

There are two different versions of Moduload:

1. Suitable for HFC refrigerants R404A/R507 and R134a with the relevant refrigerant oils approved by COPELAND.;
2. Suitable for R22 and for the approved refrigerant oils

MODULOAD should not be fitted on compressors with DEMAND COOLING.

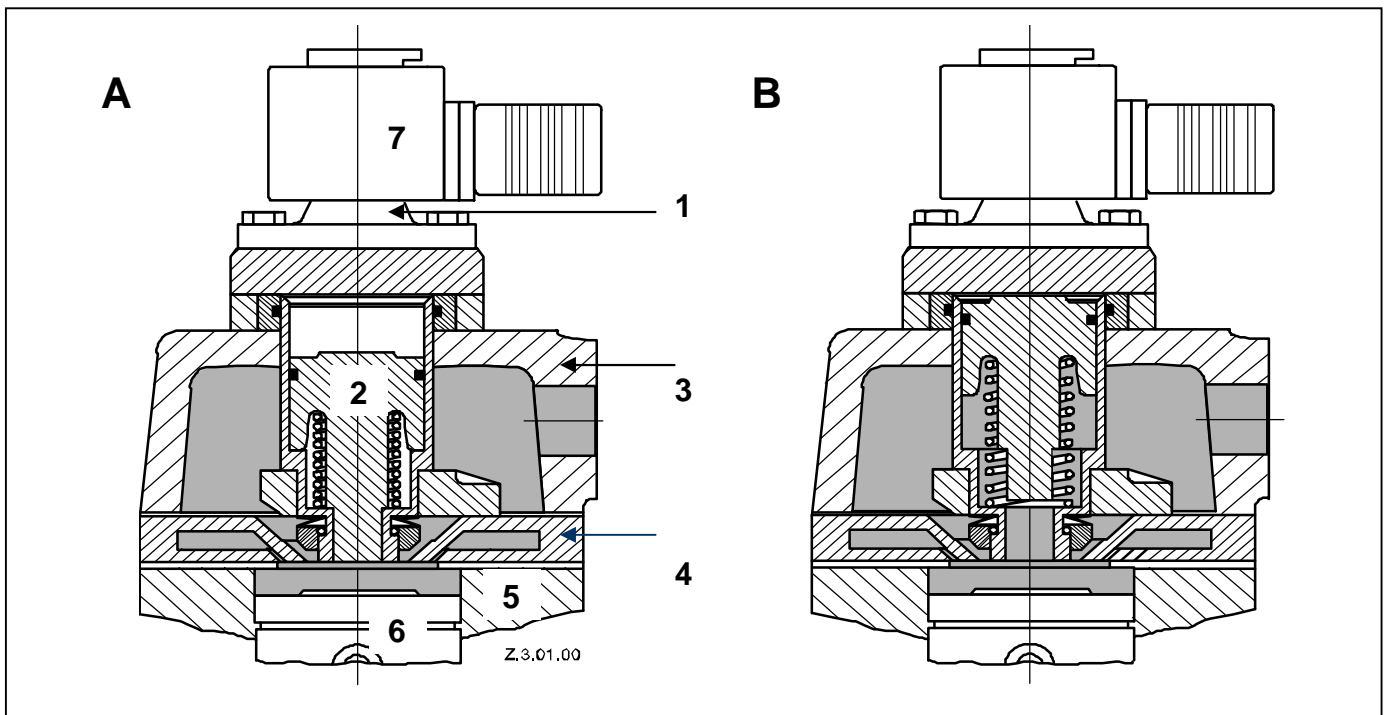

A full-load operation

B part load operation

- 1 Solenoid coil 2 Control piston 3 Cylinder head 4 Valve plate 5 Compressor body 6 piston

3.2 D3D Capacity Control Selection Tables for Moduload

Compressor with MODULOAD	Refrigerant	Range	Diagram	Compressor with MODULOAD	Refrigerant	Range	Diagram
D3DA*-50XH D3DC*-75XH D3DS*-100XH	R 134a	HM	1	D3DA*-50X L D3DC*-75X L D3DS*-100X L	R404A	LXZ	4
D3DA*-75XH D3DC*-100XH D3DS*-150XH	R 134a	HH	2	D3DA*-750H D3DC*-1000H D3DS*-1500H	R 22	HM	5
D3DA*-75XH D3DC*-100XH D3DS*-150XH	R 404A	HM	3				

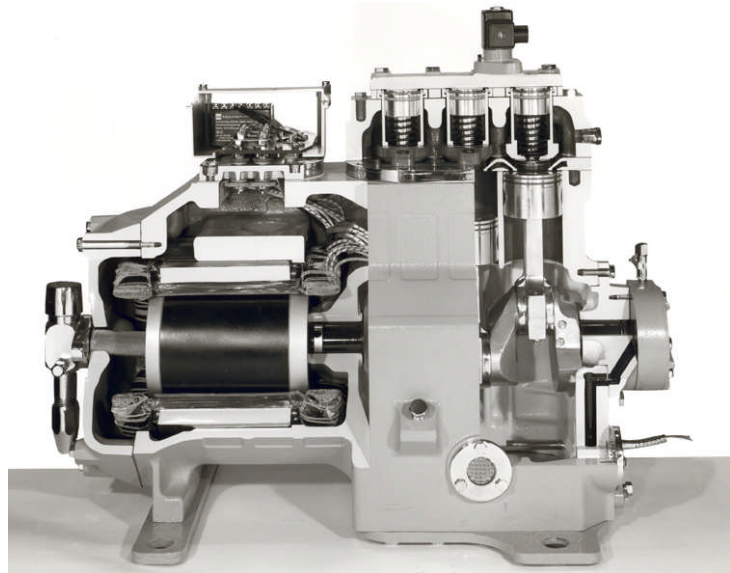
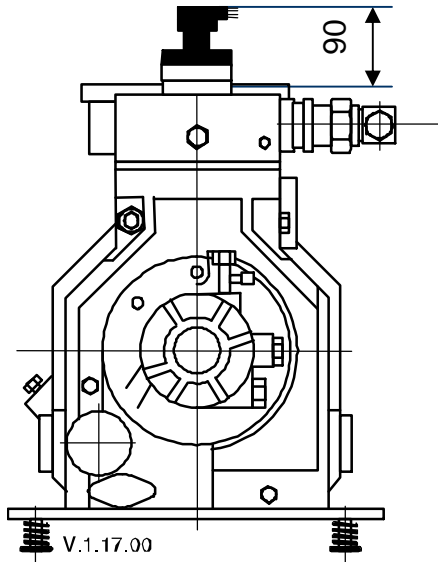

Voltages of the solenoid valve coil:
 24 V D.C.
 24 V / 1~ / 50 Hz
 120 V / 1~ / 50 / 60 Hz
 208-240 V / 1~ / 50 / 60 Hz
 protection class: IP 55 (evaluation according to IEC 34)

The diagrams show the application range while operating with capacity control, remaining refrigerant capacity and power input at 25°C suction gas temperature.

Cooling capacity (part load) = cooling capacity (full load) x factor

Power input (part load) = power input (full load) x factor

Tentative Data

3.2.1 D3D Moduload R134a HM Part-load Factors

The diagrams show the application range while operating with capacity control, remaining refrigerant capacity and power input at 25°C suction gas temperature.

Diagram 1

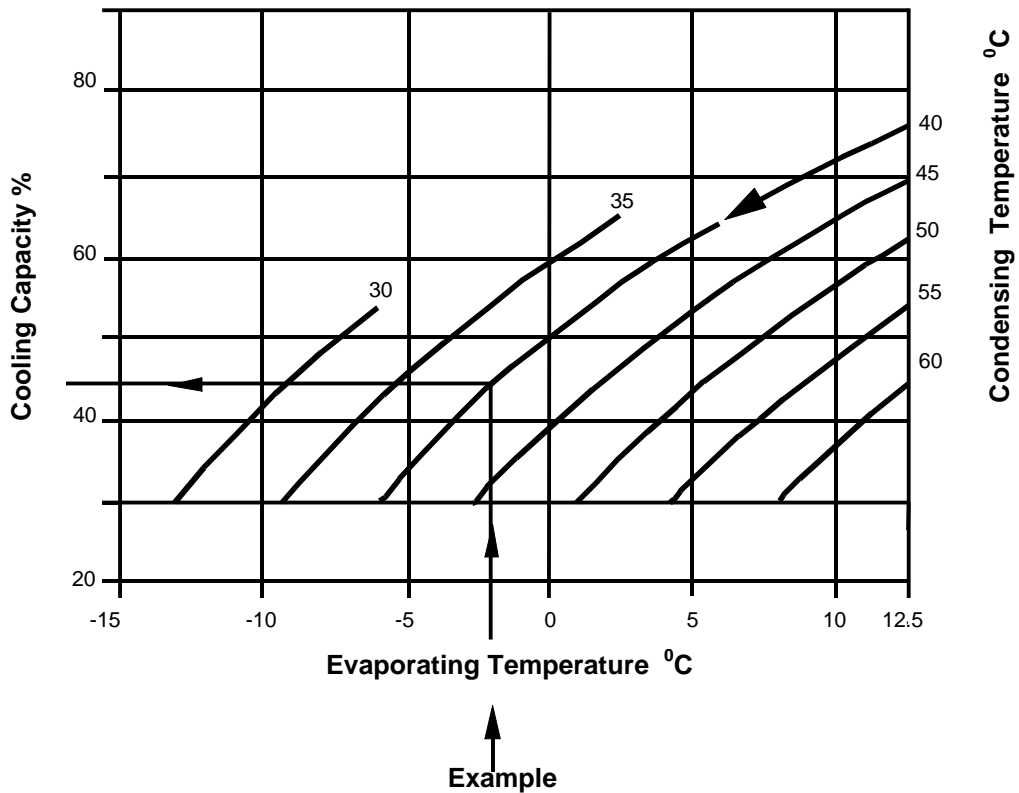
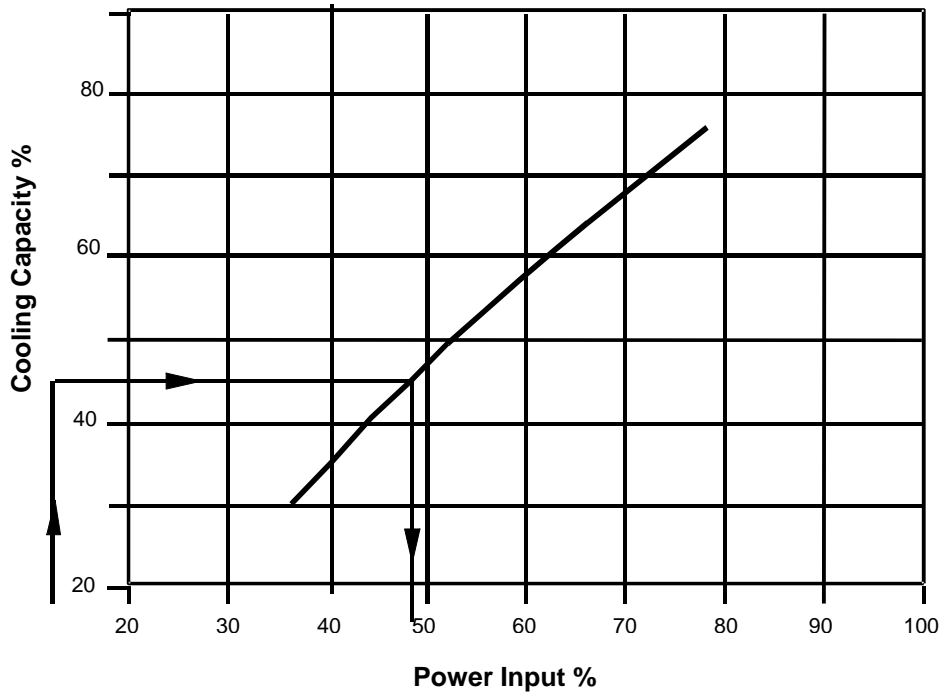

3.2.2 D3D Moduload R134a HH Part-load Factors

Diagram 2

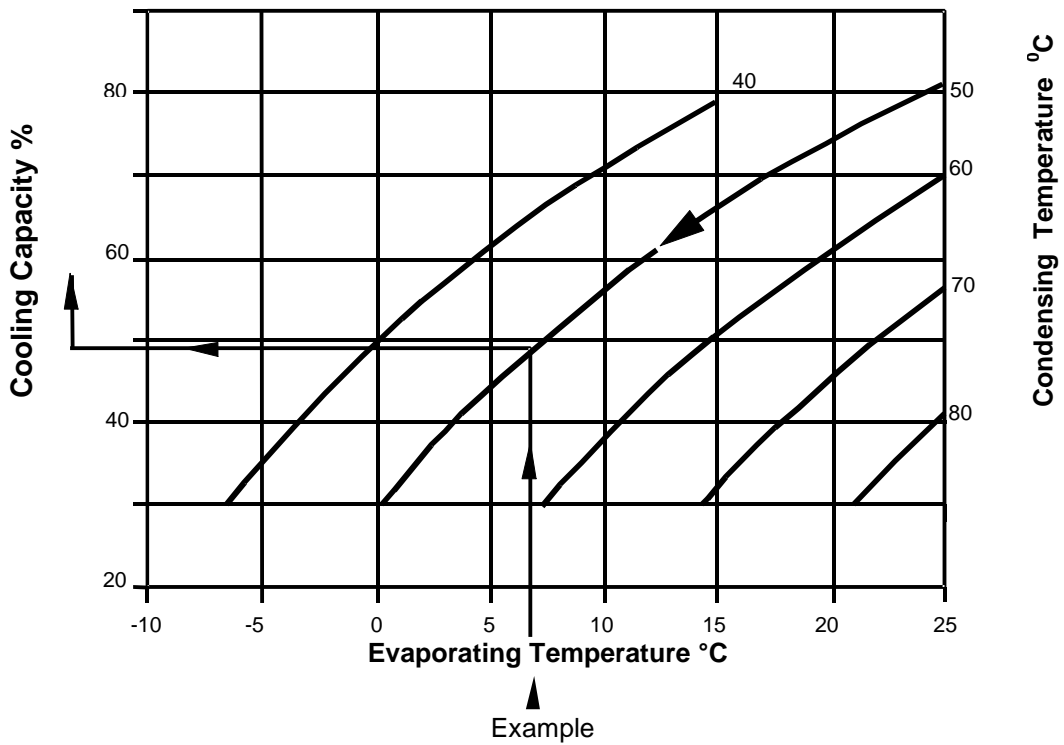
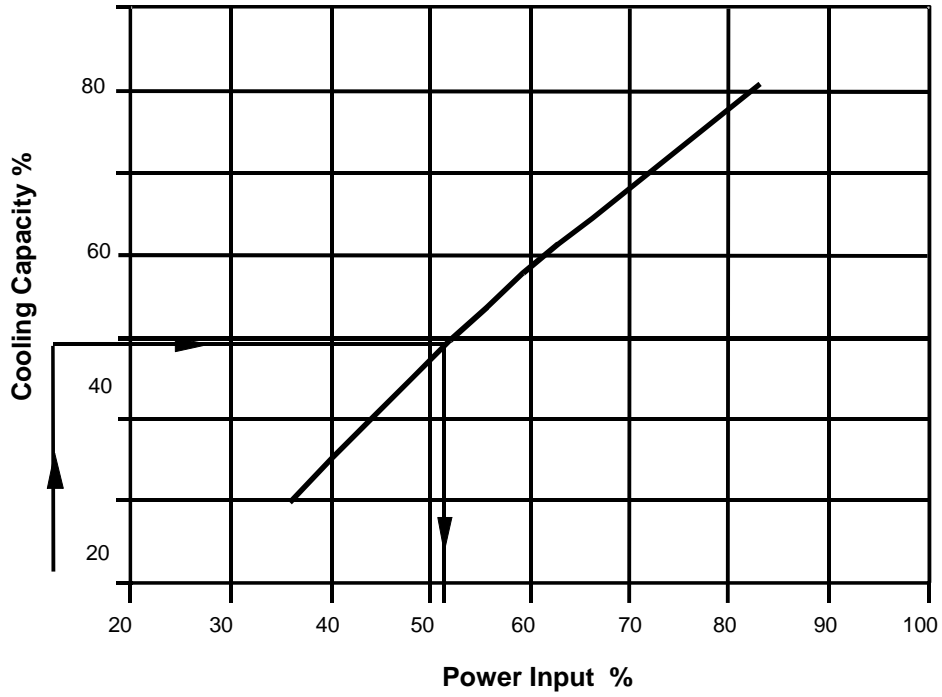

3.2.3 D3D Moduload R404A HM Part-load Factors

Diagram 3

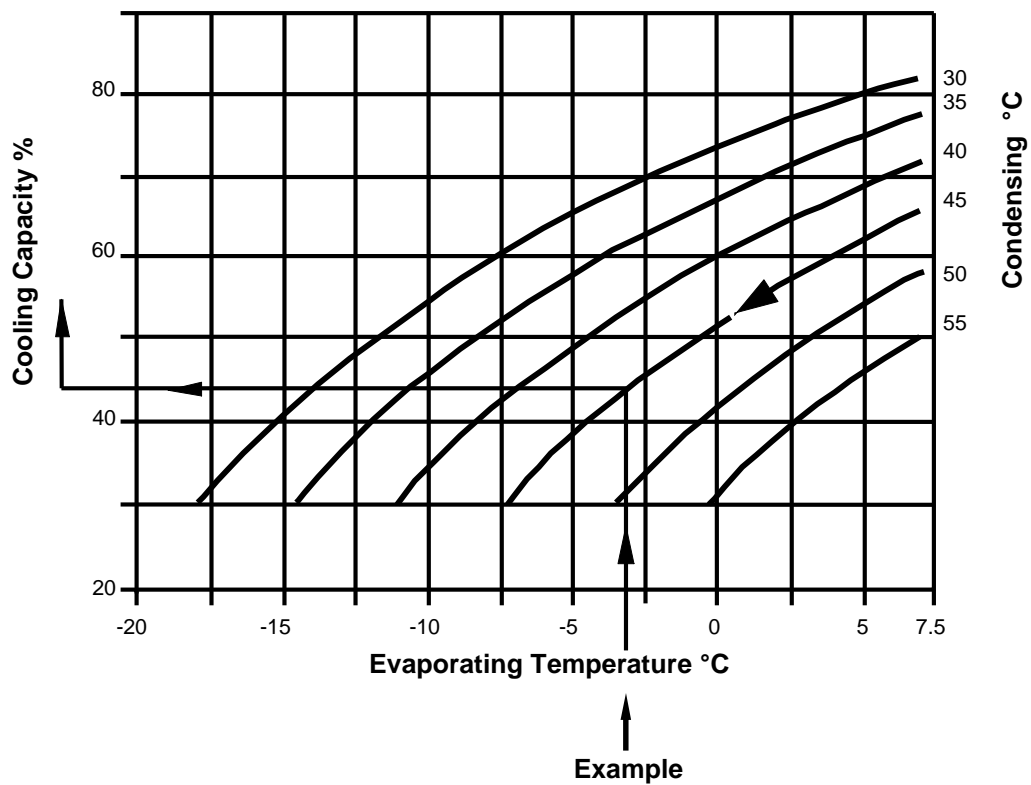
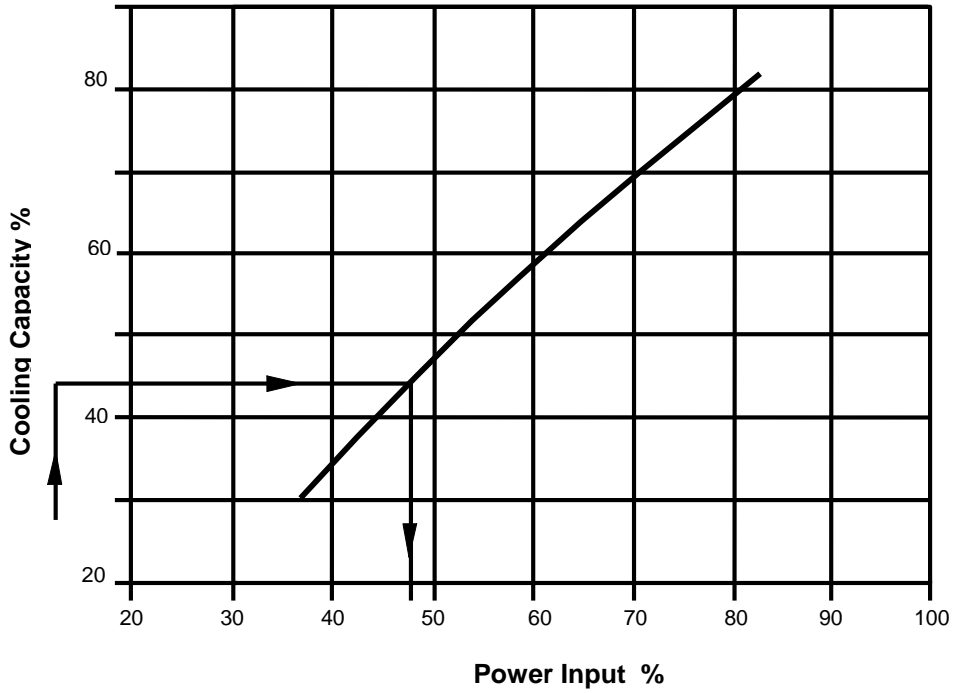

3.2.4 D3D Moduload R404A LXZ Part-load Factors

Diagram 4

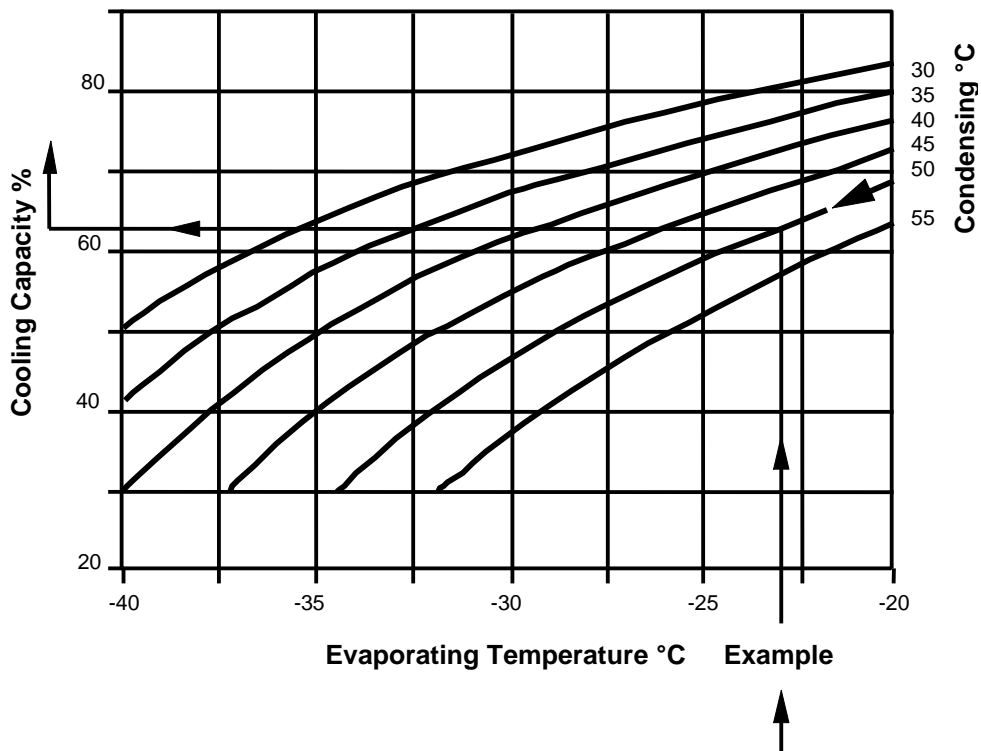
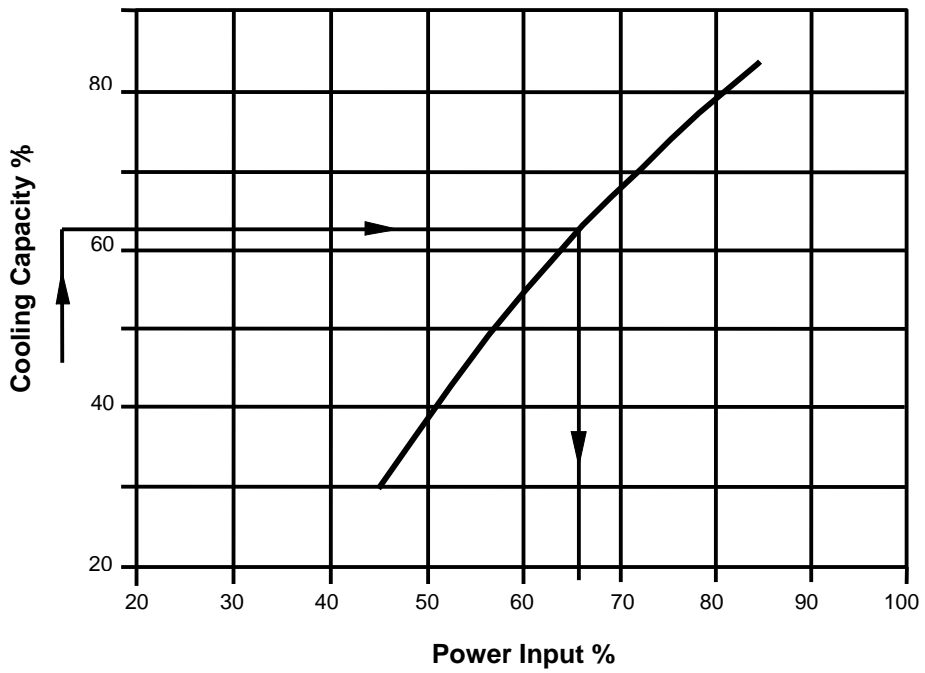

3.2.5 D3D Moduload R22 HM Part-load Factors

Diagram 5

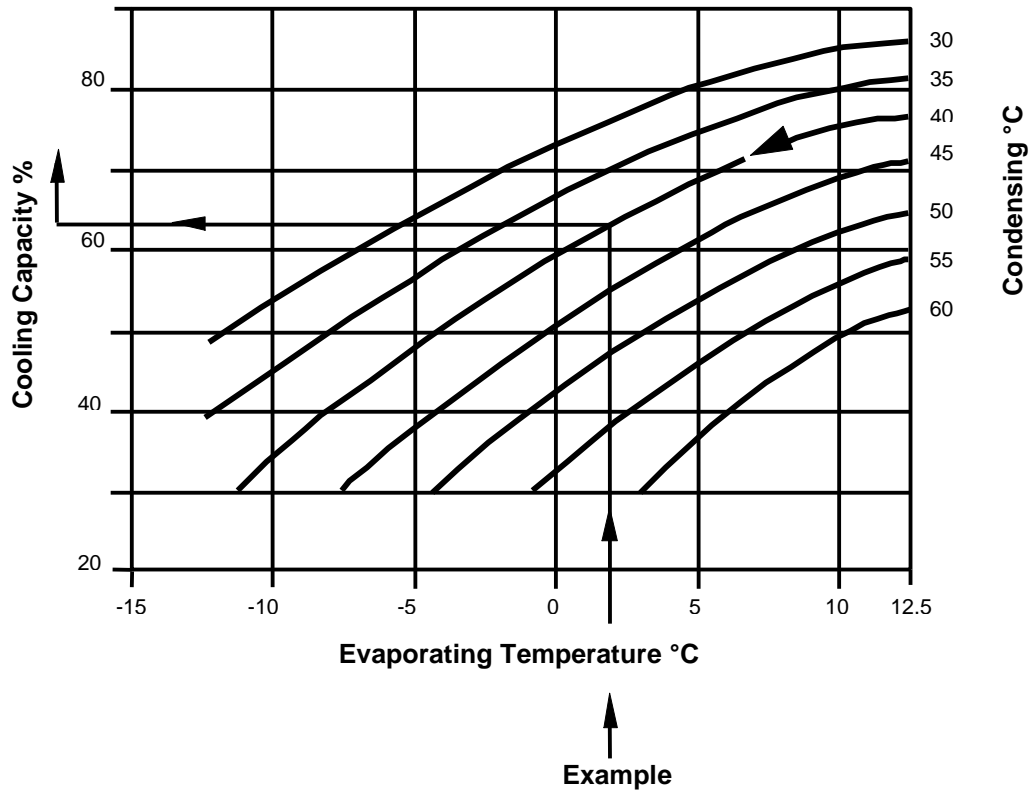
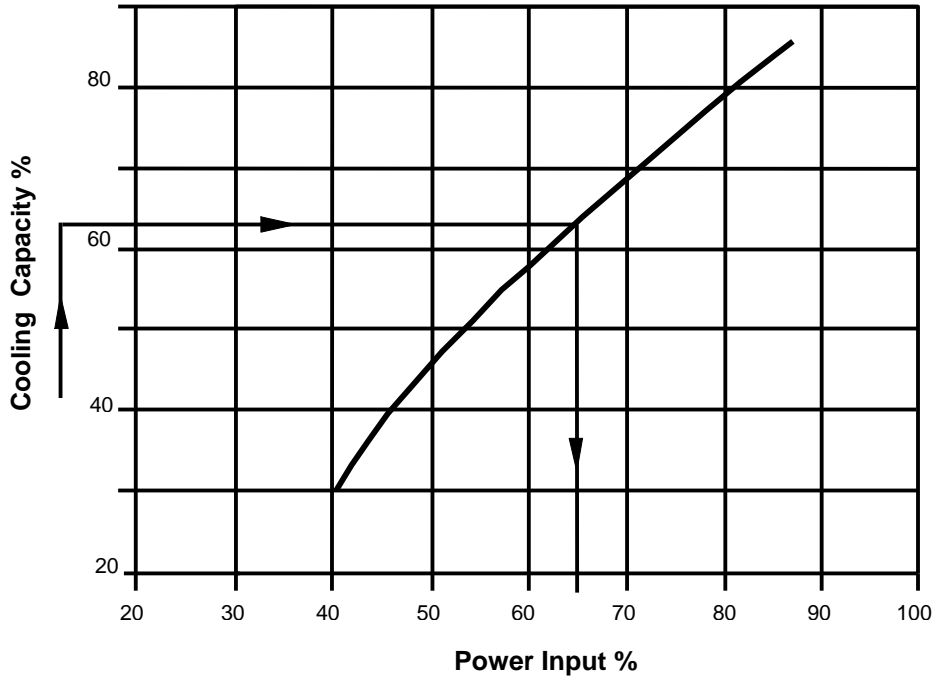

4 Capacity Control D4D, D6D and D8D Compressors

Capacity-controlled D4D, D6D, and D8D compressors work on the principle of blocking the suction gas passage to two or more cylinders. They require the use of a special cylinder head, a control valve with solenoid coil, and in the case of Discus a special valve plate, too. These items may be ordered installed at the factory or in kit form for later installation.

Normal Operation Full Load: When the solenoid coil is not energised the top of the control piston is vented to suction pressure allowing the piston to be lifted by means of a spring. The compressor draws gas from all cylinders and reaches full cooling capacity.

Capacity Controlled Operation (Part Load): When the solenoid coil is energised the top of the control piston is forced down by gas at discharge pressure blocking the suction gas passage into the cylinders thus enabling the compressor to run with a reduced capacity.

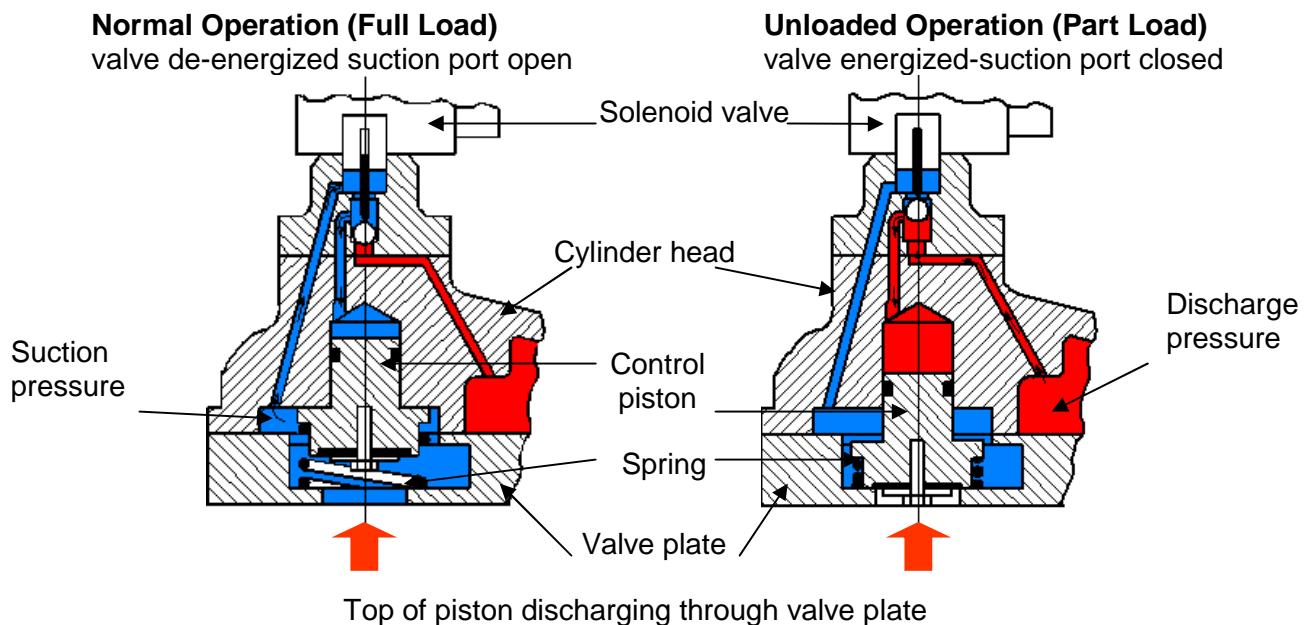

Voltages of the solenoid valve coil:
 24 V D.C.
 24 V / 1~ / 50 Hz
 120 V / 1~ / 50 / 60 Hz
 208-240 V / 1~ / 50 / 60 Hz
 protection class: IP 55 (evaluation according to IEC 34)

4.1 Capacity Controlled Cylinder Head Gaskets for 4, 6 & 8 Semi-Hermetic Compressors

All capacity control prepared cylinder heads on 4, 6 and 8 cylinder semi-hermetic compressors are delivered with the mounted inactive gasket for the capacity controlled port, this will ensure full capacity operation of the compressor if the solenoid control valve is not installed for any reason. To activate the capacity control, the blind flange and the inactive gasket have to be removed and to be replaced by the solenoid control valve and the active gasket which is provided with the conversion kit.

The gasket change was effective with compressors shipped from our Welkenraedt, Belgium plant from August 17, 1999

Conversion kit includes;

1 x cylinder head for capacity control "C"

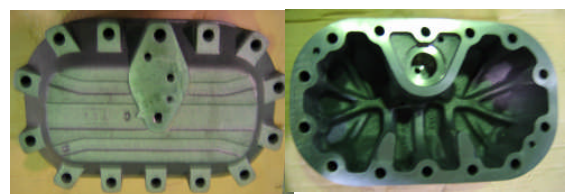

- 1 x valve plate and gasket kit
- 1 x solenoid valve assembly
- 2 x mounting screws

Capacity control must be fitted in the following positions:

- | | | |
|--------------------------|-----|---------------------------------------------|
| D4D | 50% | terminal box side |
| D6D 1 st step | 33% | terminal box side |
| D6D 2 nd step | 66% | upper cylinder head |
| D8D 1 st step | 25% | lower cylinder head on terminal box side |
| D8D 2 nd step | 50% | lower cylinder head on discharge valve side |

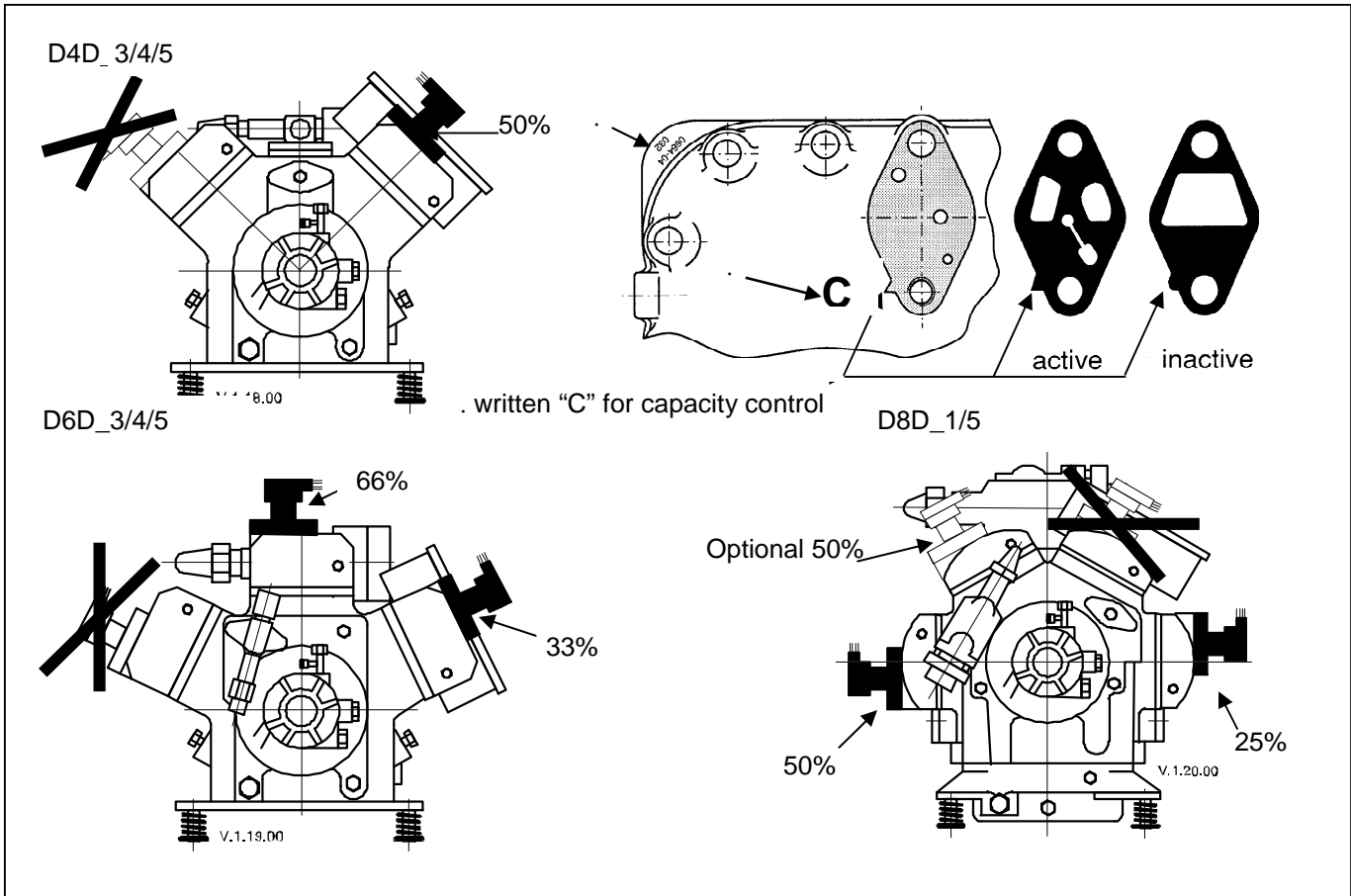
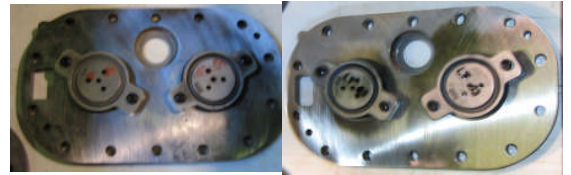

4.2 R134a Capacity Control Selection Table

D4D - D8D

Compressor	No.Cylinders with Cap.Con.	Capacity Regulating Step			Remaining Refrigeration Capacity / Power Input (average values) %								Diagram No	
		0	1	2	Application Range									
					HH	H	M	L	HH	H	M	L		
D4DA-100X	2	100%	50%			51	52				53	59		8
D4DH-150X	2	100%	50%			51	52				53	59		8
D4DA-200X	2	100%	50%		51					53				9
D4DJ-200X	2	100%	50%			51	52				53	59		8
D4DH-250X	2	100%	50%		51					53				9
D4DJ-300X	2	100%	50%		51					53				9
D6DH-200X	2 / 4	100%	66%	33%		67/34	68/34				68/36	70/41		8
D6DJ-300X	2 / 4	100%	66%	33%		67/34	68/34				68/36	70/41		8
D6DH-350X	2 / 4	100%	66%	33%	67/34					68/36				9
D6DJ-400X	2 / 4	100%	66%	33%	67/34					68/36				9
D8DH-500X	2 / 4	100%	75%	50%	75/51	75/51	75/52			77/53	77/53	78/59		8(HM) /10(HH)
D8DJ-600X	2 / 4	100%	75%	50%	75/51	75/51	75/52			77/53	77/53	78/59		8(HM) /10(HH)

Application limit see data sheets and application diagrams

- HH = heat pump
- H = high
- M = medium
- L = low temperature

Superheat 20 K

D4D - D8D

Compressor	Number of Cylinders with Capacity Control	Capacity Regulating Step			Remaining Refrigeration Capacity / Power Input (average values) %		Diagram No
		0	1	2	Application Range		
					H	H	
D4DA-2000	2	100%	50%		51	53	11
D4DH-2500	2	100%	50%		51	53	
D4DJ-3000	2	100%	50%		51	53	
D6DH-3500	2 / 4	100%	66%	33%	67/34	68/34	
D6DJ-4000	2 / 4	100%	66%	33%	67/34	68/34	
D8DH-5000	2 / 4	100%	75%	50%	76/52	80/58	12
D8DJ-6000	2 / 4	100%	75%	50%	76/52	79/57	

Application limit see data sheets and application diagrams

H = high

4.4 R22 Capacity Control Selection Table

4.5 R22 Application Range

4.5.1 D4D – D8D

Diagram 11 Suction gas temperature 25°C

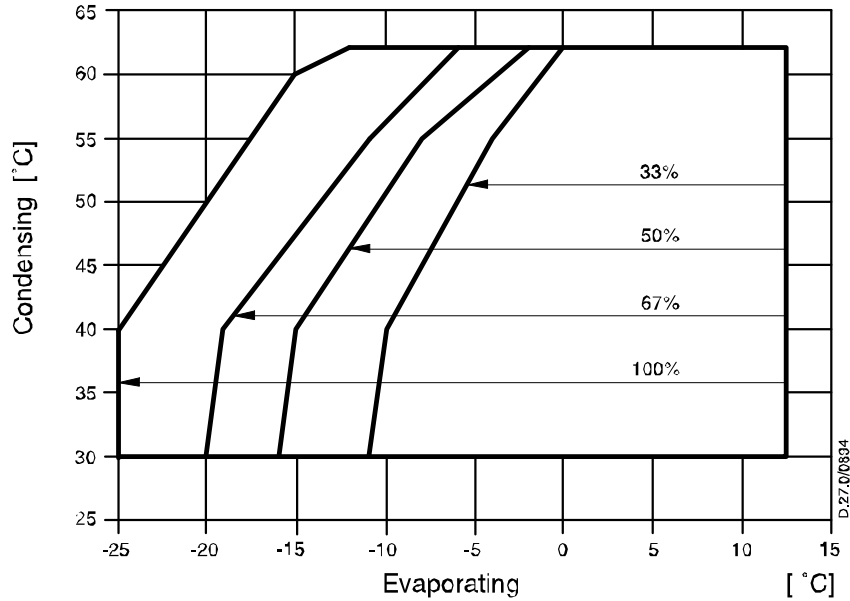
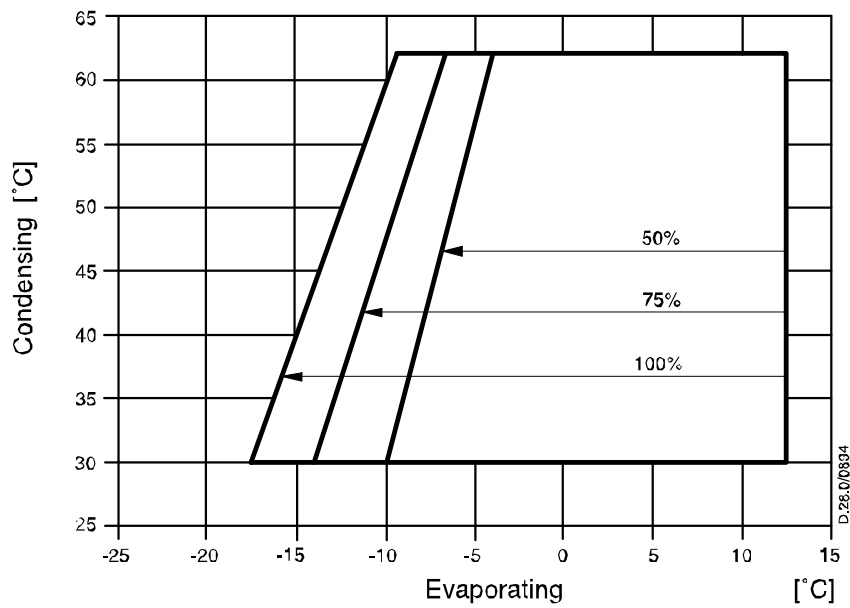

Diagram 12 Suction gas temperature 25°C



4.6 R404A Capacity Control Selection Table

D4D - D8D

Compressor	Number of Cylinders with Capacity Control	Capacity Regulating Steps			Remaining Refrigeration Capacity / Power Input								Diagram No
		0	1	2	Application Range								
					HH	H	M	L	HH	H	M	L	
D4DF-100X	2	100%	50%				52					59	13
D4DL-150X	2	100%	50%				52					59	13
D4DA-200X	2	100%	50%			51	52			53	59		15
D4DT-220X	2	100%	50%				52					59	13
D4DH-250X	2	100%	50%			51	52			53	59		15
D4DJ-300X	2	100%	50%			51	52			53	59		15
D6DL-270X	2	100%	66%				68					70	13
D6DT-300X	2	100%	66%				68					70	13
D6DH-350X	2 / 4	100%	66%	33%		67/34	68/34			68/36	70/41		16
D6DJ-400X	2 / 4	100%	66%	33%		67/34	68/34			68/36	70/41		16
D8DL-370X	2	100%	75%				77					78	14
D8DT-450X	2	100%	75%				77					78	14
D8DH-500X	2 / 4	100%	75%	50%		76/52	76/52			79/56	80/58		17
D8DJ-600X	2 / 4	100%	75%	50%		76/53	76/53			79/56	80/58		17

Application limit see data sheets and application diagrams

- HH = heat pump
- H = high
- M = medium
- L = low temperature

4.7 R404A Application Range

4.7.1 D4D – D8D

Diagram 13

Suction gas temperature 25°C

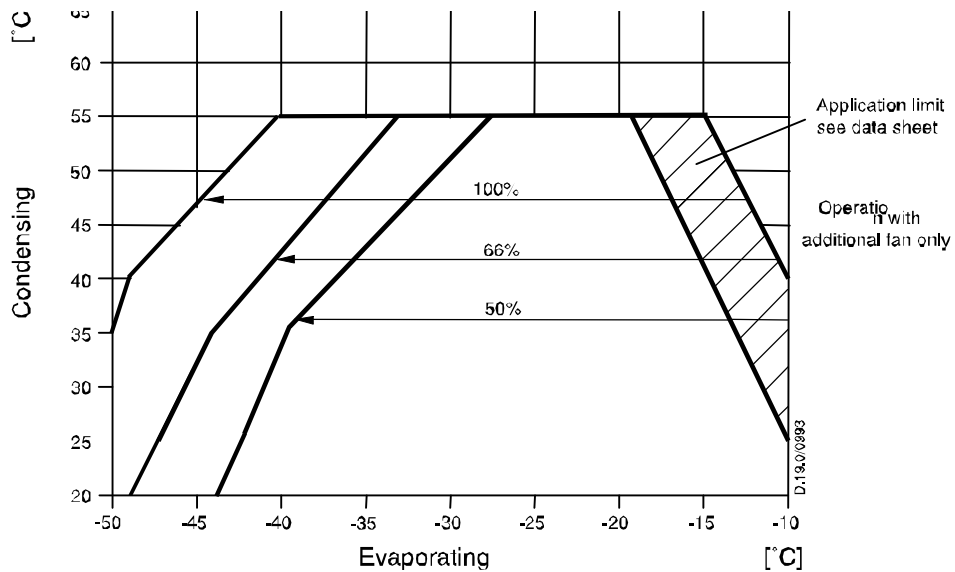

Diagram 14
Suction gas temperature 25°C

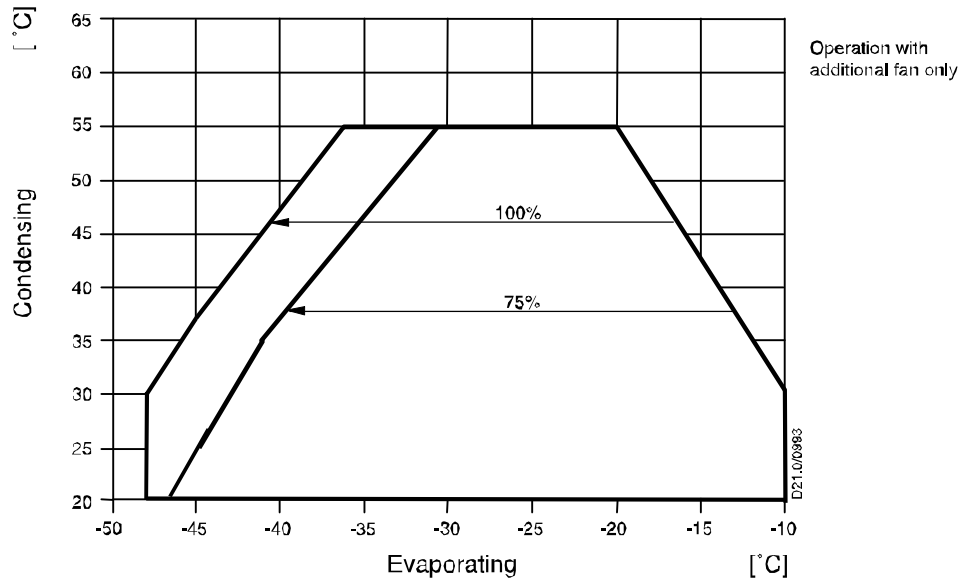

Diagram 15
Suction gas temperature 25°C

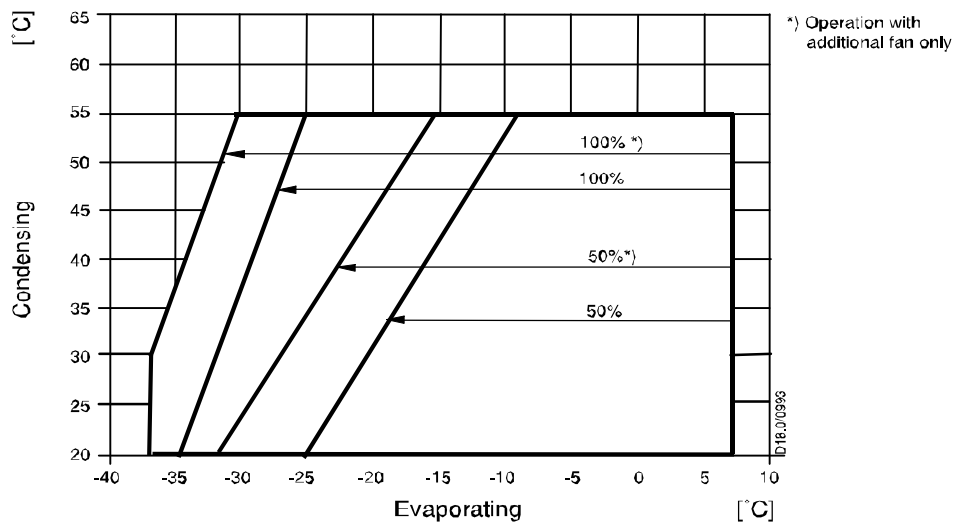

Diagram 16 Suction gas temperature 25°C Reduction to 33% with standard additional Ventilation not possible due to lack of space

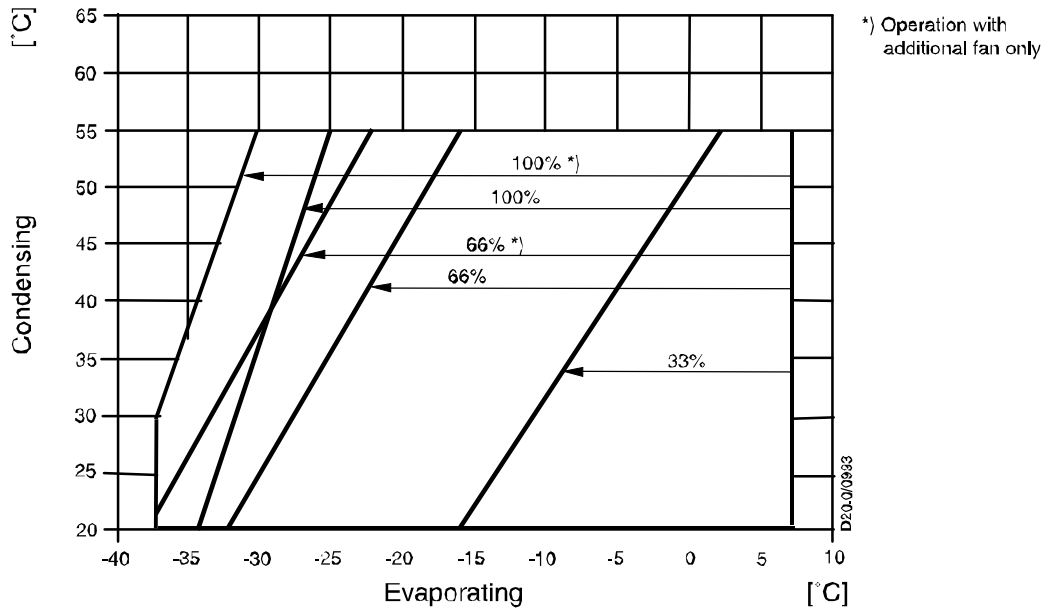
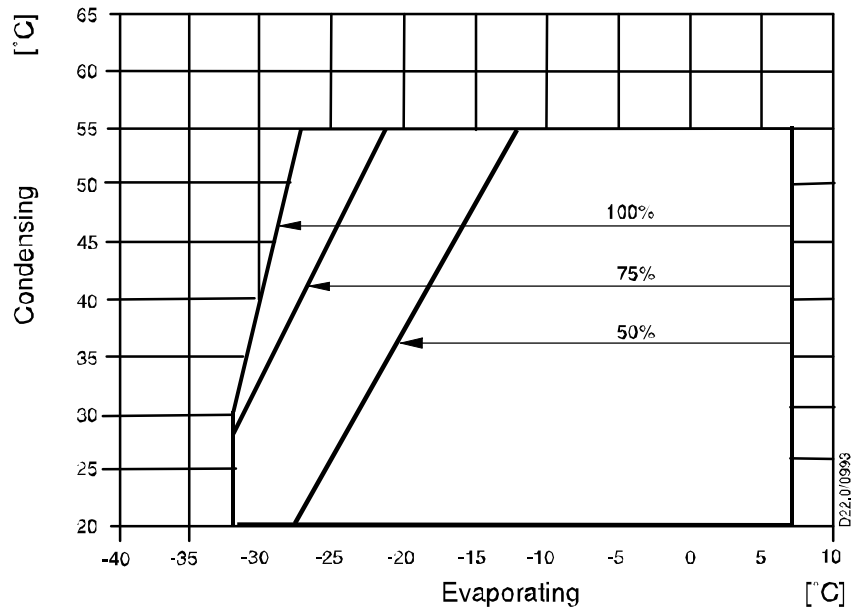

Diagram 17 Suction gas temperature 25°C



4.8 R407C (mid-point) Capacity Control Selection Table

D4D - D8D

Compressor	Number of Cylinders with Capacity Control	Capacity Regulating Step			Remaining Refrigeration Capacity / Power Input (average values) %		Diagram No
		0	1	2	Application Range		
					H	H	18
D4DA-200X	2	100%	50%		51	53	
D4DH-250X	2	100%	50%		51	53	
D4DJ-300X	2	100%	50%		51	53	
D6DH-350X	2 / 4	100%	66%	33%	67/34	68/34	
D6DJ-400X	2 / 4	100%	66%	33%	67/34	68/34	
D8DH-500X	2 / 4	100%	75%	50%	76/52	80/58	19
D8DJ-600X	2 / 4	100%	75%	50%	76/53	79/57	

Application limit see data sheets and application diagrams

H = high

4.9 R407C (mid-point) Application Range

4.9.1 D4D – D6D

Diagram 18 Suction gas temperature 25° C

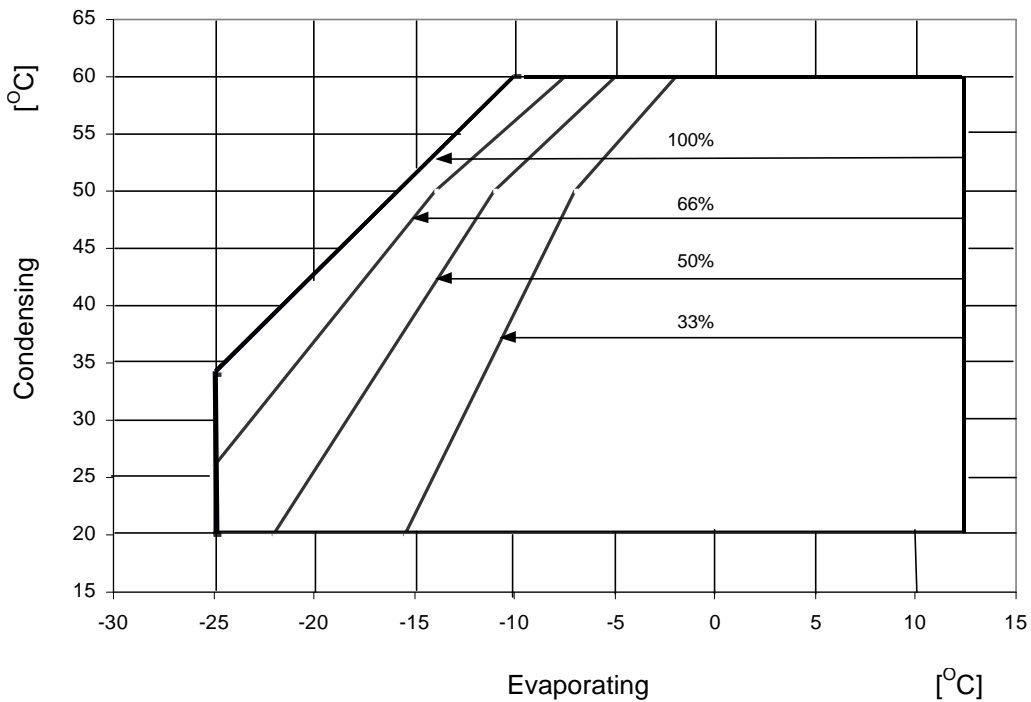

4.9.2 D8D

Diagram 19 Suction gas temperature 25° C

