

Application guidelines

Danfoss scroll compressors **CH290 & CH485**

50 Hz - R410A



Scroll compression principle	4	System design recommendations	22
Features	5	General	22
Compressor model designation	6	Essential piping design recommendations.....	22
Nomenclature.....	6	Refrigerant charge limit	23
Technical specifications	7	Off-cycle migration.....	24
50 Hz data	7	Liquid flood back.....	26
Dimensions	8	Specific application recommendations	27
CH290	8	Low ambient application.....	27
CH290 - Parallel version.....	9	Low load operation.....	28
CH485	10	Brazed plate heat exchangers.....	28
Suction and discharge Connections.....	11	Electronic expansion valve	28
Electrical data, connections and wiring.....	12	Reversible heat pump systems.....	28
Connection details	12	Sound and vibration management	31
Motor voltage	12	Starting sound level.....	31
Wiring connections.....	13	Running sound level	31
IP rating.....	13	Stopping sound level	31
Terminal box temperature	13	Installation	33
Three phase electrical characteristics	14	Compressor handling and storage.....	33
LRA (Locked Rotor Amp).....	14	Compressor mounting	34
MCC (Maximum Continuous Current).....	14	Compressor holding charge.....	34
Max. Operating Current.	14	System cleanliness	35
Winding resistance.....	14	Tubing.....	35
General wiring information	14	Brazing and soldering.....	35
Danfoss MCI soft-start controller.....	15	System pressure test	36
Motor protection	17	Leak detection	37
Voltage imbalance	17	Vacuum evacuation and moisture removal.....	37
Operating conditions	18	Filter driers	37
Refrigerant and lubricants.....	18	Refrigerant charging	37
Motor supply.....	19	Insulation resistance and dielectric strength.....	38
Compressor ambient temperature	19	Commissioning	38
Application envelope.....	19	Oil level checking and top-up.....	38
Discharge temperature protection	20	Ordering information and packaging.....	39
High and low pressure protection.....	20	Accessories	40
Cycle rate limit	21		

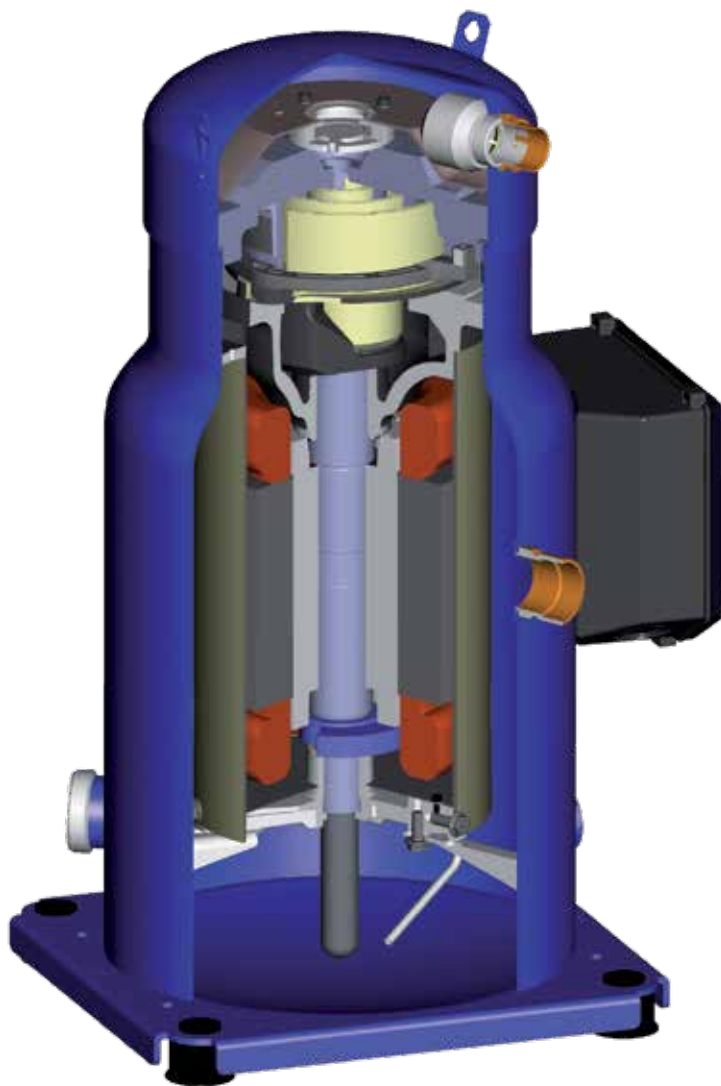

In a Danfoss CH scroll compressor, the compression is performed by two scroll elements located in the upper part of the compressor.

Suction gas enters the compressor at the suction connection. As all of the gas flows around and through the electrical motor, thus ensuring complete motor cooling in all applications, oil droplets separate and fall into the oil sump. After exiting the electrical motor, the gas enters the scroll elements where compression takes place. Ultimately, the discharge gas leaves the compressor at the discharge connection.

The figure below illustrates the entire compression process. The centre of the orbiting scroll (in grey) traces a circular path around the centre of the fixed scroll (in black). This movement creates symmetrical compression pockets between the two scroll elements. Low-pressure suction gas is trapped within each crescent-shaped pocket as it gets formed; continuous motion of the orbiting scroll serves to seal the pocket, which decreases in volume as the pocket moves towards the center of the scroll set increasing the gas pressure. Maximum compression is achieved once a pocket reaches the center where the discharge port is located; this stage occurs after three complete orbits. Compression is a continuous process: the scroll movement is suction, compression and discharge all at the same time.

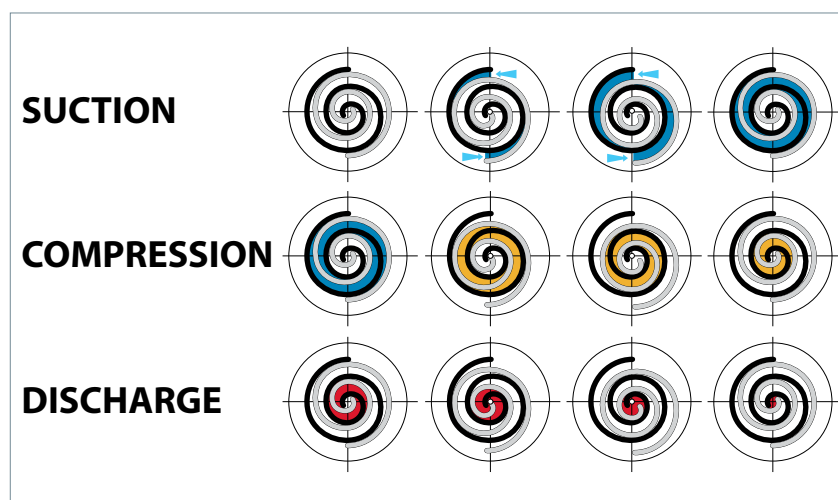

CH range is composed of CH290 & CH485 (large commercial platform).

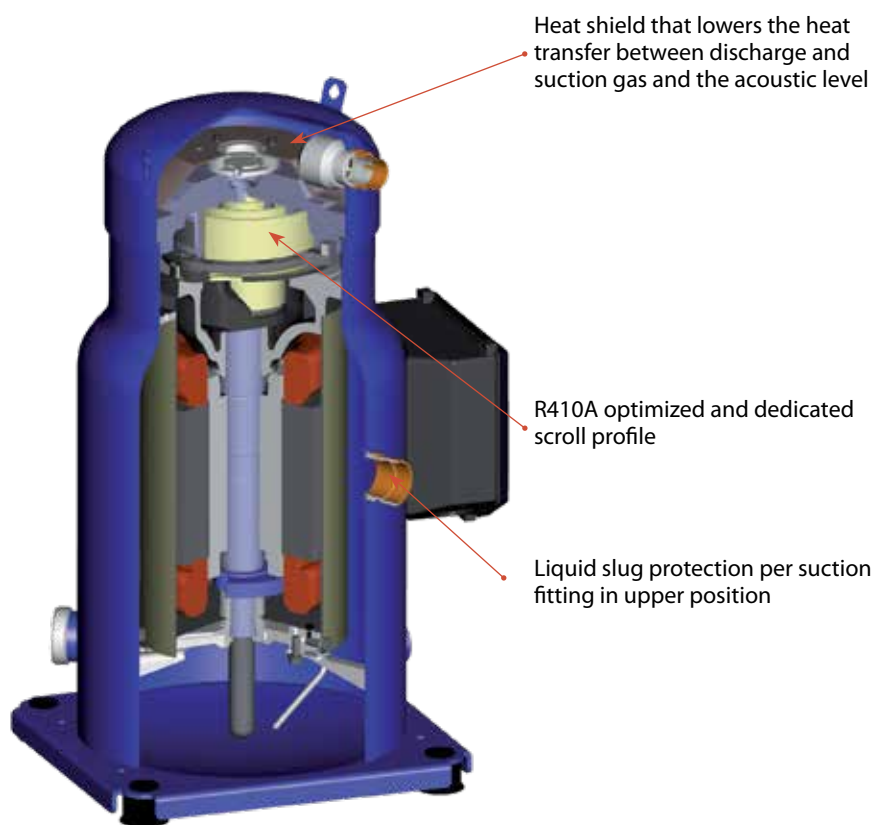

Danfoss CH290 & CH485 scroll compressor for R410A are available as single compressor. The example below presents the compressor nomenclature which equals the technical

reference as shown on the compressor nameplate. Code numbers for ordering are listed section "Ordering information and packaging".

Nomenclature

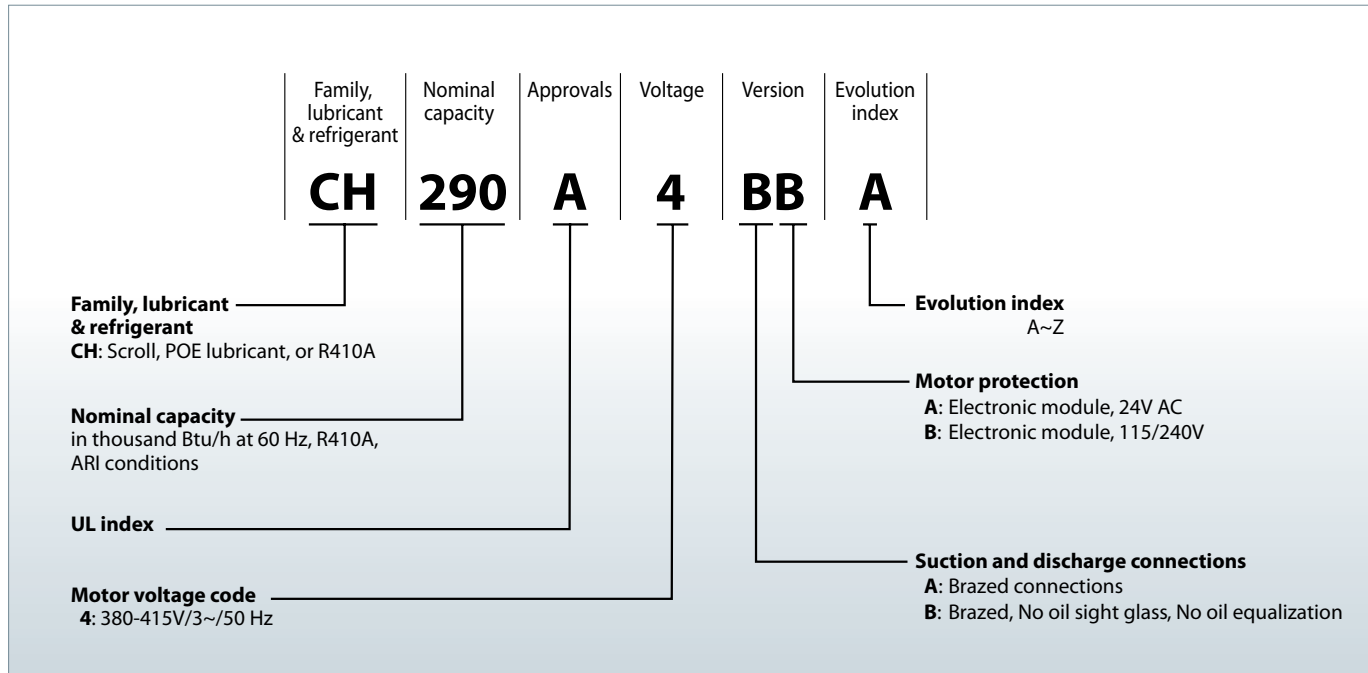

50 Hz data

Model (50 Hz)	Nominal tons 60 Hz	Nominal cooling capacity		Power input	COP	E.E.R.	Swept volume	Displacement ①	Oil charge	Net weight ②
	TR	W	Btu/h	kW	W/W	Btu/h/W	cm ³ /rev	m ³ /h	dm ³	kg
CH290	25	73 200	249 800	22.50	3.25	11.10	276.2	48.10	6.7	111.0
CH485	40	116 400	397 300	35.65	3.26	11.13	442.60	77.0	6.7	175.0

① Displacement at nominal speed: 2900 rpm at 50 Hz

② Net weight with oil charge

TR: Ton of Refrigeration,
EER: Energy Efficiency Ratio
COP: Coefficient Of Performance,

Standard rating conditions: ARI standard
Refrigerant: R410A

Evaporating temperature: 7.2 °C
Condensing temperature: 54.4 °C

Superheat: 11.1 K
Subcooling: 8.3 K

Subject to modification without prior notification.

CH290

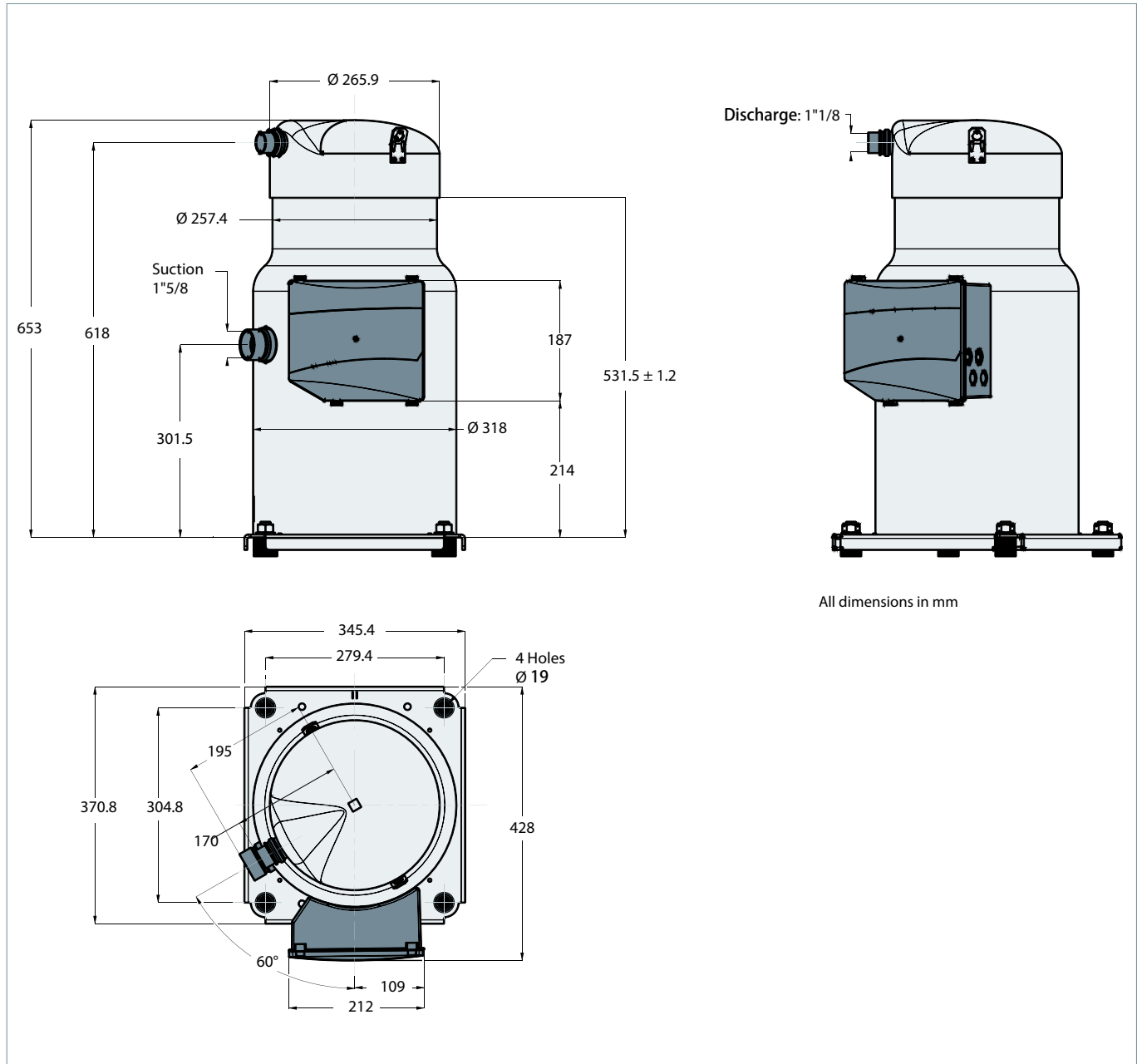

Flexible grommet

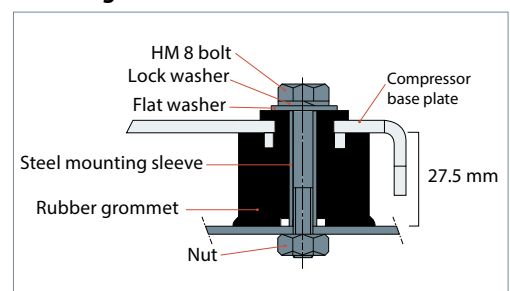

CH290 - Parallel version

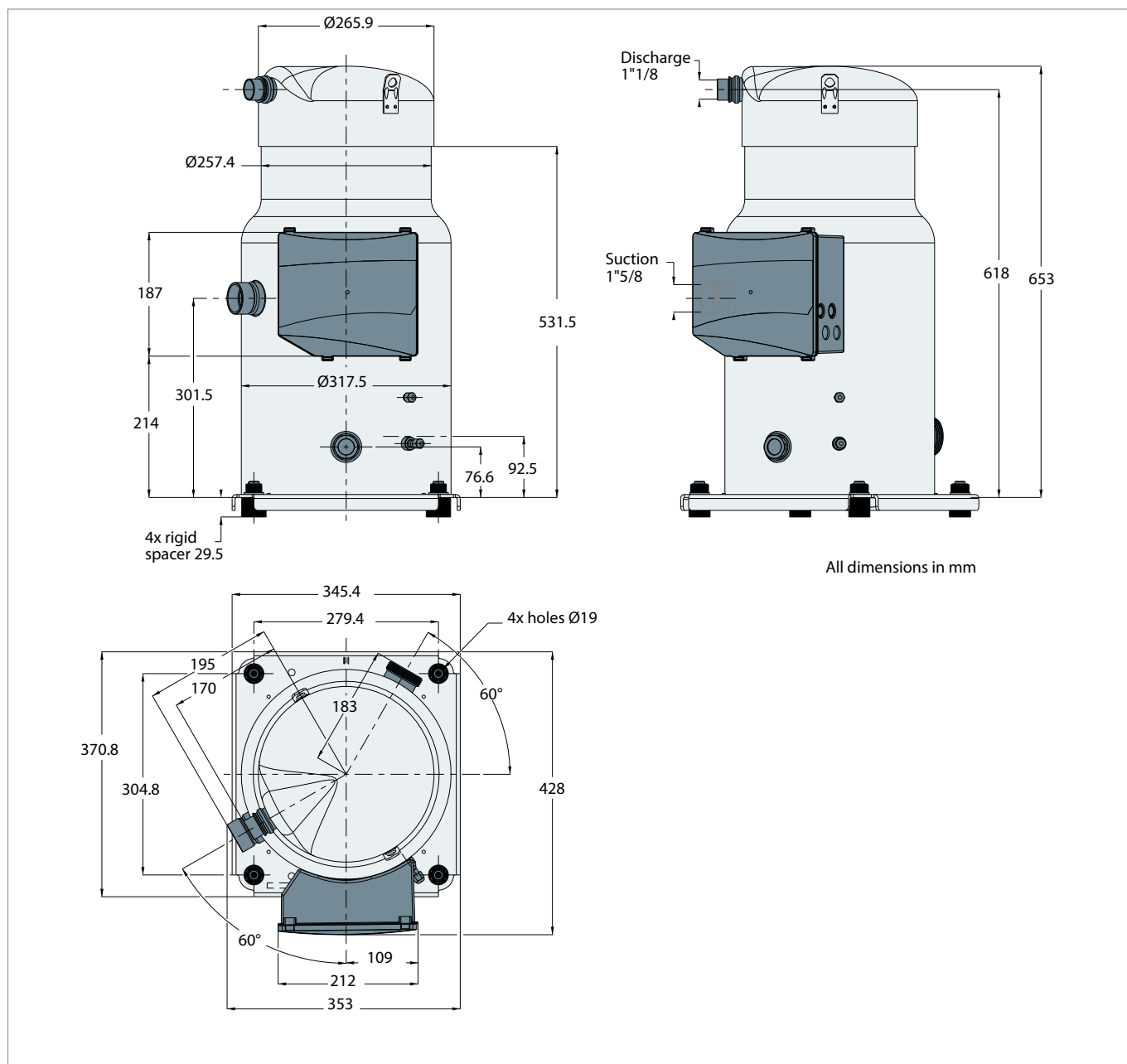

Rigid spacer

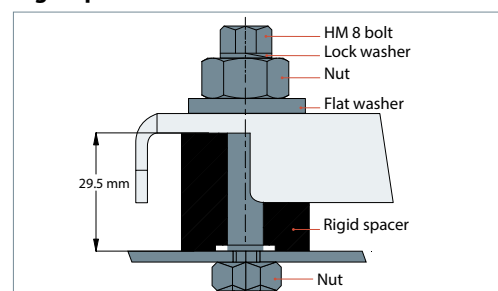

CH485

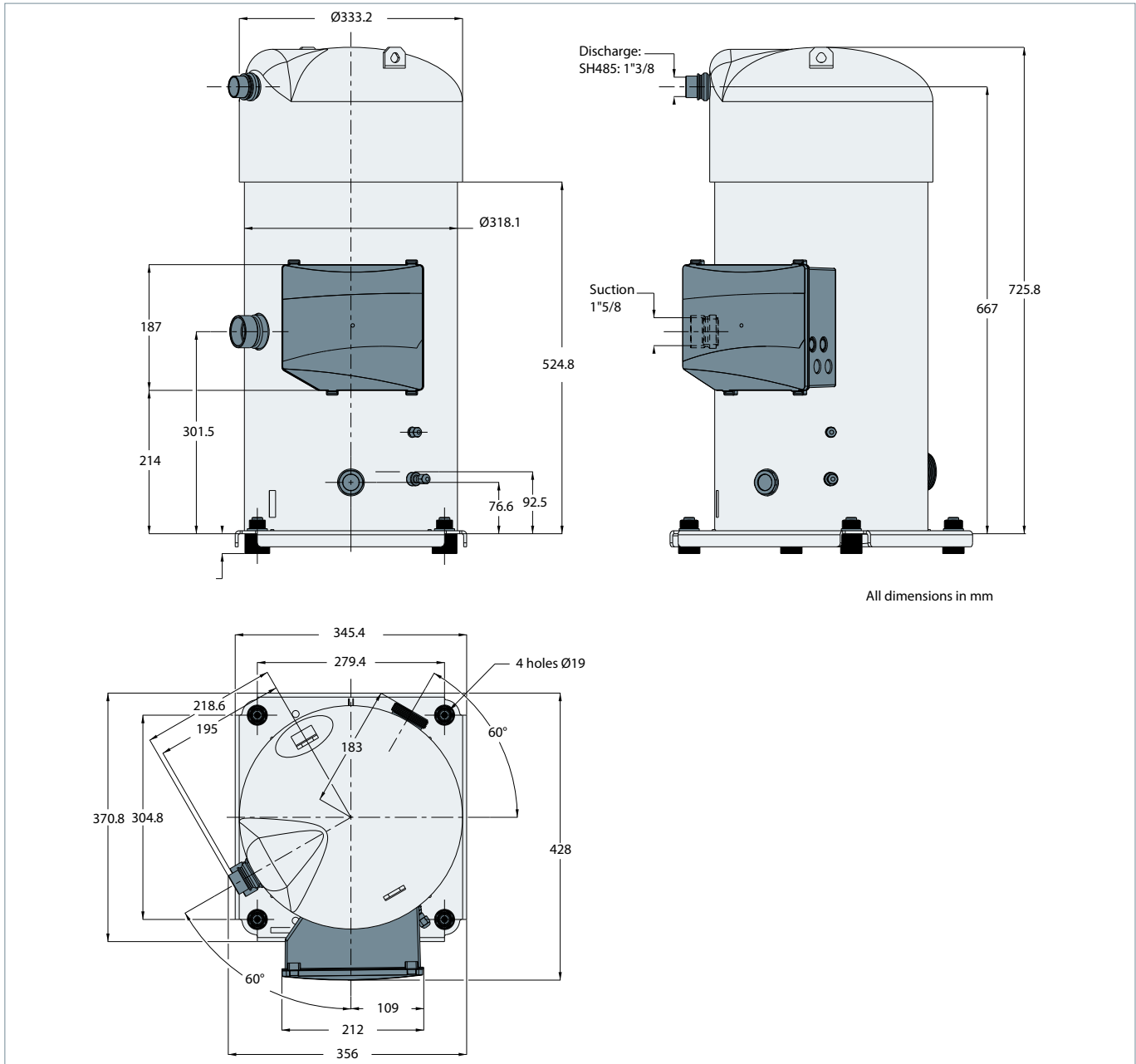

Rigid spacer

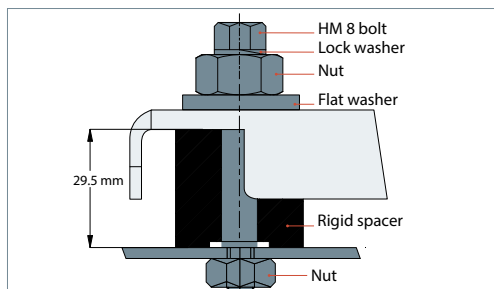

Flexible grommet

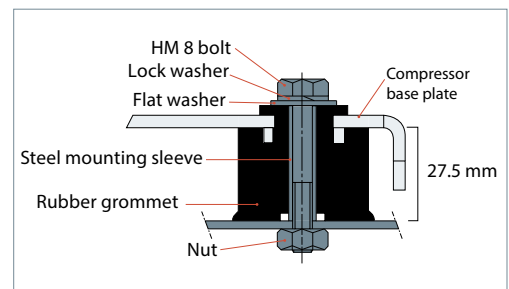

Suction and discharge Connections

Brazed version



Tube ODF

Brazed

CH290	Suction	1"5/8
	Discharge	1"1/8
CH485	Suction	1"5/8
	Discharge	1"3/8

**Connection details
(Versions dedicated for
parallel mounting only)**

		CH290 & 485
Version		AA - AB
Suction and discharge connections		Brazed
Oil sight glass		Threaded
Oil equalisation connection		rotolock 2"1/4
Oil drain connection		1/4" flare
Low pressure gauge port (schrader)		1/4" flare

Motor voltage

Danfoss CH290-485 scroll compressors are available with the motor voltage code 4:

Motor voltage code		Code 4
50 Hz	Nominal voltage	380-415V - 3ph
	Voltage range	342-457V

Wiring connections

Electrical power is connected to the compressor terminals by Ø 4.8 mm (3/16") screws.

The maximum tightening torque is 3 Nm. Use a 1/4" ring terminal on the power leads.

The terminal box is provided with 2 triple knockouts and 1 single knockout for power supply and 4 double knockouts for the safety control circuit.

The 3 power supply knockouts accommodate the following diameters:

- Ø 50.8 mm (UL 1"1/2 conduit) and Ø 43.7 mm (UL 1"1/4 conduit) and Ø 34.5 mm (UL 1" conduit)
- Ø 40.5 mm (ISO40) and Ø 32.2 mm (ISO32) and Ø 25.5 mm (ISO25)
- Ø 25.5 mm (ISO25)

The 4 others knockouts are as follows:

- Ø 22.5 mm (PG16) (UL 1/2") and Ø 16.5 mm (ISO16) (x2)
- 20.7 mm (ISO20 or PG13.5) (x2)

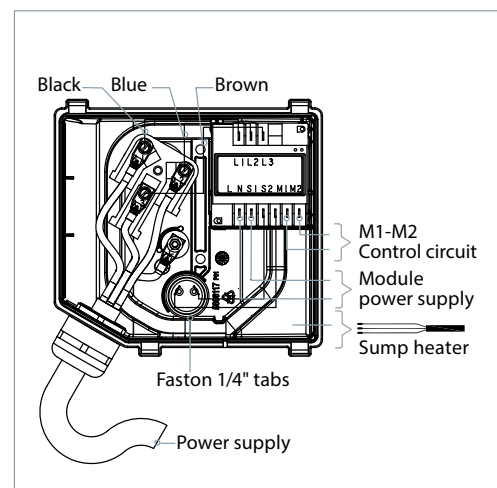

The motor protection module comes preinstalled within the terminal box. Phase sequence protection connections and thermistor connections are pre-wired and should not be deinstalled. The module must be connected to a power supply of the appropriate voltage. The module terminals are 6.3-mm size Faston type.

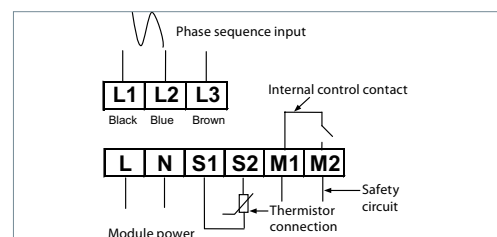

IP rating

The compressor terminal box according to IEC529 is IP54 when correctly sized IP54 rated cable glands are used.

First numeral, level of protection against contact and foreign objects

5 - Dust protected

Second numeral, level of protection against water

4 - Protection against water splashing

Terminal box temperature

The temperature inside the terminal box may not exceed 70°C. Consequently, if the compressor is installed in an enclosure, precautions must be taken to avoid that the temperature around the compressor and in the terminal box would rise too much. The installation of ventilation on the enclosure panels may be necessary. If not, the

electronic protection module may not operate properly. Any compressor damage related to this will not be covered by Danfoss warranty. In the same manner, cables must be selected in a way to insure that terminal box temperature does not exceed 70°C.

Three phase electrical characteristics

Compressor model		LRA	MCC	Max. operating current	Winding resistance
		A	A	A	Ω
Motor voltage code 4	CH290	260	62	56	0.52
	CH485	413	90	89	0.23

LRA (Locked Rotor Amp)

Locked Rotor Amp value is the higher average current as measured on mechanically blocked compressor tested under nominal voltage. The LRA value can be used as rough estimation for

the starting current. However in most cases, the real starting current will be lower. A soft starter can be applied to reduce starting current.

MCC (Maximum Continuous Current)

The MCC is the current at which the motor protection trips under maximum load and low voltage conditions. This MCC value is the maximum at which the compressor can be operated in transient conditions and out of

the application envelope. Above this value, the internal motor protection or external electronic module will cut-out the compressor to protect the motor.

Max. Operating Current.

The max. operating current is the current when the compressors operate at maximum load conditions and 10% below nominal voltage (+15°C evaporating temperature and +68°C

condensing temperature). Max Oper. A can be used to select cables and contactors. In normal operation, the compressor current consumption is always less than the Max Oper. A. value.

Winding resistance

Winding resistance is the resistance between phases at 25°C (resistance value +/- 7%). Winding resistance is generally low and it requires adapted tools for precise measurement. Use a digital ohm-meter, a "4 wires" method and measure under stabilised ambient temperature. Winding resistance varies strongly with winding temperature. If the compressor is stabilised at a different value than 25°C, the measured resistance must be corrected using following formula:

$$R_{tamb} = R_{25°C} \frac{a + t_{amb}}{a + t_{25°C}}$$

$t_{25°C}$: reference temperature = 25°C
 t_{amb} : temperature during measurement (°C)
 $R_{25°C}$: winding resistance at 25°C
 R_{amb} : winding resistance at t_{amb}
 Coefficient $a = 234.5$

General wiring information

The wiring diagrams below are examples for a safe and reliable compressor wiring. In case an alternative wiring logic is chosen, it is imperative to respect the following rules:

allow the system to build pressure. But it remains mandatory for compressor protection to apply an LP safety switch. The LP safety switch must never be bypassed.

When a safety switch trips, the compressor must stop immediately and must not re-start until the tripping condition is back to normal and the safety switch is closed again. This applies to the LP safety switch, the HP safety switch, the discharge gas thermostat and the motor safety thermostat.

Pressure settings for the LP and HP safety switch and pump-down listed in table from section "Low pressure".

In specific situations, such as winter start operation, an eventual LP control for pump-down cycles may be temporarily bypassed to

When ever possible (ie. PLC control), it is recommended to limit the possibilities of compressor auto restart to less than 3 to 5 times during a period of 12 hours when caused by motor protection or LP safety switch tripping. This control must be managed as a manual reset device.

Danfoss MCI soft-start controller

The inrush current for the CH scroll compressors with motor 380-415V / 3ph / 50Hz can be reduced using the Danfoss digitally-controlled MCI compressor soft starter. MCI & MCD soft starters are designed to reduce the starting current of 3-phase AC motors; they can reduce the inrush current by up to 40%, thereby eliminating the detrimental effects of high starting torque surges and costly demand charges from the resultant current spike. Upon starting, the controller gradually increases the voltage supplied to the motor until full-line voltage has been reached. All settings, such as ramp-up time (less than 0.5 sec) and initial torque, are preset and do not require modification.

When the control voltage is applied, the MCI50CM soft starter will start the motor, according to the settings of the ramp-up time and initial torque adjustments. When the control voltage is switched OFF, the motor will switch off instantaneously.

On CH compressors, by pass contactor K1 is required by means of the built-in auxiliary contact (23-24) the by-pass function is easily achieved, see wiring diagram beside.

No heat is generated from the MCI. As the contactor always switches in no-load condition it can be selected on the basis of the thermal current (AC-1).

Compressor model	Soft start reference Ambient max. 40°C	Soft start reference Ambient max. 55°C
CH290	MCI50CM *	MCI50CM *
CH485	MCD201-055	MCD201-055

* by-pass contactor K1 is required

Upon starting, the controller gradually increases the voltage supplied to the motor until full-line voltage has been reached.

For MCI50M, all settings such as initial torque, ramp-up time (less than 0.5 sec) and ramp-down time are preset and do not require any modification.

For MCD201-055, the following settings have to be adjusted to ensure a maximum inrush current reduction as well as a starting time less than 0.5 sec.

Frequency	Initial torque (%U)	Ramp-up (seconds)	Ramp down (seconds)
50 Hz	60%	2	0

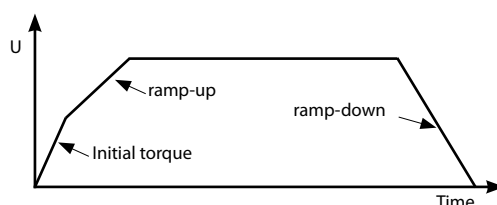
Input controlled soft start

When the control voltage is applied to A1 - A2, the MCI soft starter will start the motor, according to the settings of the ramp-up time and initial torque adjustments. When the control voltage is switched OFF, the motor will switch off instantaneously.

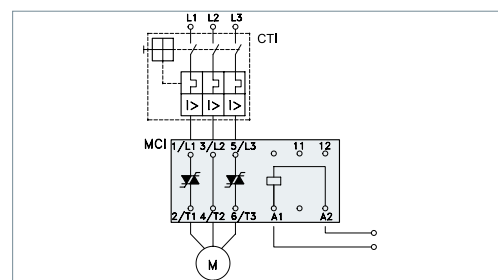
MCI with by-pass contactor

By means of the built-in auxiliary contact (23-24) the by-pass function is easily achieved, see wiring diagram beside.

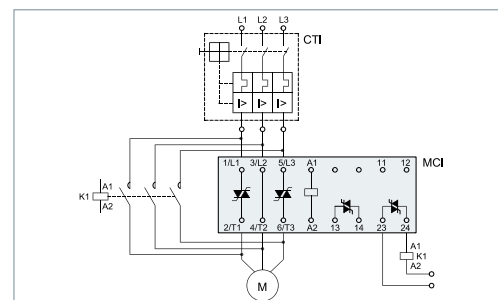

Suggested wiring diagrams logic

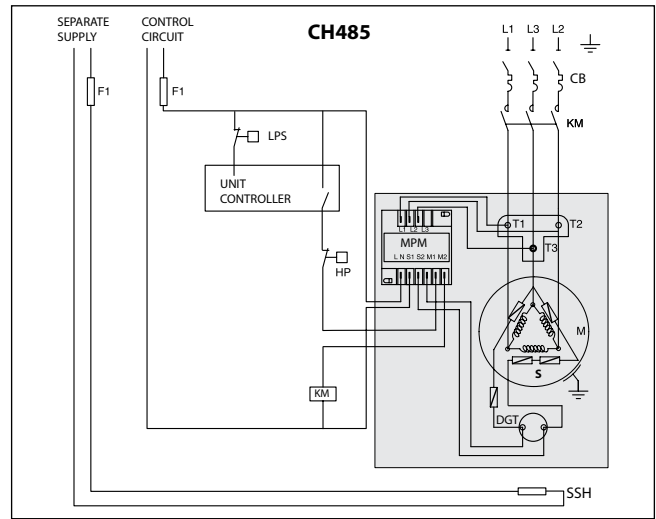
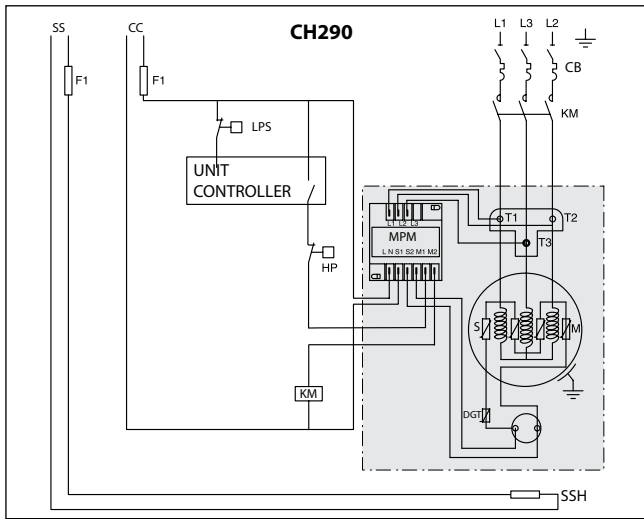

Legend

Fuses F1
 Compressor contactor KM
 High pressure safety switch HP
 Discharge gas thermistor (embedded in CH485) DGT
 Surface sump heater SSH

Compressor motor M
 Motor Protection Module MPM
 Thermistor chain S
 Safety pressure switch LPS
 Thermal magnetic circuit breaker CB

Motor protection

CH Compressor models are delivered with a pre-installed motor protection module inside the terminal box. This device provides for efficient and reliable protection against overheating and overloading as well as phase loss/reversal.

The motor protector comprises a control module and PTC sensors embedded in the motor winding. The close contact between thermistors and windings ensures a very low level of thermal inertia.

The motor temperature is being constantly measured by a PTC thermistor loop connected on S1-S2. If any thermistor exceeds its response temperature, its resistance increases above the trip level (4,500 Ω) and the output relay then trips – i.e. contacts M1-M2 are open. After cooling to below the response temperature (resistance < 2,750 Ω), a 5-minute time delay is activated.

After this delay has elapsed, the relay is once again pulled in – i.e. contacts M1-M2 are closed. The time delay may be cancelled by means of resetting the mains (L-N -disconnect) for approximately 5 sec.

When present, the LED on module will lighten as follows in case of overheat:

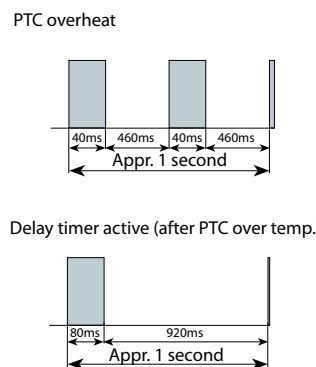

Phase sequence and reverse rotation protection

Use a phase meter to establish the phase orders and connect line phases L1, L2 and L3 to terminals T1, T2 and T3, respectively. The compressor will only operate properly in a single direction, and the motor is wound so that if the connections are correct, the rotation will also be correct.

Compressor model CH290 & CH485 are delivered with an electronic module which provides protection against phase reversal and phase loss at start-up. Apply the recommended wiring diagrams from section “Suggested wiring diagram logic”. The circuit should be thoroughly checked in order to determine the cause of the phase problem before re-energizing the control circuit. The phase sequencing and phase loss monitoring functions are active during a 5-sec window 1 second after compressor start-up (power on L1-L2-L3).

Should one of these parameters be incorrect, the relay would lock out (contact M1-M2 open). When present, the led on the module will show the following blink code:

In case of phase reverse error:

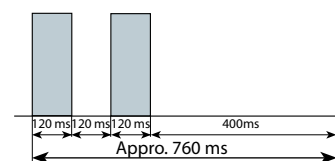

In case of phase loss error:

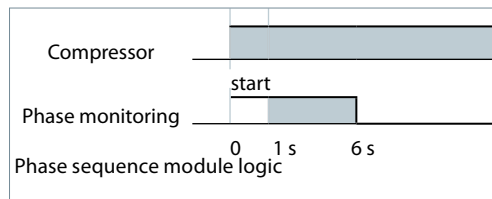
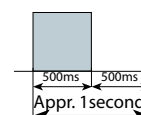

The lockout may be cancelled by resetting the power mains (disconnect L-N) for approximately 5 seconds.

Voltage imbalance

The operating voltage limits are shown in the table section “Motor voltage”. The voltage applied to the motor terminals must lie within these table limits during both start-up and normal operations. The maximum allowable voltage

imbalance is 2%. Voltage imbalance causes high amperage over one or several phases, which in turn leads to overheating and possible motor damage. Voltage imbalance is given by the formula:

$$\% \text{ voltage imbalance} = \frac{|V_{avg} - V_{1-2}| + |V_{avg} - V_{1-3}| + |V_{avg} - V_{2-3}|}{2 \times V_{avg}} \times 100$$

Vavg = Mean voltage of phases 1, 2, 3.

V1-3 = Voltage between phases 1 and 3.

V1-2 = Voltage between phases 1 and 2.

V2-3 = Voltage between phases 2 and 3.

The scroll compressor application range is influenced by several parameters which need to be monitored for a safe and reliable operation.

These parameters and the main recommendations for good practice and safety devices are explained hereunder.

- **Refrigerant and lubricants**
- **Motor supply**
- **Compressor ambient temperature**
- **Application envelope** (evaporating temperature, condensing temperature, return gas temperature)

Refrigerant and lubricants

General information

When choosing a refrigerant, different aspects must be taken into consideration:

- Legislation (now and in the future)
- Safety
- Application envelope in relation to expected running conditions
- Compressor capacity and efficiency

- Compressor manufacturer recommendations and Guidelines

Additional points could influence the final choice:

- Environmental considerations
- Standardisation of refrigerants and lubricants
- Refrigerant cost
- Refrigerant availability

Danfoss Commercial Compressors, along with the whole refrigeration and air conditioning industry, shares today's concern about the environmental issues that are ozone depletion, global warming and overall energy consumption. Usual HCFCs refrigerant fluids such as R22 are known to be implicated in these harmful phenomena, especially ozone depletion due to their chlorinated content. These substances are scheduled to be phased-out from production

and use in coming years, in accordance with the international Montreal Protocol (1984).

As a result, new chlorine-free molecules have been recently developed and are now ready to replace former fluids. Among those refrigerants, the HFC blend R410A is admitted by a great majority of manufacturers to be the most promising in terms of environmental impact, stability and efficiency, and is already seen as the R22 replacement.

	Refrigerant	R22	R407C	R410A
Chemical properties	Chlorine content	yes	no	no
	Zeotropic	pure refrigerant	zeotropic mixture	near azeotropic mixture
	Composition	R22	R32/R125/R134a	R32/R125
Environmental impact	ODP	0.05	0	0
	GWP	1500	1526	1725
Thermodynamic properties	Vapour pressure (bar) at 25°C	10.4	11.9	16.5
	Cooling capacity of liquid (kJ/kg.K) at 25°C	1.24	1.54	1.84
	Cooling capacity of vapor (kJ/kg.K) at 1 atm, 25 °C	0.657	0.829	0.833
	Temperature glide (°C)	0	7.4	<0.2

R410A

CH compressors are to be used with R410A refrigerant, with polyolester oil.

- R410A's superior thermodynamical properties compared to R22 and R407C refrigerants allow for today's massive – and necessary – switch to high efficiency systems.
- Zero Ozone Depletion Potential (ODP): R410A does not harm the ozone layer.
- Global warming potential (GWP): R410A shows a relatively high warming potential. However, the GWP index denotes direct warming effect, which is relevant only in case of release to the atmosphere. A more accurate index is T.E.W.I., for Total Equivalent Warming Impact, which takes into account indirect contributions due to running energy costs.

- Because of the higher system efficiency it allows to achieve, R410A is in this regard the best refrigerant.
- As a near-azeotropic mixture, refrigerant R410A behaves like an homogeneous substance, whereas other zeotropic mixtures such as R407C and other blends suffer a temperature glide during phase change that lessens thermal efficiency and makes them difficult to transfer from a container to another.
- Reduced refrigerant mass flow, permitted by a higher heat capacity, induce a lower sound level of the installation as well as more compact and lighter systems.

Application Guidelines
Operating conditions
POE oil

Polyolester oil (POE) is miscible with HFC's (while mineral oil is not), but has to be evaluated regarding lubrication ability in compressors. POE oil has better thermal stability than refrigerant mineral oil.

POE is more hygroscopic and also holds moisture more tight than mineral oil. It also chemically reacts with water leading to acid and alcohol formation.

Motor supply

CH scroll compressors can be operated at nominal voltages as indicated section "Motor voltage". Under-voltage and over-voltage

operation is allowed within the indicated voltage ranges. In case of risk of under-voltage operation, special attention must be paid to current draw.

Compressor ambient temperature

CH compressors can be applied from -35°C to 51°C ambient temperature. The compressors are designed as 100 % suction gas cooled

without need for additional fan cooling. Ambient temperature has very little effect on the compressor performance.

High ambient temperature

In case of enclosed fitting and high ambient temperature it's recommend to check the temperature of power wires and conformity to their insulation specification. In case of safe tripping by the internal compressor overload

protection the compressor must cool down to about 60°C before the overload will reset. A high ambient temperature can strongly delay this cool-down process.

Low ambient temperature

Although the compressor itself can withstand low ambient temperature, the system may require specific design features to ensure safe

and reliable operation. See section 'Specific application recommendations'.

Application envelope

The operating envelopes for CH scroll compressors is given in the figure below, where the condensing and evaporating temperatures represent the range for steady-state operation. Under transient conditions, such as start-up and defrost, the compressor may operate outside this envelope for short periods. The operating limits serve to define the envelope within which reliable operations of the compressor are guaranteed:

- Maximum discharge gas temperature: +135°C,
- Due to the risk of liquid flood back the minimum suction superheat allowed is 5 K
- Maximum superheat of 30 K,
- Minimum and maximum evaporating and condensing temperatures as per the operating envelopes.

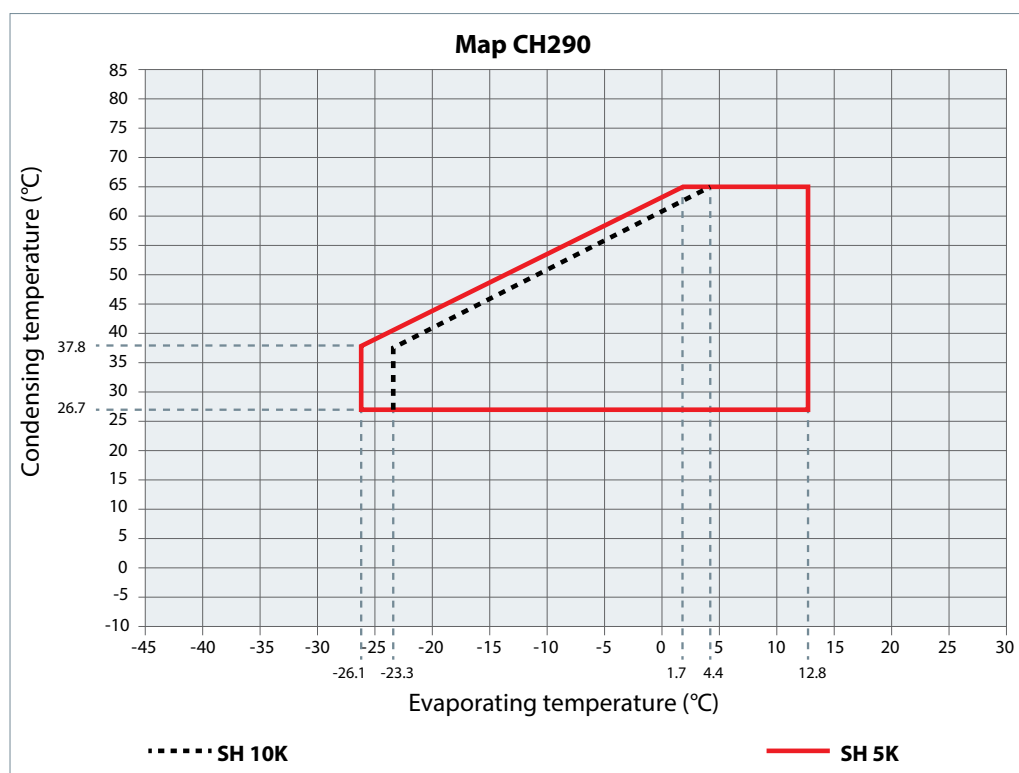

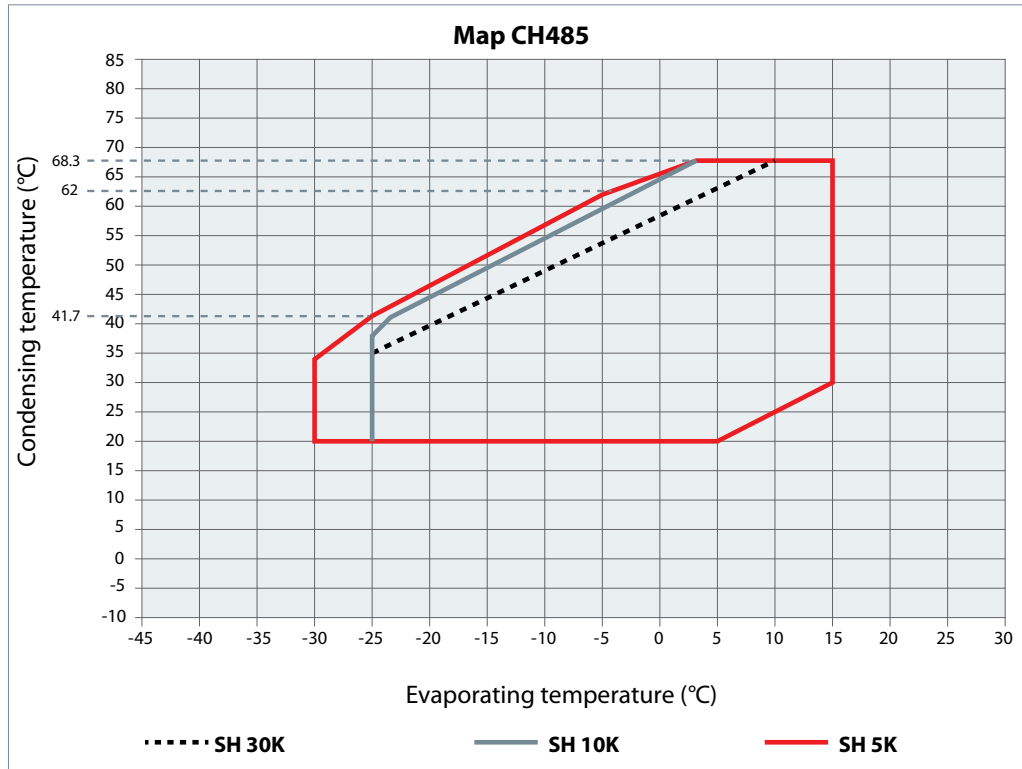

Discharge temperature protection

The discharge gas temperature must not exceed 135°C.

The discharge gas thermostat accessory kit (code 7750009) includes all components required for installation as shown below. The thermostat must be attached to the discharge line within 150 mm from the compressor discharge port and must be thermally insulated and tightly fixed on the pipe.

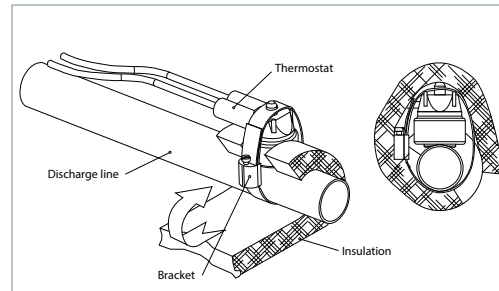

A DGT protection is required if the high and low pressure switch settings do not protect the compressor against operations beyond its specific application envelope. Please refer to the examples below, which illustrate where DGT protection is required (Ex.1) and where it is not (Ex.2). A discharge gas temperature protection device must be installed on all heat pumps. In reversible air-to-air and air-to-water heat pumps

the discharge temperature must be monitored during development test by the equipment manufacturer. The DGT should be set to open at a discharge gas temperature of 135°C. The compressor must not be allowed to cycle on the discharge gas thermostat. Continuous operations beyond the compressor's operating range will cause serious damage to the compressor!

Example 1 (R410A)
 LP switch setting:
 LP1 = 3.3 bar (g) (-15.5°C)
 HP switch setting:
 HP1 = 38 bar (g) (62°C)
 Risk of operation beyond the application envelope.
 DGT protection required.

Example 2 (R410A)
 LP switch setting:
 LP2 = 4.6 bar (g) (-10.5°C)
 HP switch setting:
 HP2 = 31 bar (g) (52°C)
 No risk of operation beyond the application envelope.
 No DGT protection required.

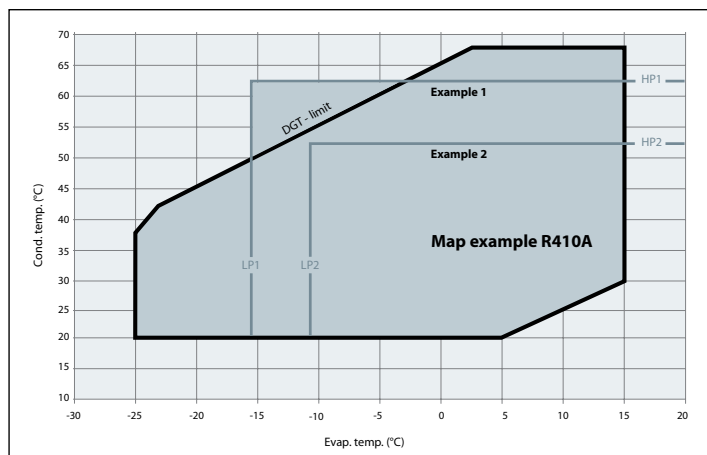

High and low pressure protection
High pressure

A high-pressure (HP) safety switch is required to shut down the compressor should the discharge pressure exceed the values shown in the table section "System pressure test". The high-pressure switch can be set to lower values depending on the application and ambient conditions. The HP

switch must either be placed in a lockout circuit or consist of a manual reset device to prevent cycling around the high-pressure limit. If a discharge valve is used, the HP switch must be connected to the service valve gauge port, which must not be isolated.

Low pressure

A low-pressure (LP) safety switch must be used. Deep vacuum operations of a scroll compressor can cause internal electrical arcing and scroll instability. Danfoss CH Scroll compressors exhibit high volumetric efficiency and may draw very low vacuum levels, which could induce such a problem. The minimum low-pressure safety switch (loss-of-charge safety switch) setting is

given in the following table. For systems without pump-down, the LP safety switch must either be a manual lockout device or an automatic switch wired into an electrical lockout circuit. The LP switch tolerance must not allow for vacuum operations of the compressor. LP switch settings for pump-down cycles with automatic reset are also listed in the table below.

Pressure settings		R410A
Working pressure range high side	bar (g)	16.2 - 41.6
Working pressure range low side	bar (g)	2.15 - 10.7
Maximum high pressure safety switch setting	bar (g)	46.1
Minimum low pressure safety switch setting *	bar (g)	1.5
Minimum low pressure pump-down switch setting **	bar (g)	2.15

* LP safety switch shall never be bypassed and shall have no time delay.

** Recommended pump-down switch settings: 1.5 bar below nominal evap. pressure with minimum of 2.15 bar(g)

Note that these two different low pressure switches also require different settings. The low pressure pump down switch setting must always be within the operating envelope, for example 2.15 bar for R410A. The compressor can be operated full time under such condition.

The minimum low pressure safety switch setting may be outside the normal operating envelope and should only be reached in exceptional (emergency) situations, for example 1.5 bar for R410A.

Cycle rate limit

Danfoss recommends a restart delay timer to limit compressor cycling. The timer prevents reverse compressor rotation, which may occur during brief power interruptions.

The system must be designed in a way that guarantees a minimum compressor running time of 2 minutes so as to provide for sufficient motor cooling after start-up along with proper oil return. Note that the oil return may vary since it depends upon system design. There must be no more than 12 starts per hour, a number higher than 12 reduces the service life of the motor-

compressor unit. A three-minute (180- sec) time out is recommended.

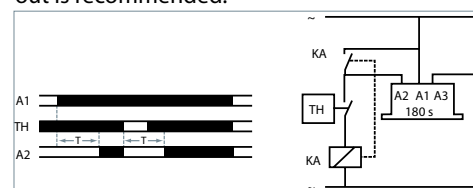

Please contact Danfoss Technical Support for any deviation from these guidelines.

General

Successful application of scroll compressors is dependent on careful selection of the compressor for the application. If the compressor is not correct for the system, it will operate

beyond the limits given in this manual. Poor performance, reduced reliability, or both may result.

Essential piping design recommendations

The working pressure in systems with R410A is about 60% higher than in systems with R22 or R407C. Consequently, all system components and piping must be designed for this higher pressure level.

compared to R22 / R407C systems. Take care not to create too high pressure drops since in R410A systems the negative impact of high pressure drops on the system efficiency is stronger than in R22/R407C systems.

Proper piping practices should be employed to ensure adequate oil return, even under minimum load conditions with special consideration given to the size and slope of the tubing coming from the evaporator. Tubing returns from the evaporator should be designed so as not to trap oil and to prevent oil and refrigerant migration back to the compressor during off-cycles.

Piping should be designed with adequate three-dimensional flexibility. It should not be in contact with the surrounding structure, unless a proper tubing mount has been installed. This protection proves necessary to avoid excess vibration, which can ultimately result in connection or tube failure due to fatigue or wear from abrasion. Aside from tubing and connection damage, excess vibration may be transmitted to the surrounding structure and generate an unacceptable noise level within that structure as well. For more information on noise and vibration, see the section on: "Sound and vibration management".

In systems with R410A, the refrigerant mass flow will be lower compared to R22/R407C systems. To maintain acceptable pressure drops and acceptable minimum gas velocities, the refrigerant piping must be reduced in size

Suction lines

If the evaporator lies above the compressor, as is often the case in split or remote condenser systems, the addition of a pump-down cycle is strongly recommended. If a pump-down cycle were to be omitted, the suction line must have a loop at the evaporator outlet to prevent refrigerant from draining into the compressor during off-cycles.

If the evaporator were situated below the compressor, the suction riser must be trapped so as to prevent liquid refrigerant from collecting at the outlet of the evaporator while the system is idle, which would mislead the expansion valve's sensor (thermal bulb) at start-up.

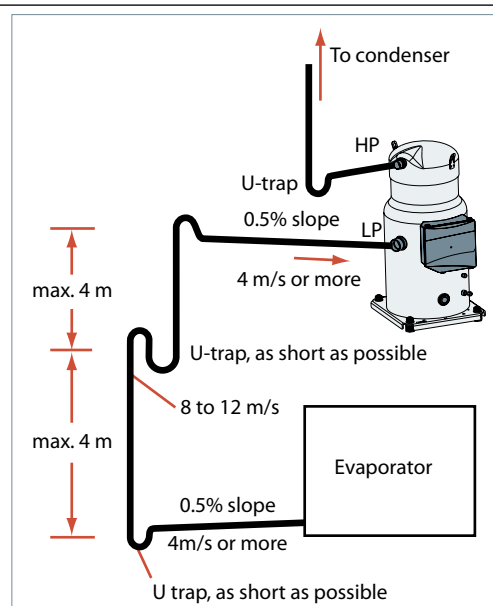
Discharge lines

When the condenser is mounted at a higher position than the compressor, a suitably sized "U"-shaped trap close to the compressor is necessary to prevent oil leaving the compressor from draining back to the discharge side of the compressor during off cycle. The upper loop also helps avoid condensed liquid refrigerant from draining back to the compressor when stopped.

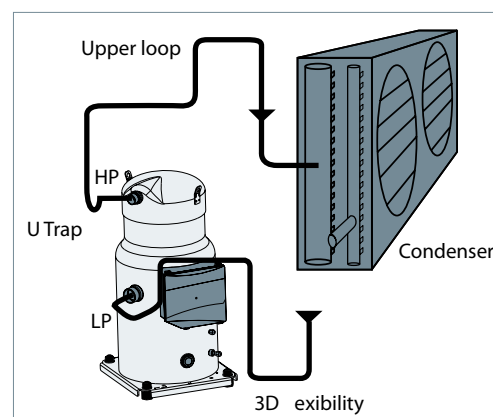

Heat exchangers

To obtain optimum efficiency of the complete refrigerant system, optimised R410A heat exchangers must be used. R410A refrigerant has good heat transfer properties: it is worthwhile designing specific heat exchangers to gain in size and efficiency.

An evaporator with optimised R410A distributor and circuit will give correct superheat at outlet and optimal use of the exchange surface. This is critical for plate evaporators that have generally a shorter circuit and a lower volume than shell and tubes and air cooled coils.

For all evaporator types a special care is required for superheat control leaving the evaporator and oil return.

A sub-cooler circuit in the condenser that creates high sub cooling will increase efficiency at high condensing pressure. In R410A systems the positive effect of sub cooling on system efficiency will be significantly larger than in R22/R407C systems.

Furthermore, for good operation of the expansion device and to maintain good efficiency in the evaporator it is important to have an appropriate sub cooling. Without adequate sub cooling, flash gas will be formed at the expansion device resulting in a high degree of vapour at the expansion device inlet leading to low efficiency.

Refrigerant charge limit

Danfoss CH compressors can tolerate liquid refrigerant up to a certain extend without major problems. However, excessive liquid refrigerant in the compressor is always unfavorable for service life. Besides, the installation cooling capacity may be reduced because of the evaporation taking place in the compressor and/or the suction line instead of the evaporator. System design must be such that the amount of liquid refrigerant in the compressor is limited. In this respect, follow the

guidelines given in the section: "Essential piping design recommendations" in priority.

Use the tables below to quickly evaluate the required compressor protection in relation with the system charge and the application.

Model	Refrigerant charge limit (kg)
CH290	13.5
CH485	17

	BELOW charge limit	ABOVE charge limit
Cooling only systems, Packaged units	<input checked="" type="checkbox"/> No test or additional safeties required	REQ Refrigerant migration and flood back test REQ Sump heater
Cooling only systems with remote condenser and split system units	REC Refrigerant migration and flood back test REC Sump heater	REQ Refrigerant migration and flood back test REQ Sump heater REC Liquid receiver (in association with LLSV and pump down)
Reversible heat pump system	REQ Specific tests for repetitive flood back REQ Sump heater REQ Defrost test	For more details, refer to section "Reversible heat pump system"

REC Recommended **REQ** Required No test or additional safeties required

Note: for special conditions such as low ambient temperature, low refrigerant load or brazed plate heat exchangers please refer to corresponding sections.

More detailed information can be found in the paragraphs hereafter.
Please contact Danfoss Technical Support for any deviation from these guidelines.

Off-cycle migration

Off-cycle refrigerant migration is likely to occur when the compressor is located at the coldest part of the installation, when the system uses a bleed-type expansion device, or if liquid is allowed to migrate from the evaporator into the compressor sump by gravity. If too much liquid refrigerant accumulates in the sump it will saturate the oil and lead to a flooded start: when the compressor starts running again, the refrigerant evaporates abruptly under the sudden decrease of the bottom shell pressure, causing the oil to foam. In extreme situations, this might result in liquid slugging (liquid entering the scroll elements), which must be avoided as it causes irreversible damage to the compressor.

- Stabilize the non-running system at 5°C ambient temperature,
- Raise the ambient temperature to 20°C and keep it for 10 minutes,
- Start the compressor and monitor sump temperature, sight glass indication and sound level.

The presence of liquid in the crankcase can be easily detected by checking the sump level through the oil sight glass. Foam in the oil sump indicates a flooded start.

Danfoss CH scroll compressors can tolerate occasional flooded starts as long as the total system charge does not exceed the maximum compressor refrigerant charge. A suitable test to evaluate the risk of off-cycle migration is the following:

A noisy start, oil loss from the sump and sump cool down are indications for migration. Depending on the amount of migration graduate measures shall be taken:

- **Sump heater**
- **Liquid line solenoid valve**
- **Pump down cycle**

Sump heater

The surface sump heaters are designed to protect the compressor against off-cycle migration of refrigerant.

When the compressor is idle, the oil temperature in the sump of the compressor must be maintained at no lower than 10 K above the saturation temperature of the refrigerant on the low-pressure side. This requirement ensures that the liquid refrigerant is not accumulating in the sump. A sump heater is only effective if capable of sustaining this level of temperature difference. Tests must be conducted to ensure that the appropriate oil temperature is maintained under all ambient conditions (temperature and wind). Note that below -5°C ambient temperature and a wind speed of above 5m/second, we recommend that the heaters be thermally insulated in order to limit the surrounding energy losses.

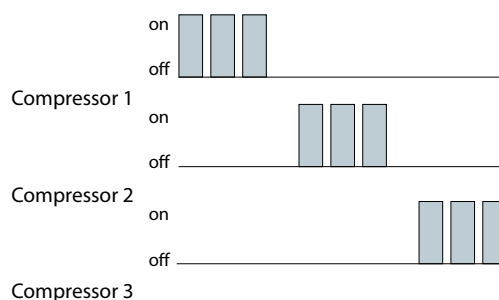

The heater must be energized whenever the compressor is off to avoid liquid refrigerant entering the compressor.

Since the total system charge may be undefined, a sump heater is recommended on all stand-alone compressors and split systems. In addition, any system containing a refrigerant charge in excess of the maximum recommended system charge for compressors requires a sump heater. A sump heater is also required on all reversible cycle applications.

Provide separate electrical supply for the heaters so that they remain energized even when the machine is out of service (e.g. seasonal shutdown).

Surface sump heater accessories are available from Danfoss (see section "Accessories").

At initial start-up or after power shortage, it is recommended to energize surface sump heater to remove refrigerant 6 hours in advance. A quicker start-up is possible by "jogging" the compressor to evacuate refrigerant in the compressor.

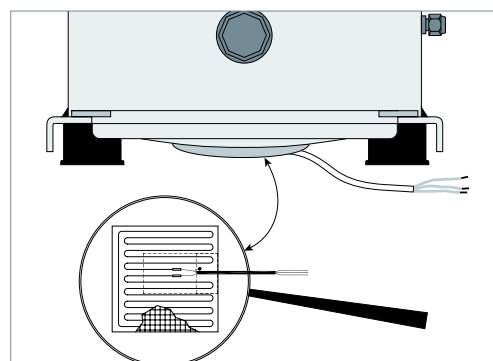

Liquid line solenoid valve (LLSV)

A LLSV may be used to isolate the liquid charge on the condenser side, thereby preventing against charge transfer or excessive migration to the compressor during off-cycles. The quantity of

refrigerant on the low-pressure side of the system can be further reduced by using a pump-down cycle in association with the LLSV.

Pump-down cycle

Pump-down cycle represents one of the most effective ways to protect against the off-cycle migration of liquid refrigerant. Once the system has reached its set point and is about to shut off, the LLSV on the condenser outlet closes. The compressor then pumps the majority of the refrigerant charge into the condenser and receiver before the system stops on the low pressure pump-down switch. This step reduces the amount of charge on the low side in order to prevent off-cycle migration. The recommended low-pressure pump-down switch setting is 1.5 bar below the nominal evaporating pressure. It shall not be set lower than 2.15 bar(g). For suggested wiring diagrams, please see section «Suggested wiring diagrams logic».

a low pressure safety switch without any delay timer is mandatory. While the thermostat is off, the number of pressure switch resets should be limited to avoid short cycling of the compressor. Use dedicated wiring and an additional relay which allows for one shot pump-down.

The pump-down allows to store all the refrigerant in the high pressure side circuit. On unitary or close-coupled systems, where the system refrigerant charge is expected to be both correct and definable the entire system charge may be stored in the condenser during pump-down if all components have been properly sized. Other application needs a liquid receiver to store the refrigerant.

Tests for pump down cycle approval:

- As the pump-down switch setting is inside the application envelope, tests should be carried out to check unexpected cut-out during transient conditions (ie. defrost – cold starting). When unwanted cut-outs occur, the low pressure pump-down switch can be delayed. In this case

Receiver dimensioning requires special attention. The receiver shall be large enough to contain part of the system refrigerant charge but it shall not be dimensioned too large. A large receiver easily leads to refrigerant overcharging during maintenance operation.

Liquid flood back

During normal operation, refrigerant enters the compressor as a superheated vapour. Liquid flood back occurs when a part of the refrigerant entering the compressor is still in liquid state. Danfoss CH scroll compressors can tolerate occasional liquid flood back. However system design must be such that repeated and excessive flood back is not possible.

A continuous liquid flood back will cause oil dilution and, in extreme situations lead to lack of lubrication and high rate of oil leaving the compressor.

Liquid flood back test - Repetitive liquid flood back testing must be carried out under expansion valve threshold operating conditions: a high pressure ratio and minimum evaporator load, along with the measurement of suction superheat, oil sump temperature and discharge gas temperature.

the saturated suction temperature, or should the discharge gas temperature be less than 35K above the saturated discharge temperature, this indicates liquid flood back.

During operations, liquid flood back may be detected by measuring either the oil sump temperature or the discharge gas temperature. If at any time during operations, the oil sump temperature drops to within 10K or less above

Continuous liquid flood back can occur with a wrong dimensioning, a wrong setting or malfunction of the expansion device or in case of evaporator fan failure or blocked air filters. A suction accumulator providing additional protection as explained hereunder can be used to solve light continuous liquid flood back.

Suction accumulator: a suction accumulator offers protection against refrigerant flood back at start-up, during operations or defrosting by trapping the liquid refrigerant upstream from the compressor. The suction accumulator also protects against off-cycle migration by providing additional internal free volume to the low side of the system.

charge as well as the gas velocity in the suction line. The accumulator should not be sized for less than 50 % of the total system charge. Tests must be conducted to determine the actual refrigerant holding capacity needed for the application.

A suction accumulator must be carefully dimensioned, taking into account the refrigerant

Depending on the operating conditions it may happen that the recommended connections of the accumulator are one size smaller than the suction line.

Low ambient application
Low ambient start-up

Under cold ambient conditions (<math><0^{\circ}\text{C}</math>), upon start-up the pressure in the condenser may be so low that a sufficient pressure differential across the expansion device cannot be developed to properly feed the evaporator.

As a result, the compressor may go into a deep vacuum, which can lead to compressor failure due to internal arcing and instability in the scroll wraps. Under no circumstances should the compressor be allowed to operate under vacuum. The low-pressure control must be set in accordance with the table section "Low pressure" in order to prevent this from happening. Early

feeding of the evaporator and management of the discharge pressure could help to attenuate these effects.

Low pressure differentials can also cause the expansion device to «hunt» erratically, which might cause surging conditions within the evaporator, with liquid spillover into the compressor. This effect is most pronounced during low load conditions, which frequently occur during low ambient conditions.

Low ambient operations

The Danfoss CH scroll compressor requires a minimum pressure differential of 6 to 7 bar between the suction and discharge pressures to force the orbiting scroll down against the oil film on the thrust bearing. Anything less than this differential and the orbiting scroll can lift up, causing a metal-to-metal contact. It is therefore necessary to maintain sufficient discharge pressure in order to ensure this pressure differential. Care should be taken during low ambient operations when heat removal from air-cooled condensers is greatest and head pressure control may be required for low ambient temperature applications. Operation under low pressure differential may be observed by a significant increase in the sound power level generated by the compressor.

It is recommended that the unit be tested and monitored at minimum load and low ambient conditions as well. The following considerations should be taken into account to ensure proper system operating characteristics.

Expansion device: The expansion device should be sized to ensure proper control of the refrigerant flow into the evaporator. An oversized valve may result in erratic control. This can lead to liquid refrigerant entering the compressor if the expansion valve does not provide stable refrigerant super-heat control under varying loads. The superheat setting of the expansion device should be sufficient to ensure proper superheat levels during low loading periods. A minimum of 5 K stable superheat is required.

Head pressure control under low ambient conditions: Several possible solutions are available to prevent the risk of compressor to vacuum and low pressure differential between the suction and discharge pressures.

In air-cooled machines, cycling the fans with a head pressure controller will ensure that the fans remain off until the condensing pressure has reached a satisfactory level. Variable speed fans can also be used to control the condensing pressure. In water-cooled units, the same can be performed using a water regulator valve that is also operated by head pressure, thereby ensuring that the water valve does not open until the condensing pressure reaches a satisfactory level.

The minimum condensing pressure must be set at the minimum saturated condensing temperature shown in the application envelopes.

Under very low ambient conditions, in which testing has revealed that the above procedures might not ensure satisfactory condensing and suction pressures, the use of a head pressure control valve is recommended. Note: This solution requires extra refrigerant charge, which can introduce other problems. A non-return valve in the discharge line is recommended and special care should be taken when designing the discharge line.

For further information, please contact Danfoss.

Application Guidelines

Specific application recommendations

Sump heaters

Sump heaters are strongly recommended on all systems where the compressor is exposed to low ambient temperatures, especially split and remote condenser installations. The sump heater

will minimize refrigerant migration caused by the large temperature gradient between the compressor and the remainder of the system, please refer to section "Accessories".

Low load operation

The compressors should be run for a minimum period in order to ensure that the oil has sufficient time to properly return to the

compressor sumps and that the motor has sufficient time to cool under conditions of lowest refrigerant mass flows.

Brazed plate heat exchangers

A brazed plate heat exchanger needs very little internal volume to satisfy the set of heat transfer requirements. Consequently, the heat exchanger offers very little internal volume for the compressor to draw vapour from on the suction side. The compressor can then quickly enter into a vacuum condition. It is therefore important that the expansion device be sized correctly and that a sufficient pressure differential across the expansion device be available to ensure adequate refrigerant feed into the evaporator. This aspect is of special concern when operating the unit under low ambient and load conditions. For further information on these conditions, please refer to the previous sections.

required. The suction line running from the heat exchanger to the compressor must be trapped to avoid refrigerant migration to the compressor.

When using a brazed plate condenser heat exchanger, a sufficient free volume for the discharge gas to accumulate is required in order to avoid excess pressure build-up. At least 1 meter of discharge line is necessary to generate this volume.

Due to the small volume of the brazed plate heat exchanger, no pump-down cycle is normally

To help reduce the gas volume immediately after start-up even further, the supply of cooling water to the heat exchanger may be opened before the compressor starts up so as to remove superheat and condense the incoming discharge gas more quickly.

Electronic expansion valve

The use of an electronic expansion valve requires a specific compressor start / stop control.

compressor. Ensure that the EXV closes when the supply voltage to the controller is interrupted (ie power cut off) by the use of a battery back-up.

Specific compressor start sequence control has to be set when an electronic expansion valve (EXV) is used. The sequence must be adjusted according to the EXV step motor speed to allow time for the EXV to open before the compressor starts to avoid running under vacuum conditions.

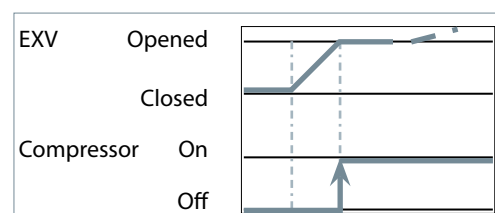

The EXV should be closed at compressor stop not to let refrigerant in liquid phase entering the

Reversible heat pump systems

Transients are likely to occur in reversible heat pump systems, i.e. a changeover cycle from cooling to heating, defrost or low-load short cycles. These transient modes of operation may lead to liquid refrigerant carry-over (or flood back) or excessively wet refrigerant return conditions. As such, reversible cycle applications require specific precautions for ensuring a long compressor life and satisfactory operating characteristics. Regardless of the refrigerant

charge in the system, specific tests for repetitive flood back are required to confirm whether or not a suction accumulator needs to be installed.

The following considerations cover the most important issues when dealing with common applications. Each application design however should be thoroughly tested to ensure acceptable operating characteristics.

Application Guidelines
Specific application recommendations
Sump heaters

Sump heaters are mandatory on reversible cycle applications given the high probability of liquid migration back to the compressor sump

during off-cycles due to the outdoor location of most units and operations during low ambient conditions.

Discharge temperature thermostat

Heat pumps frequently utilize high condensing temperatures in order to achieve a sufficient temperature rise in the medium being heated. At the same time, they often require low evaporating pressures to obtain sufficient temperature differentials between the evaporator and the outside temperature. This situation may result in high discharge temperature; as such, it is mandatory that a discharge gas thermostat be installed on the discharge line to protect

the compressor from excessive temperatures. Operating the compressor at too high discharge temperatures can result in mechanical damage to the compressor as well as thermal degradation of the compressor lubricating oil and a lack of sufficient lubrication. The discharge gas thermostat should be set to shut down the compressor in the event discharge gas rises above 135°C.

Discharge line, reversing valve, solenoid valves

The Danfoss CH scroll compressor is a high volumetric machine and, as such, can rapidly build up pressure in the discharge line if gas in the line becomes obstructed even for a very short period of time which situation may occur with slow-acting reversing valves in heat pumps. Discharge pressures exceeding the operating envelope may result in nuisance high-pressure switch cutouts and place excess strain on both the bearings and motor.

and the reversing valve or any other restriction. This gives sufficient free volume for the discharge gas to collect and to reduce the pressure peak during the time it takes for the valve to change position. At the same time, it is important that the selection and sizing of the reversing or 4-way valve ensure that the valve switches quickly enough to prevent against too high discharge pressure and nuisance high-pressure cutouts. Check with the valve manufacturer for optimal sizing and recommended mounting positions.

To prevent such occurrences, it is important that a 1-meter minimum discharge line length be allowed between the compressor discharge port

Application Guidelines
Specific application recommendations

	<p>In applications with heat recovery or condenser partialisation, servo piloted solenoid valve have to be properly sized or associated with a second small valve in parallel, in order to avoid quick</p>	<p>discharge pressure drops when opening. This phenomenon could lead to hammering effects and create constraints on the non-return valve integrated in discharge fitting.</p>
<p>Defrost and reverse cycle</p>	<p>The Danfoss CH scroll compressor have the ability to withstand a certain amount of liquid refrigerant dynamic slug.</p> <p>When compressors are installed in parallel, in order to limit liquid amount handled per compressor when beginning and ending defrost, it is recommended to avoid running part load (keep all compressors running or keep them stopped when moving 4-way valves).</p> <p>For further details, please refer to Parallel application guidelines</p>	<p>EXV can also be opened when compressors are stopped and before 4 way valve is moving in order to decrease pressure difference. Opening degree and time have to be set in order to keep a minimum pressure difference for 4 way valve moving. Each application design however should be thoroughly tested to ensure acceptable operating characteristics.</p>
<p>Suction line accumulator</p>	<p>The use of a suction line accumulator is strongly recommended in reversible-cycle applications. This because of the possibility of a substantial quantity of liquid refrigerant remaining in the evaporator, which acts as a condenser during the heating cycle.</p> <p>This liquid refrigerant can then return to the compressor, either flooding the sump with refrigerant or as a dynamic liquid slug when</p>	<p>the cycle switches back to a defrost cycle or to normal cooling operations.</p> <p>Sustained and repeated liquid slugging and flood back can seriously impair the oil's ability to lubricate the compressor bearings. This situation can be observed in wet climates where it is necessary to frequently defrost the outdoor coil in an air source heat pump. In such cases a suction accumulator becomes mandatory.</p>
<p>Water utilizing systems</p>	<p>Apart from residual moisture in the system after commissioning, water could also enter the refrigeration circuit during operation. Water in the system shall always be avoided. Not only because it can shortly lead to electrical failure, sludge in sump and corrosion but in particular because it can cause serious safety risks.</p> <p>Common causes for water leaks are corrosion and freezing.</p> <p>Corrosion: Materials in the system shall be compliant with water and protected against corrosion.</p>	<p>Freezing: When water freezes into ice its volume expands which can damage heat exchanger walls and cause leaks. During off periods water inside heat exchangers could start freezing when ambient temperature is lower than 0°C. During on periods ice banking could occur when the circuit is running continuously at too low load.</p> <p>Both situations should be avoided by connecting a pressure and thermostat switch in the safety line.</p>

Application Guidelines Sound and vibration management

Starting sound level

During start-up transients it is natural for the compressor sound level to be slightly higher than during normal running. The CH scroll compressors exhibit very little increased start-up transient sound. If a compressor is miswired, the compressor will run in reverse. Reverse

compressor rotation is characterized by an objectionable sound. To correct reverse rotation, disconnect power and switch any two of the three power leads at the unit contactor. Never switch leads at the compressor terminals.

Running sound level

Compressor acoustic hoods have been developed to meet specific extra-low noise requirements. The covers and bottom insulations

incorporate sound proofing materials and offer excellent high and low frequency attenuation.

Model	50 Hz		Acoustic hood code number	Bottom hood code number ②
	Sound power dB(A)	Attenuation dBA ①		
CH290	82	6	120Z0022	120Z0353
CH485	89	4	120Z0022	120Z0353

Sound power and attenuation are given at ARI conditions, measured in free space

① Attenuation given with acoustic hood only

② Bottom hood is provided in surface sump heater accessories. Additional attenuation is 2 to 4 dBA. Materials are UL approved and RoHS compliant.

Stopping sound level

CH compressors are equipped with a discharge valve which closes at compressor shut down and thus prevents the compressor from running backwards. This reduces the stopping sound to a metallic click caused by the closing valve.

When the pressure difference or gas flow at shut down should be very low, this can delay the discharge valve from closing and lead to a longer noise duration.

Sound generation in a refrigeration or air conditioning system

Typical sound and vibration in refrigeration and air conditioning systems encountered by design and service engineers may be broken down into the following three source categories.

Sound radiation: this generally takes an airborne path.

Mechanical vibrations: these generally extend along the parts of the unit and structure.

Gas pulsation: this tends to travel through the cooling medium, i.e. the refrigerant.

The following sections focus on the causes and methods of mitigation for each of the above sources.

Compressor sound radiation

For sound radiating from the compressor, the emission path is airborne and the sound waves are travelling directly from the machine in all directions.

The CH scroll compressors are designed to be quiet and the frequency of the sound generated is pushed into the higher ranges, which not only are easier to reduce but also do not generate the penetrating power of lower frequency sound.

Use of sound-insulation materials on the inside of unit panels is an effective means of substantially reducing the sound being transmitted to the outside. Ensure that no components capable of transmitting sound/vibration within the unit come into direct contact with any non-insulated parts on the walls of the unit.

Because of the unique Danfoss design of a full-suction gas-cooled motor, compressor body insulation across its entire operating range is possible. Acoustic hoods are available from Danfoss as accessories. They have been developed to meet specific extra low noise requirements. They incorporate sound proofing materials and offer excellent high and low frequency alternative.

These hoods are quick and easy to install and do not increase the overall size of the compressors to a great extend.

Refer to section "Running sound level" for sound attenuation and code numbers.

Mechanical vibrations

Vibration isolation constitutes the primary method for controlling structural vibration. Danfoss CH scroll compressors are designed to produce minimal vibration during operations. Once the supplied rubber grommets have been properly mounted, vibrations transmitted from the compressor base plate to the unit are held to a strict minimum. In addition, it is extremely important that the frame supporting the mounted compressor be of sufficient mass and stiffness to help dampen any residual vibration potentially transmitted to the. For further information on mounting requirements, please refer to the section on mounting assembly.

Note: For parallel assemblies see specific recommendations in Danfoss parallel application guidelines (Rigid mounting).

The tubing should be designed so as to both reduce the transmission of vibrations to other structures and withstand vibration without incurring any damage. Tubing should also be designed for three-dimensional flexibility. For more information on piping design, please see the section entitled "Essential piping design considerations".

Gas pulsation

The Danfoss CH scroll compressors have been designed and tested to ensure that gas pulsation has been optimised for the most commonly encountered air conditioning pressure ratio. On heat pump installations and other installations where the pressure ratio lies beyond the typical range, testing should be conducted

under all expected conditions and operating configurations to ensure that minimum gas pulsation is present. If an unacceptable level is identified, a discharge muffler with the appropriate resonant volume and mass should be installed. This information can be obtained from the component manufacturer.

Each CH compressor is shipped with printed Instructions for installation. These instructions can also be downloaded from our web site:

www.danfoss.com or directly from: <http://www.danfoss.com/China/>

Compressor handling and storage

Each Danfoss CH scroll compressor is equipped with two lift rings on the top shell. Always use both these rings when lifting the compressor. Use lifting equipment rated and certified for the weight of the compressor. A spreader bar rated for the weight of the compressor is highly recommended to ensure a better load distribution. The use of lifting hooks closed with a clasp and certified to lift the weight of the compressor is also highly recommended. Always respect the appropriate rules concerning lifting objects of the type and weight of these compressors.

Maintain the compressor in an upright position during all handling man oeuvres (maximum of 15° from vertical).

⚠ Never use only one lifting lug to lift the compressor. The compressor is too heavy for the single lug to handle, and the risk is run that the lug could separate from the compressor with extensive damage and possible personal injury as a result.

Store the compressor not exposed to rain, corrosive or flammable atmosphere and between -35°C and 51°C when charged with R410A refrigerant and between -35°C and 70°C when charged with nitrogen.

⚠ When the compressor is mounted as part of an installation, never use the lift rings on the compressor to lift the installation. The risk is run that the lugs could separate from the compressor or that the compressor could separate from the base frame with extensive damage and possible personal injury as a result.

Never apply force to the terminal box with the intention of moving the compressor, as the force placed upon the terminal box can cause extensive damage to both the box and the components contained inside.

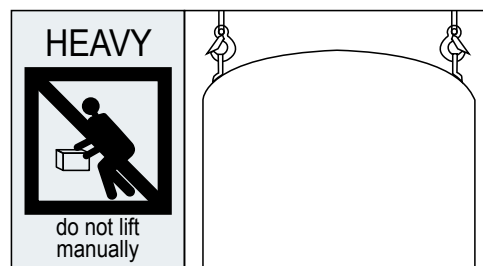

Compressor mounting

Maximum inclination from the vertical plane while operating must not exceed 3 degrees.

Mounting

Compressors CH290 & 485 dedicated for parallel (versions AA and AB) mounting come delivered with rigid mounting spacers for parallel mounting.

flat washer and the steel mounting sleeve is established. The grommets attenuate to a great extent the transmission of compressor vibrations to the base frame.

CH290 used in single applications, are delivered with flexible grommets. The grommets must be compressed until contact between the

The required bolt size for the CH290 & 485 compressors is HM8-55. This bolt must be tightened to a torque of 21 Nm.

Manifoldable compressor with rigid spacers

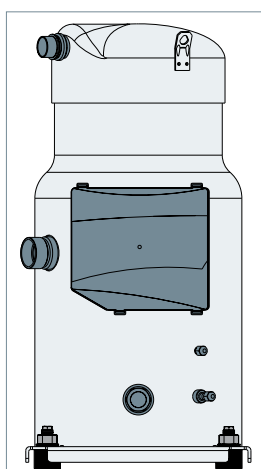

Single compressor with rubber grommets

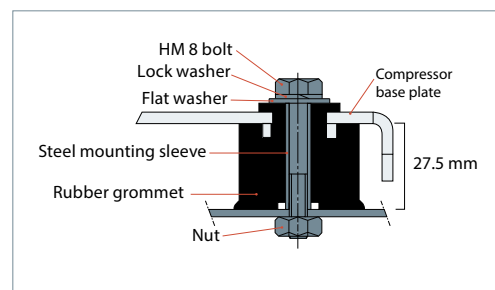
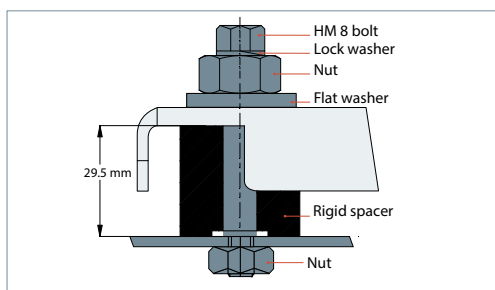
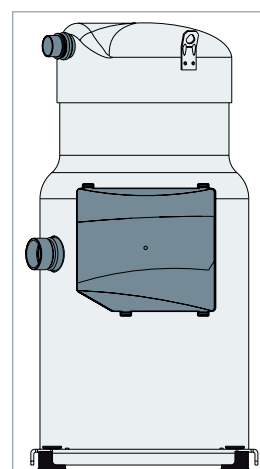

Compressor holding charge

Each compressor is shipped with a nominal dry nitrogen holding charge between 0.3 and 0.7 bar and is sealed with elastomer plugs.

first and the discharge plug afterwards. The plugs shall be removed only just before connecting the compressor to the installation in order to avoid moisture from entering the compressor. When the plugs are removed, it is essential to keep the compressor in an upright position so as to avoid oil spillage.

Before the suction and discharge plugs are removed, the nitrogen holding charge must be released via the suction schrader valve to avoid an oil mist blowout. Remove the suction plug

System cleanliness

The refrigerant compression system, regardless of the type of compressor used, will only provide high efficiency and good reliability, along with a long operating life, if the system contains solely the refrigerant and oil it was designed for. Any other substances within the system will not improve performance and, in most cases, will be highly detrimental to system operations.

The presence of non-condensable substances and system contaminants such as metal shavings, solder and flux, have a negative impact on compressor service life. Many of these contaminants are small enough to pass through a mesh screen and can cause considerable damage within a bearing assembly. The use of highly hygroscopic polyol ester oil in R410A compressors requires that the oil be exposed to the atmosphere as little as possible. System

contamination is one of main factors affecting equipment reliability and compressor service life. It is important therefore to take system cleanliness into account when assembling a refrigeration system.

During the manufacturing process, circuit contamination may be caused by:

- Brazing and welding oxides,
- Filings and particles from the removal of burrs in pipe-work,
- Brazing flux,
- Moisture and air.

Consequently, when building equipment and assemblies, the precautions listed in the following paragraphs must be taken.

Tubing

Only use clean and dehydrated refrigeration grade copper tubing. Tube-cutting must be carried out so as not to deform the tubing roundness and to ensure that no foreign debris remains within the tubing. Only refrigerant grade fittings should be used and these must be of

both a design and size to allow for a minimum pressure drop through the completed assembly. Follow the brazing instructions on next pages. Never drill holes into parts of the pipe-work where filings and particles can not be removed.

Brazing and soldering

Do not bend the compressor discharge or suction lines or force system piping into the compressor connections, because this will increase stresses that are a potential cause of failure. Recommended brazing procedures and material,

are described section "Compressor connection". These operations must be performed by a qualified personnel in compliance with all pertinent practices and safety procedures.

Copper to copper connections

When brazing copper-to-copper connections, the use of copper/phosphorus brazing alloy containing 5% silver or more with a melting

temperature of below 800°C is recommended. No flux is required during brazing.

Dissimilar metals connection

When manipulating dissimilar metals such as copper and brass or steel, the use of silver solder (5% or more) and anti-oxidant flux is necessary.

Please contact Danfoss Technical support for any deviation from this guidelines.

Compressor connection

When brazing the compressor fittings, do not overheat the compressor shell, which could severely damage certain internal components due to excessive heating. Use of a heat shield and/or a heat-absorbent compound is highly recommended. Due to the relatively sizable tubing and fitting diameters a double-tipped torch using acetylene is recommended for brazing operation on CH scroll compressors.

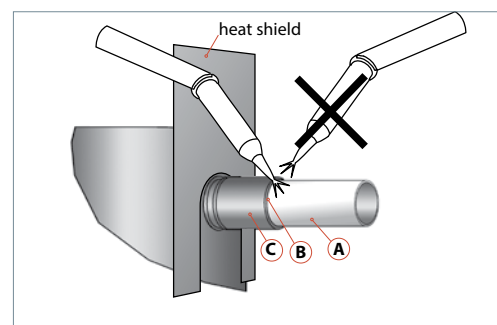

For brazing the suction and discharge connections, the following procedure is advised:

- Make sure that no electrical wiring is connected to the compressor.
- Protect the terminal box and compressor painted surfaces from torch heat damage (see diagram).
- Remove the Teflon gaskets when brazing rotolock connectors with solder sleeves.
- Use only clean refrigeration-grade copper tubing and clean all connections.
- Use brazing material with a minimum of 5% silver content.
- Purge nitrogen or CO₂ through the compressor in order to prevent against oxidation and flammable conditions. The compressor should not be exposed to the open air for extended periods.
- Use of a double-tipped torch is recommended.
- Apply heat evenly to area A until the brazing temperature is reached. Move the torch to area B and apply heat evenly until the brazing temperature has been reached there as well, and then begin adding the brazing material. Move the torch evenly around the joint, in applying only enough brazing material to flow the full circumference of the joint.
- Move the torch to area C only long enough to draw the brazing material into the joint, but not into the compressor.

- Remove all remaining flux once the joint has been soldered with a wire brush or a wet cloth. Remaining flux would cause corrosion of the tubing.

In addition, for discharge connections equipped with a non return valve integrated in discharge fitting the direction of the torch has to be as described on the picture, and maximum brazing time should be less than 2 minutes to avoid NRVI damages.

Ensure that no flux is allowed to enter into the tubing or compressor. Flux is acidic and can cause substantial damage to the internal parts of the system and compressor.

The polyolester oil used in CH compressors is highly hygroscopic and will rapidly absorb moisture from the air. The compressor must therefore not be left open to the atmosphere for a long period of time. The compressor fitting plugs shall be removed just before brazing the compressor. The compressor should always be the last component brazed into the system

⚠ Before eventual unbrazing the compressor or any system component, the refrigerant charge must be removed from both the high- and low-pressure sides. Failure to do so may result in serious personal injury. Pressure gauges must be used to ensure all pressures are at atmospheric level.

For more detailed information on the appropriate materials required for brazing or soldering, please contact the product manufacturer or distributor. For specific applications not covered herein, please contact Danfoss for further information.

System pressure test

Always use an inert gas such as nitrogen for pressure testing. Never use other gasses such as oxygen, dry air or acetylene as these may form

an inflammable mixture. Do not exceed the following pressures:

	CH290 /CH485
Maximum compressor test pressure (low side)	33.3 bar (g)
Maximum compressor test pressure (high side)	48.7 bar (g)
Maximum pressure difference between high and low side of the compressor	37 bar (g)

Pressurize the system on HP side first then LP side to prevent rotation of the scroll. Never let the pressure on LP side exceed the pressure on HP side with more than 5 bar.

On CH models which have an internal non return valve in discharge fitting, we advise to pressurize the system not quicker than 4.8 bar/s to allow pressure equalization between LP and HP side over scroll elements.

Leak detection

Leak detection must be carried out using a mixture of nitrogen and refrigerant or nitrogen and helium, as indicated in the table below. Never use other gasses such as oxygen, dry air

or acetylene as these may form an inflammable mixture. Pressurize the system on HP side first then LP side.

Leak detection with refrigerant	Leak detection with a mass spectrometer
Nitrogen and R410A	Nitrogen and Helium

Note 1: Leak detection with refrigerant may be forbidden in some countries. Check local regulations.
 Note 2: The use of leak detecting additives is not recommended as they may affect the lubricant properties.

Vacuum evacuation and moisture removal

Moisture obstructs the proper functioning of the compressor and the refrigeration system. Air and moisture reduce service life and increase condensing pressure, and cause excessively high discharge temperatures, which can destroy the lubricating properties of the oil. Air and moisture also increase the risk of acid formation, giving rise to copper plating. All these phenomena can cause mechanical and electrical compressor failure.

100 ppm moisture level. The required moisture level in the circuit after vacuum dehydration must be < 100 ppm for systems with a CH.

- Never use the compressor to evacuate the system.
- Connect a vacuum pump to both the LP & HP sides.
- Evacuate the system to a pressure of 500 µm Hg (0.67 mbar) absolute.

For these reasons it's important to perform a vacuum dehydration on the system to remove all residual moisture from the pipe-work after assembly; CH compressors are delivered with <

Do not use a megohm meter nor apply power to the compressor while it's under vacuum as this may cause internal damage.

Filter driers

A properly sized & type of drier is required. Important selection criteria include the driers water content capacity, the system refrigeration capacity and the system refrigerant charge. The drier must be able to reach and maintain a moisture level of 50 ppm end point dryness (EPD).

For servicing of existing installations where acid formation is present the Danfoss DCL (solid core) filter driers containing activated alumina are recommended.

For new installations with CH compressors with polyolester oil, Danfoss recommends using the Danfoss DML (100% molecular sieve) solid core filter drier. Molecular sieve filter driers with loose beads from third party suppliers shall be avoided.

The drier is to be oversized rather than under sized. When selecting a drier, always take into account its capacity (water content capacity), the system refrigeration capacity and the system refrigerant charge.

After burn out, remove & replace the liquid line filter drier and install a Danfoss type DAS burnout drier of the appropriate capacity. Refer to the DAS drier instructions and technical information for correct use of the burnout drier on the liquid line.

Refrigerant charging

For the initial charge the compressor must not run and eventual service valves must be closed. Charge refrigerant as close as possible to the nominal system charge before starting the compressor. This initial charging operation must be done in liquid phase. The best location is on the liquid line between the condenser outlet and the filter drier. Then during commissioning, when needed, a complement of charge can be done in liquid phase: slowly throttling liquid in on the low pressure side as far away as possible from the compressor suction connection while compressor is running. The refrigerant charge quantity must be suitable for both summer and

winter operations. Vacuum or charge from one side can seal the scrolls and result in a non-starting compressor. When servicing, always ensure that LP/ HP pressures are balanced before starting the compressor.

Be sure to follow all government regulations regarding refrigerant reclamation and storage.

For more detailed information see "Recommended refrigerant system charging practice" news bulletin FRCC.EN.050.

Insulation resistance and dielectric strength

Insulation resistance must be higher than 1 megohm when measured with a 500 volt direct current megohm tester.

Each compressor motor is tested at the factory with a high potential voltage (hi-pot) that exceeds the UL requirement both in potential and in duration. Leakage current is less than 0.5 mA.

CH scroll compressors are configured with the pump assembly at the top of the shell, and the motor below. As a result, the motor can be partially immersed in refrigerant and oil. The presence of refrigerant around the motor windings will result in lower resistance

values to ground and higher leakage current readings. Such readings do not indicate a faulty compressor.

In testing insulation resistance, Danfoss recommends that the system be first operated briefly to distribute refrigerant throughout the system. Following this brief operation, retest the compressor for insulation resistance or current leakage.

Never reset a breaker or replace a fuse without first checking for a ground fault (a short circuit to ground). Be alert for sounds of arcing inside the compressor.

Commissioning

The system must be monitored after initial startup for a minimum of 60 minutes to ensure proper operating characteristics such as:

- Proper metering device operation and desired superheat readings
- Suction and discharge pressure are within acceptable levels
- Correct oil level indicating proper oil return

- Low foaming in sight glass and compressor sump temperature 10K above saturation temperature to show that there is no refrigerant migration taking place
- Acceptable cycling rate of compressors, including duration of run times
- Current draw of individual compressors within acceptable values (max operating current)
- No abnormal vibrations and noise.

Oil level checking and top-up

In installations with good oil return and line runs up to 20 m, no additional oil is required. If installation lines exceed 20 m, additional oil may be needed. 1 or 2% of the total system refrigerant charge (in weight) can be used to roughly define the required oil top-up quantity but in any case the oil charge has to be adjusted based on the oil level in the compressor sight glass.

When the compressor is running under stabilised conditions the oil level must be visible in the sight glass.

The presence of foam filling in the sight glass indicates large concentration of refrigerant in the oil and / or presence of liquid returning to the compressor.

The oil level can also be checked a few minutes after the compressor stops.

When the compressor is off, the level in the sight glass can be influenced by the presence of refrigerant in the oil.

Always use original Danfoss POE oil 160SZ from new cans.

Top-up the oil while the compressor is idle. Use the schrader connector or any other accessible connector on the compressor suction line and a suitable pump. See News bulletin "Lubricants filling in instructions for Danfoss Commercial Compressors".

Single pack

Compressor model	Length (mm)	Width (mm)	Height (mm)	Gross weight (kg)
CH290	470	400	698	119
CH485	760	600	900	189

Industrial pack

Compressor model	Nbr*	Length (mm)	Width (mm)	Height (mm)	Gross weight (kg)	Static stacking pallets
CH290	6	1150	965	768	702	2
CH485	4	1150	965	800	737	2

* nbr: number of compressors per pack

Ordering information

Scroll compressors can be ordered in either industrial packs or in single packs. Please use the code numbers from below tables for ordering.

Single usage

CH290	Connections	Mounting feet	Motor protection	Code no.
Single pack	Brazed	Flexible	Module 115-240V *	120H1070
Industrial pack	Brazed	Flexible	Module 115-240V *	120H1071

* Electronic motor protection, module located in terminal box

Parallel usage

Model	Packaging	Connections	Mounting feet	Motor protection	Code no.
CH290	Single	Brazed	Rigid	Module 115-240V	120H1242
CH290	Industrial	Brazed	Rigid	Module 115-240V	120H1243
CH485	Single	Brazed	Rigid	Module 115-240V	120H1245

Application Guidelines Accessories

Solder sleeve adapter set

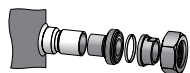

Code n°	Description	Application	Packaging	Pack size
7765028	Rotolock adaptor set (2"1/4 ~ 1"5/8) , (1"3/4 ~ 1"1/8)	CH290	Multipack	6
120Z0504	Rotolock adaptor set (2"1/4 ~ 1"5/8), (1"3/4 ~ 1"3/8)	CH485	Multipack	6

Rotolock adapter



Code n°	Description	Packaging	Pack size
120Z0364	Adaptor (1"3/4 Rotolock - 1"1/8 ODS)	Multipack	10
120Z0432	Adaptor (2"1/4 Rotolock - 1"5/8 ODS)	Multipack	10
120Z0431	Adaptor (1"3/4 Rotolock - 1"3/8 ODS)	Multipack	10

Gaskets



Code n°	Description	Packaging	Pack size
8156132	Gasket, 1"3/4 Models with 1"3/4 rotolock connection	Multipack	10
7956003	Gasket, 1"3/4 Models with 1"3/4 rotolock connection	Industry pack	50
8156133	Gasket, 2"1/4 Models with 2"1/4 rotolock connection	Multipack	10
7956004	Gasket, 2"1/4 Models with 2"1/4 rotolock connection	Industry pack	50

Solder sleeve



Code n°	Description	Packaging	Pack size
8153004	Solder sleeve P02 (1"3/4 Rotolock - 1"1/8 ODF)	Multipack	10
7953005	Solder sleeve P02 (1"3/4 Rotolock - 1"1/8 ODF)	Industry pack	50
8153006	Solder sleeve P03 (2"1/4 Rotolock - 1"5/8 ODF)	Multipack	10
7953006	Solder sleeve P03 (2"1/4 Rotolock - 1"5/8 ODF)	Industry pack	50

Rotolock nut



Code n°	Description	Packaging	Pack size
8153124	Rotolock nut, 1"3/4 Models with 1-3/4" rotolock connection	Multipack	10
7953003	Rotolock nut, 1"3/4 Models with 1-3/4" rotolock connection	Industry pack	50
8153126	Rotolock nut, 2"1/4 Models with 2-1/4" rotolock	Multipack	10
120Z0047	Rotolock nut, 2"1/4 Models with 2-1/4" rotolock	Industry pack	50

Rotolock service valve set



Code n°	Description	Packaging	Pack size
7703383	Valve set, V03 (2"1/4 ~ 1"5/8), V02 (1"3/4 ~ 1"1/8)	Multipack	4

Application Guidelines Accessories

3-phase soft start equipment



Type	Code n°	Description	Application	Packaging	Pack size
MCI 50 CM	037N0401	Electronic soft start kit, MCI 50 C	CH290	Single pack	1
MCD201-055	175G5205	Electronic soft starter MCD201-055-T6-CV1	CH485	Single pack	1

Motor protection modules



Code n°	Description	Application	Packaging	Pack size
120Z0584	Electronic motor protection module, 24 V AC	CH290 & CH485	Single pack	1
120Z0585	Electronic motor protection module, 110-240 V		Single pack	1

Surface sump heaters

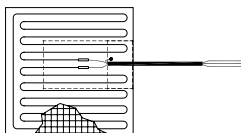

Code n°	Description	Packaging	Pack size
120Z0377	56W 400V surface sump heater + bottom insulation, CE & UL	Multipack	6

Discharge temperature protection



Code n°	Description	Packaging	Pack size
7750009	Discharge thermostat kit	Multipack	10
7973008	Discharge thermostat kit	Industry pack	50

Mounting hardware



Code No	Description	Application	Packaging	Pack Size
8156138	Mounting kit for scroll compressors. Grommets, sleeves, bolts, washers	CH290 & CH485	Single pack	1
7777045	Mounting kit for 1 scroll compressors including 4 hexagon rigid spacer, 4 sleeves, 4 bolts, 4 washers	CH290 & CH485 in parallel installation	Single pack	1
120Z0495	Mounting kit for 1 scroll compressor including 4 triangle rigid spacer, 4 sleeves, 4 bolts, 4 washers	CH290 & CH485 in parallel installation	Single pack	1

Application Guidelines Accessories

Acoustic hoods



Code n°	Description	Packaging	Pack size
120Z0022	Acoustic hood for scroll compressor	Single pack	1
120Z0353	Bottom insulation for scroll compressor	Single pack	1

Lubricant



Code n°	Description	Packaging	Pack size
7754023	POE lubricant, 1 litre can	Single pack	12
120Z0571	POE lubricant, 2.5 litre can	Single pack	4

Miscellaneous



Code n°	Description	Packaging	Pack size
8156019	Sight glass with gaskets (black & white)	Multipack	4
8156129	Gasket for oil sight glass, 1"1/8 (white teflon)	Multipack	10
7956005	Gasket for oil sight glass, 1"1/8 (white teflon)	Multipack	50
8154001	Danfoss Commercial Compressors blue spray paint	Single pack	1

Terminal boxes, covers and T-block connectors



Code No	Description	Application	Packaging	Pack Size
8173021	T block connector 60 x 75 mm	CH290	Multipack	10
8173331	T block connector 80 x 80 mm	CH485	Multipack	10
120Z0458	Terminal box 210 x 190 mm, incl. cover	CH290 & CH485	Single pack	1
120Z0462	Terminal box 210 x 190, incl. cover and module wiring for 258 x 208 and 186 x 198 terminal box replacement	CH290 & CH485	Single pack	1

Previous Version

- Page 16: Suggested wiring diagrams logic

Current Version

- Page 16: Updated wiring diagrams

Danfoss Commercial Compressors

is a worldwide manufacturer of compressors and condensing units for refrigeration and HVAC applications. With a wide range of high quality and innovative products we help your company to find the best possible energy efficient solution that respects the environment and reduces total life cycle costs.

We have 40 years of experience within the development of hermetic compressors which has brought us amongst the global leaders in our business, and positioned us as distinct variable speed technology specialists. Today we operate from engineering and manufacturing facilities spanning across three continents.



Danfoss Scrolls



Danfoss Inverter Scrolls



Danfoss Turbocor Compressors



Danfoss Light Commercial Refrigeration Compressors



Danfoss Maneurop Reciprocating Compressors



Danfoss Optyma Condensing Units

Our products can be found in a variety of applications such as rooftops, chillers, residential air conditioners, heatpumps, coldrooms, supermarkets, milk tank cooling and industrial cooling processes.

<http://cc.danfoss.com>

Danfoss Commercial Compressors, BP 331, 01603 Trévoux Cedex, France | +334 74 00 28 29



Danfoss can accept no responsibility for possible errors in catalogues, brochures and other printed material. Danfoss reserves the right to alter its products without notice. This also applies to products already on order provided that such alterations can be made without subsequential changes being necessary in specifications already agreed. All trademarks in this material are property of the respective companies. Danfoss and the Danfoss logotype are trademarks of Danfoss A/S. All rights reserved.