

ENGINEERING
TOMORROW



Catalogue

Hermetic Compressors For **DC Voltage**

R134a | R404A | R507 | R290 | R600a

12/24/48

The widest range
of direct current
compressors

Part 1

BD Compressors - Product range



Part I	
BD Compressors – Product Range.....	3
BD Compressors – Electronics Units & Applications.....	4-5
Code Numbers BD35/50/80F BD150F BD250GH.2 BD35K BD80CN BD100CN.....	6-7
Code Numbers BD250GH.2 BD350GH with 101N07xx Series Controllers.....	8-9
Code Numbers BD350GH BD220CL with 101N08xx Series Controllers.....	10-11
Code Numbers BD1.4F-AUTO BD1.4F-VSD BD1.4F-FSD.....	12-13
Part II	
Application Examples.....	14
Comfort Cooling in Trucks.....	16-17
Cooling in Maritime Appliances.....	18-19
Cooling in Recreational Vehicles (RV).....	20-21
Refrigerators in Trucks.....	22-23
Cooling in Medi Boxes.....	24-25
Solar Assisted Cooling.....	26-27
Cooling in Portable Cooling Boxes.....	28-29
Control your Cold Chain - BD Van Boxes.....	30-31
Telecom Cooling - Increase Battery Lifetime.....	32-33
Mobile Refrigeration in Cars.....	34-35
Mobile Refrigeration in Buses.....	36-37
Part III	
DC Compressors Basics.....	38
Secop compressors produced for Danfoss Variable Speed for Direct Current Compressors.....	39-45
Electronic Units - Technical Data.....	46-47
Electronic Units - Housings.....	48-49
Electronic Units - Features.....	50-59
Precondition for Long Operating Life.....	60
Design Limits.....	61
Moisture and Impurities / Filter Drier Selection.....	62
Condition at Delivery / Warnings.....	63
Max. Refrigerant Charge.....	64
Conversions.....	65
Mounting the Compressor.....	66
Mounting Accessories.....	67
Shipment Positions.....	68
Appendix	
Data Sheets.....	70-123



TOOL4COOL® Software
 Tool4Cool® is a unique PC software tool that enables you to precisely configure your Secop compressors produced for Danfoss to your cooling systems.
 Via microprocessor-based controllers, Tool4Cool® gives you easy access to all parameters. These can be changed, monitored, downloaded or uploaded to get the optimum performance out of your cooling system.
 Please visit www.secop.com/tool4cool.html for more information.

Hermetic Compressors for DC Voltage

Modern comfort is brought into life when leaving home. As people go mobile, so does food. The excellent performance of the BD series safeguards food preservation. With our outstanding DC compressors for cars, vans, boats, trucks, etc., Secop compressors produced for Danfoss has transcended the barriers for mobile refrigeration.



**** Please refer to the individual compressor data sheets for the complete application range.

Compressors R134a R404A/R507 * R600a **, R290 ***	Capacity [W] at max. speed **** EN12900 Household/CECOMAF ASHRAE Evaporating temperature [°C]													
	-40	-35	-30	-25	-23.3	-20	-15	-10	-5	0	5	7.2	10	15
	BD35F /-B /-HD			26 32	36 44	40 50	51 62	70 86	94 115	122 150				
BD50F			37 45	52 64	58 72	71 88	95 117	123 152	157 194					
BD80F			55 68	78 96	87 107	105 130	138 170	176 218	221 274					
BD250GH.2				61 76	69 86	87 108	119 148	156 194	200 248	251 311	308 383	336 418	373 464	446 556
BD250GH.2 (48V)				64 80	73 91	91 113	124 153	162 201	208 257	261 323	322 400	352 437	392 488	472 589
BD350GH (12V)				126 156	139 173	169 209	220 273	282 349	355 440	440 546	540 670	588 731	654 814	786 979
BD350GH (24V)				126 156	139 173	169 209	220 273	282 349	355 440	440 546	540 670	588 731	654 814	786 979
BD350GH (48V)				121 150	135 167	164 203	216 267	277 343	350 434	436 540	535 664	584 725	650 808	781 973
BD350GH Twin (12V)				251 312	279 346	337 418	440 546	564 698	710 880	880 1092	1080 1340	1176 1462	1308 1628	1572 1958
BD350GH Twin (24V)				252 312	278 346	338 418	440 546	564 698	710 880	880 1092	1080 1340	1176 1462	1308 1628	1572 1958
BD220CL *	83 96	121 140	166 193	220 255	240 279	283 328	355 413	439 511	535 624					
BD35K **			25 30	36 44	41 49	49 60	65 79	84 102	106 129					
BD80CN ***	31 35	45 51	62 69	82 91	90 100	105 118	133 148	164 184						
BD100CN ***	45 50	62 70	83 93	108 121	117 131	137 153	170 190	209 233						
BD1.4F-VSD /-HD			12 15	23 29	27 34	36 45	52 65	71 88	92 114	116 144	144 179	158 197	178 222	218 272
BD1.4F-FSD			5 6	13 17	16 21	23 29	35 44	49 62	66 82	85 106				
BD1.4F-AUTO				14 18	18 22	24 31	36 45	50 62	66 83	86 106	108 134			

Compressors R134a R404A/R507 * R600a **, R290 ***	Code numbers	Power consumption [W] at max. speed **** Evaporating temperature [°C]													
		-40	-35	-30	-25	-23.3	-20	-15	-10	-5	0	5	7.2	10	15
		BD35F /-B /-HD	101Z0200 /0204 /0205 /0206			36	43	45	51	60	69	79			
BD50F	101Z1220 /0203			47	59	63	71	83	95	108					
BD80F	101Z0280			69	87	93.0	105	123	144	168					
BD250GH.2	101Z0406				68	72	82	95	108	122	138	156	165	177	202
BD250GH.2 (48V)	101Z0405				72	77	85	99	113	128	143	160	167	177	196
BD350GH (12V)	102Z3015				140	149	168	197	228	259	292	325	340	358	391
BD350GH (24V)	102Z3016				122	129	144	169	194	221	248	276	288	303	330
BD350GH (48V)	102Z3031				131	139	155	181	208	236	265	294	307	323	352
BD350GH Twin (12V)	102Z3018				280	298	336	394	456	518	584	650	680	716	782
BD350GH Twin (24V)	102Z3017				244	258	288	338	388	442	496	552	576	606	660
BD220CL *	102Z3020	121	147	173	200	209	227	255	284	314					
BD35K **	101Z0211			35	43	45	50	56	63	70					
BD80CN ***	101Z0403	47	55	63	72	75	81	89	97						
BD100CN ***	101Z0401	57	69	81	93	96	104	115	125						
BD1.4F-VSD /-HD	109Z0200 /0202 /0250 /0251			27	34	36	41	48	55	61	68	76	79	83	90
BD1.4F-FSD	109Z0305			16	23	25	29	35	40	44	49				
BD1.4F-AUTO	109Z0102			26	28	30	35	40	45	50	56				

BD Compressors

Electronic units & Applications

Compressors R134a R404A/R507 * R600a ** R290 ***	Code numbers	Electronic units (voltages & code numbers)													
		Standard 12-24V DC 101N0210	EMI 12-24V DC 101N0220	High Start 12-24V DC 101N0230	High Speed 12-24V DC 101N0290	AEO/EMI 12-24V DC 101N0320	AEO High Start 12-24V DC 101N0330	Solar 10-30V DC 101N0400	Solar 20-45V DC 101N0410	AC/DC converter 12-24V DC & 100-240V AC 101N0500	Automotive 12-24V DC 101N0600 101N0630	101N8xxx 12V DC 101N0820+0800 (alt.: 101N0830)	101N8xxx 24V DC 101N0820+0810	101N07xxx 24V DC 101N0715	Telecom 48V DC 101N0720
BD35F	101Z0200	✓	✓			✓		✓	✓	✓	✓				
BD35F (inch con.)	101Z0204	✓	✓			✓		✓	✓	✓	✓				
BD35F-B	101Z0205	✓	✓			✓				✓	✓				
BD35F-HD	101Z0206	✓													
BD50F	101Z1220	✓	✓	✓		✓	✓			✓					
BD50F (inch con.)	101Z0203	✓	✓	✓		✓	✓			✓					
BD80F	101Z0280				✓										
BD250GH.2	101Z0406				✓										
BD250GH.2 (48V)	101Z0405														✓
BD350GH (12V)	102Z3015										✓+✓				
BD350GH (24V)	102Z3016											✓+✓	✓		
BD350GH (48V)	102Z3031													✓	
BD350GH Twin (12V)	102Z3018										✓+✓✓				
BD350GH Twin (24V)	102Z3017											✓+✓✓	✓✓		
BD220CL *	102Z3020										✓+✓				
BD35K **	101Z0211	✓	✓					✓	✓						
BD80CN ***	101Z0403			✓			✓								
BD100CN ***	101Z0401				✓										
TOOL4COOL® applicable											✓		✓	✓	✓

Compressors R134a	Code numbers	Electronic units (voltages & code numbers)					Applications	Compressors																
		Variable Speed (VSD) 12-24V DC 101N2100	Fixed Speed (FSD) 12-24V DC 101N2600	VSD w/ AC/DC converter 12-24V DC & 100-240V AC 101N5100	FSD w/ AC/DC converter 12-24V DC & 100-240V AC 101N5200	Automotive 12V DC 101N1010		BD1.4F-AUTO	BD1.4F-VSD	BD1.4F-VSD-HD	BD1.4F-FSD	BD35F	BD35F-B	BD35F-HD	BD35K	BD50F	BD80F	BD80CN	BD100CN	BD150F	BD250GH	BD350GH	BD220CL	
BD1.4F-AUTO	109Z0102					✓	Truck refrigerators	✓	✓	✓	✓	✓	✓	✓	✓	✓								
BD1.4F-FSD	109Z0305		✓		✓		Boat refrigerators	✓		✓				✓	✓									
BD1.4F-VSD	109Z0200	✓		✓			Bus refrigerators	✓		✓	✓													
BD1.4F-VSD-HD	109Z0250	✓					Portable boxes	✓		✓	✓			✓	✓									
BD1.4F-VSD (inch connectors)	109Z0202	✓		✓			Car minibars (high end)	✓	✓		✓													
BD1.4F-VSD-HD (inch connectors)	109Z0251	✓					Car minibars (SUV, MPV)	✓		✓														
TOOL4COOL® applicable		✓	✓	✓	✓	✓	Spot cooling (e.g. trucks)														✓	✓		
							Van boxes							✓	✓			✓	✓		✓	✓	✓	✓
							Battery cooling														✓	✓		
							Solar cabinets				✓			✓	✓		✓	✓						



BD1.4F-AUTO and BD1.4F-VSD/-FSD

R134a, -30°C, +5 and +15 / 0°C evap. temp.
In-car cabinets and all mobile applications for portable boxes, boats, trucks etc.,
14-108 W and 7-218 W / 5-85 W cooling capacity*.



BD80/100CN

R290, -40°C, -10°C evap. temp.
Stationary freezer application (not approved for vehicles), solar-powered systems, ice cream boxes up to 200 l,
20-164 W / 31-209 W cooling capacity*.



BD35K

R600a, -30°C, +10°C evap. temp.
Stationary application, solar-powered vaccine coolers etc., 100-200 l coolers,
13-128 W cooling capacity*.



BD150F

R134a, -35°C, -10°C evap. temp.
The BD150F compressor is intended especially for the use in mobile applications, e.g. in vans and small trucks,
47-345 W cooling capacity*.



BD250GH.2

R134a, -25°C, +15°C evap. temp.
Designed for cabin cooling in trucks during nighttime, very silent operation,
32-446 W cooling capacity*.



BD35F/50F Multivoltage

R134a, -30°C, +10°C evap. temp.
All mobile applications for portable boxes, boats, trucks etc., can be powered with AC and DC,
85-240 V AC 50/60 Hz, 12-24 V DC, automatic selection of AC when available,
15-152 / 20-191 W cooling capacity*.



BD35F/50F/80F Basic

R134a, -30°C, +10°C evap. temp.
All mobile applications for portable boxes, boats, trucks etc.,
15-152 W / 20-191 W / 35-221 W cooling capacity*.



BD350GH Single or Twin

Configuration
R134a, -25°C, +15°C evap. temp.
Tailored for spotcooling systems in sleeping compartments in trucks, caravans, golf buggies etc.,
85-786 W single cooling capacity*.

* CECOMAF conditions

Code numbers

BD35/50/80F | BD150F | BD250GH.2

BD35K | BD80CN | BD100CN



Hermetic Compressors for DC Voltage

Compressors	Code number	Description
BD35F	101Z0200	standard compressor, mm tube connectors
BD35F inch	101Z0204	same as 101Z0200, inch tube connectors
BD35F-B	101Z0205	optimized for rough vehicle motions (especially in buses), mm tube connectors
BD35F-HD	101Z0206	heavy duty version which can handle extreme vibrations, mm tube connectors
BD35K (R600a)	101Z0211	for stationary use only, mainly solar applications, mm tube connectors
BD50F	101Z1220	standard compressor, mm tube connectors
BD50F inch	101Z0203	same as 101Z1220, inch tube connectors
BD80F	101Z0280	standard compressor, mm tube connectors
BD150F	102G4784	standard compressor, mm tube connectors, TL - based, 12/24 V DC with inverter
BD250GH.2	101Z0406	mm tube connectors, HBP compressor
BD80CN (R290)	101Z0403	mm tube connectors, LBP compressor
BD100CN (R290)	101Z0401	mm tube connectors, LBP compressor

Electronic Unit Single Pack	Code number	Description
Standard	101N0210	for BD35F/BD50F, speed setting, battery protection
EMI	101N0220	for BD35F/BD50F, radiation extra shielded, speed setting, battery protection
AEO EMI	101N0320	for BD35F/BD50F, Adaptive Energy Optimization, radiation extra shielded, speed setting, battery protection
AEO high start	101N0330	for BD50F/BD80CN, Adaptive Energy Optimization, speed setting, battery protection, extra high start performance
Solar 10-30 V DC	101N0400	for BD35F/BD35K, optimized for direct solar panel operation, speed setting
Solar 20-45 V DC	101N0410	for BD35F/BD35K, optimized for direct solar panel operation, speed setting
AC/DC converter	101N0500	for BD35F/BD50F, speed setting, battery protection, integrated AC/DC converter
High start	101N0230	for BD50F/BD80CN only, extra high start performance, speed setting, battery protection
High speed	101N0290	for BD80F/BD250GH.2/etc., Adaptive Energy Optimization, speed setting, battery protection
Automotive	101N0600	for BD35F, CISPR 25 class 5 approved, speed setting, battery protection, lamp output
Automotive (harness connector)	101N0630	for BD35F, CISPR 25 class 5 approved, speed setting, battery protection, lamp output
Remote kit with cable	105N9100	bracket, cover, 750 mm cable with two plugs
Remote kit without cable	105N9210	bracket, cover, two plugs
AC line cord (UL approved)	105N9520	for electronic unit with AC/DC converter
AC line cord (VDE approved)	105N9530	for electronic unit with AC/DC converter

Electronic Unit I - Pack	Code number	Description
Standard	101N0211	for BD35F/BD50F, speed setting, battery protection, 30 pcs.
EMI	101N0221	for BD35F/BD50F, radiation extra shielded, speed setting, battery protection, 30 pcs.
AEO EMI	101N0321	for BD35F/BD50F, Adaptive Energy Opt., radiation extra shielded, speed setting, battery protection, 30 pcs.
AEO high start	101N0331	for BD50F/BD80CN, Adaptive Energy Optimization, speed setting, battery protection, extra high start performance, 30 pcs.
Solar 10-30 V DC	101N0401	for BD35F/BD35K, optimized for direct solar panel operation, speed setting, 30 pcs.
Solar 20-45 V DC	101N0411	for BD35F/BD35K, optimized for direct solar panel operation, speed setting, 30 pcs.
AC/DC converter	101N0501	for BD35F/BD50F, speed setting, battery protection, integrated AC/DC converter, 36 pcs.
High start	101N0231	for BD50F/BD80CN, extra high start performance, speed setting, battery protection, 30 pcs.
High speed	101N0291	for BD80F/BD250GH.2/etc., Adaptive Energy Optimization, speed setting, battery protection, 28 pcs.
Automotive	101N0601	for BD35F, CISPR 25 class 5 approved, speed setting, battery protection, lamp output, 30 pcs.
Automotive (harness connector)	101N0631	for BD35F, CISPR 25 class 5 approved, speed setting, battery protection, lamp output, 30 pcs.
BD150F	105N4220	for BD150F, Adaptive Energy Optimization, speed setting, 20 pcs.
Remote kit without cable	105N9200	bracket, cover and two plugs, 200 pcs.
AC line cord (UL approved)	105N9521	for electronic unit with AC/DC converter, 80 pcs.
AC line cord (VDE approved)	105N9531	for electronic unit with AC/DC converter, 80 pcs.

Code numbers

BD250GH.2 | BD350GH

with 101N07xx series controllers



Hermetic Compressors for DC Voltage

	Item	Code number	Description
Compressors	BD250GH.2 48 V DC supply	101Z0405	for telecommunication applications (battery cooling)
	BD350GH 24 V DC supply	102Z3016	for cooling and comfort cooling in trucks and vans
	BD350GH 48 V DC supply	101Z3031	for telecommunication applications (battery cooling)
	BD350/350GH 24 V DC supply - twin compressor	102Z3017	for cooling and comfort cooling in trucks and vans
Single-Pack	Electronic unit 24 V DC	101N0715	for BD350GH (24 V), 40/60 W fan output, ECO function
	Electronic unit 48 V DC	101N0732	for BD250GH.2 (48 V), 60 W fan output, ECO function
	Electronic unit 48 V DC	101N0720	for BD350GH (48 V), 60 W fan output, ECO function
	48 V DC line cord, 900 mm, 6 mm ²	105N9542	accessories
	48 V DC line cord, 2000 mm, 6 mm ²	105N9540	accessories
	48 V DC line cord, 5000 mm, 6 mm ²	105N9538	accessories
	Temperature sensor, 470 mm, spade connectors	105N9612	accessories
	Temperature sensor, 1000 mm, spade connectors	105N9614	accessories
Industrial-Pack (1-Pack)	Electronic unit 24 V DC	101N0714	for BD350GH (24 V), 36 pcs.
	Electronic unit 48 V DC	101N0733	for BD250GH.2 (48 V), 36 pcs.
	Electronic unit 48 V DC	101N0721	for BD350GH (48 V), 36 pcs.
	Communication cable, 1500 mm, AMP connector	105N9545	100 pcs.
	Communication cable, 3000 mm, AMP connector	105N9547	50 pcs.
	48 V DC line cord, 900 mm, 6 mm ²	105N9543	36 pcs.
	48 V DC line cord, 2000 mm, 6 mm ²	105N9541	36 pcs.
	48 V DC line cord, 5000 mm, 6 mm ²	105N9539	36 pcs.
	Temperature sensor, 470 mm, spade connectors	105N9613	200 pcs.
	Temperature sensor, 1000 mm, spade connectors	105N9615	100 pcs.
	Temperature sensor, 1500 mm, spade connectors	105N9617	100 pcs.
Software	Tool4Cool® LabEdition	free of charge	download from: www.secop.com/tool4cool.html

Code numbers

BD350GH | BD220CL

with 101N08xx series controllers



Hermetic Compressors for DC Voltage

	Item	Code number	Description
Compressors	BD350GH 12 V DC supply	102Z3015	for cooling and comfort cooling in trucks and vans
	BD350/350GH 12 V DC supply - twin compressor	102Z3018	for cooling and comfort cooling in trucks and vans
	BD350GH 24 V DC supply	102Z3016	for cooling and comfort cooling in trucks and vans
	BD350/350GH 24 V DC supply - twin compressor	102Z3017	for cooling and comfort cooling in trucks and vans
	BD220CL 12 V DC supply	102Z3020	for mobile refrigeration units (boxes, containers, trolleys)
Single-Pack	Electronic unit (compressor module) 12 V DC	101N0800	electronic module (to be used together with 101N0820)
	Electronic unit (compressor module) 24 V DC	101N0810	electronic module (to be used together with 101N0820)
	Electronic unit (application module) 12 & 24 V DC	101N0820	electronic module (to be used together with 101N800/810)
	Electronic unit (single solution) 12 V DC	101N0830	electronic unit (no fan control)
	Temperature sensor, 470 mm, spade connectors	105N9612	accessories
	Temperature sensor, 1000 mm, spade connectors	105N9614	accessories
	Temperature sensor, 1500 mm, spade connectors	105N9616	accessories
	Secop One Wire/LIN gateway with cables & driver	105N9501	accessories
	One Wire/LIN gateway communication cable	105N9524	accessories (for 101N8xxx series)
	Secop Bluetooth® gateway with power supply	105N9502	accessories
	Bluetooth® gateway communication cable	105N9525	accessories
Industrial-Pack (I-Pack)	Electronic unit (compressor module) 12 V DC	101N0801	30 pcs.
	Electronic unit (compressor module) 24 V DC	101N0811	30 pcs.
	Electronic unit (application module) 12 & 24 V DC	101N0821	24 pcs.
	Electronic unit (single solution) 12 V DC	101N0831	30 pcs.
	Compressor communication cable assembly 1500 mm	105N9553	80 pcs.
	Compressor communication cable assembly 3000 mm	105N9554	45 pcs.
	Twin compressor communication cable assembly 800 mm	105N9561	65 pcs.
	Twin compressor communication cable assembly 1500 mm	105N9555	65 pcs.
	Twin compressor communication cable assembly 3000 mm	105N9556	40 pcs.
	Temperature sensor, 470 mm, spade connectors	105N9613	200 pcs.
	Temperature sensor, 1000 mm, spade connectors	105N9615	100 pcs.
	Temperature sensor, 1500 mm, spade connectors	105N9617	100 pcs.
	Display cable assembly without fuse 1500 mm	105N9557	65 pcs.
	Display cable assembly without fuse 3000 mm	105N9558	35 pcs.
Software	Tool4Cool® LabEdition	free of charge	download from: www.secop.com/tool4cool.html

Code numbers

BD1.4F-AUTO | BD1.4F-VSD | BD1.4F-VSD



Hermetic Compressors for DC Voltage

Compressors	Code number	Description
BD1.4F-AUTO mm	109Z0102	automotive compressor, mm tube connectors
BD1.4F-VSD mm	109Z0200	variable speed drive compressor, mm tube connectors
BD1.4F-VSD inch	109Z0202	same as 109Z0200, inch tube connectors
BD1.4F-VSD-HD mm	109Z0250	variable speed drive compressor (heavy duty), mm tube connectors, for trucks and buses
BD1.4F-VSD-HD inch	109Z0251	same as 109Z0250, inch tube connectors, for trucks and buses
BD1.4F-FSD	109Z0305	fixed speed drive compressor, mm tube connectors, for portable boxes

Electronic Single Pack	Code number	Description
Automotive	101N1010	for BD1.4F-AUTO, battery protection, 12 V, fixed speed (3,000 rpm)
Variable Speed (VSD)	101N2100	for BD1.4F-VSD/-HD, speed setting, battery protection, 12 - 24 V, variable speed (2,000 - 4,000 rpm)
Fixed Speed (FSD)	101N2600	for BD1.4F-FSD, battery protection, 12 - 24 V, fixed speed (3,000 rpm)
VSD with AC/DC converter	101N5100	for BD1.4F-VSD/-HD, speed setting, battery protection, 12 - 24 V DC & 100 - 240 V AC
FSD with AC/DC converter	101N5200	for BD1.4F-FSD, battery protection, 12 - 24 V DC & 100 - 240 V AC

Electronic I - Pack	Code number	Description
Automotive	101N1011	for BD1.4F-AUTO, battery protection, 30 pcs.
Variable Speed (VSD)	101N2101	for BD1.4F-VSD/-HD, speed setting, battery protection, 30 pcs.
Fixed Speed (FSD)	101N2601	for BD1.4F-FSD, battery protection, 30 pcs.
VSD with AC/DC converter	101N5101	for BD1.4F-VSD/-HD, speed setting, battery protection, 24 pcs.
FSD with AC/DC converter	101N5201	for BD1.4F-FSD, battery protection, 24 pcs.

Software	Comment	Location
Tool4Cool® LabEdition	free of charge	download from: www.secop.com/tool4cool.html

Part 2

Application examples



BD compressors bring comfort at work and leisure. The direct current compressors BD35F/50F/80F for 12/24 V DC power supply can be used in mobile refrigerators and freezers with refrigerant R134a.

The BD250GH.2 and the BD350GH compressors in 12/24 or 48 V DC versions are R134a HBP compressors used for mobile spot cooling systems or telecommunication cooling.

BD35K (R600a) and BD80/100CN (R290) compressors can be used with HFC-free refrigerants in stationary applications.

All compressors are equipped with an electronic unit with built-in thermal protection which also protects against destructive battery discharge. The advanced micro controller technology enables new functions like: electronic thermostat, fan speed, ECO function and software main switch.

Second to none – even cooling without power supply

Thanks to an extensive voltage rate the BD compressors are ideal for solar energy supply. The exceptionally low starting current eliminates the need for current batteries if an ice bank is used for energy storage. When storing the sun energy in ice packs the cabinet can be kept at desired temperatures both night and day.

This feature offers numerous uses in areas without power supply like storage and transportation of drugs, ice cream stands in holiday resorts, food preservation under off road conditions, refrigerators in boats to name only a few.



BD1.4F-VSD (Variable Speed Drive)

The new BD1.4F-VSD from Secop compressors produced for Danfoss is 60% smaller than previous models and weighs in at only 2.3 kilos. Perfect for 10-20 litre in car/ van/boat cabinets or portable boxes that need to fit into tight spaces without compromising storage space.

Specially designed for maximum efficiency and reliability this powerhouse of a compressor makes it easier than ever to provide leading class mobile refrigerators.

Enabling the variable speed function increases the system's COP. Low energy consumption is good for car/ boat/ van batteries – as well as the environment. The optimized, low noise motor ensures outstanding performance when you want to provide that extra degree of luxury on the move.

The electronic thermostat provides an accurate temperature while the failure detection allows a fast fault diagnosis. The computer interface makes it easier for customization.

BD35F-HD & BD1.4F-VSD-HD (Heavy Duty)

BD35F-HD and BD1.4F-VSD-HD are new versions which can handle extreme vibrations.

BD35F-B (Bus-optimized)

The BD35F-B is a special version optimized for rough vehicle motions, especially in buses.

BD1.4F-FSD (Fixed Speed Drive)

The new BD1.4F-FSD is a cost-optimized variant of our BD-Micro series which is perfect for portable boxes.

Hermetic Compressors for DC Voltage

Secop compressors produced for Danfoss mean: extraordinary performance at minimum power consumption, superbly silent running, reliable operation even when tilted up to 30 degrees, problem-free operation at 12/24/48 volts and more than 35 years' of experience in mobile refrigeration. Transport stable, speed/capacity stable, multifunctional electronic, silent, high COP and compact design.



Comfort cooling in trucks

BD250GH.2 • BD350GH



In the USA, Australia, Asia, South America and Europe many of the heavy trucks are equipped with sleeping compartments. The sleeping compartment give the driver the opportunity to respond to spontaneous transport tasks, and to plan his own working days.

To ensure a good night sleep it is important to keep the temperature and the humidity in the cabin on a comfortable level also during night time when the engine is shut off, and the air conditioning system is not running. Many states and countries have abandoned idle cooling, meaning the diesel engine is not allowed to run when the truck is parked.

To keep a comfortable temperature during the hot summer nights a small DC driven comfort cooler system could be the solution. It cools down the cabin and at the same time it reduces the humidity to a comfortable level.

BD250GH.2 and BD350GH compressors are tailored for the driving workplaces.

They are universal for 12 V and 24 V DC power supply. Besides they are unsurpassed to tolerate changeable climatic conditions and vibrations under harsh road conditions all over the world.

The compressors cover a capacity range from 180 W to 850 W at $T_e + 15^\circ\text{C}$. Especially designed for high back pressure applications.

The compressors are controlled by an electronic unit including protection against overload and destructive battery discharge. The unit also features an internal voltage recording as well as calibration to the applied voltage (compressor monitoring) plus many other smart features in order to save energy and maximize performance.

Features	Benefits
• Silent operation	• The driver can sleep without being disturbed by a noisy compressor.
• High efficiency. Low current consumption	• Energy saving. Less batteries needed to cool over night.
• Variable speed / capacity	• Energy savings. Adapt speed to cooling requirement.
• Direct 12 / 24 V DC power supply	• Same compressor can be used globally. One product covers the world.
• Modbus communication connection	• Customers can make their own control box including control of the BD compressor.
• Electronic thermostat	• Cost savings. No extra thermostat needed.
• Alarm & event logs	• Less components and failure modes.
• Fan speed control 40 - 100%. Start / stop delays	• Makes identification of errors fast and easy servicing.
• Advanced battery protection function	• Reduced service costs.
• No APU necessary	• Less noise during night.
• Transport stable	• Less components, less costs, less wiring, less installation costs.
	• Safety. The battery will never be drained.
	• Safe start of the truck every time.
	• Runs directly on battery. No additional cost for an Auxillary Power Unit.
	• Reduced cost and failure modes.
	• Designed to resist vibrations, shocks and bumping roads.
	• Design lifetime 10 years. Reduced service costs.

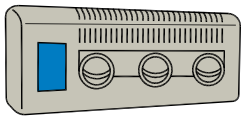

Secop
28.10

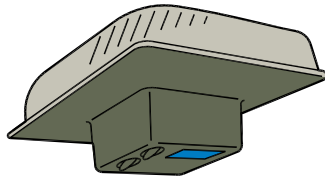
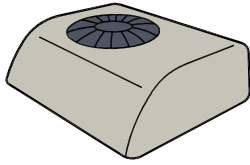

Secop
26.10

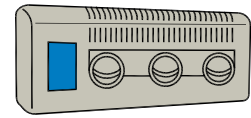

Secop
27.10

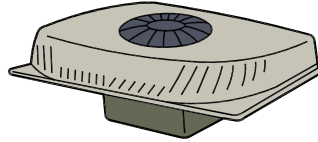
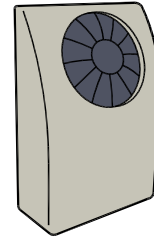

Cooling in maritime appliances

BD1.4F-VSD • BD35F • BD50F • BD80F



The BD compressor series is specially designed for refrigeration in boat applications. A sturdy design enables it to resist vibrations, hard impacts and heavy seas.

The compressors cover a capacity range from 20 to 180 Watt. Low and medium back pressure applications. Refrigerator sizes up to 180 liters and freezers up to 90 liters.

It is possible to adjust the capacity of the compressor manually. A special version of the electronic unit will adapt the capacity of the compressor automatically (AEO) to the actual load on the refrigeration system. The algorithm will adjust the speed of the compressor so that a running time of approximately 30 minutes is achieved. This is the most energy efficient way to operate the compressor. The BD.14F-VSD offers an ECO function which adapts the speed of the compressor to an optimum.

Furthermore these functions will protect the compressor from short cycling in low load situations and it will also reduce the number of starts and thereby protect the battery from being drained.

An optional LED (diode) will flash and the following faults will be indicated by means of a flash pattern: low battery voltage, fan overload, minimum speed exceeded, thermal cut out, motor start error.

The new BD1.4F-VSD has additional features such as fan speed control, built in electronic thermostat, communication interface which makes programming of the controller easy, without resistors and extra wiring.

The electronic unit provides protection against electro magnetic interference (EMI) which will allow communication and navigation equipment to work unproblematically without any disturbance.

Features	Benefits
• Silent operation	• No compressor noise during night when sleeping next to the refrigerator in the boat.
• High efficiency. Low current consumption	• Energy saving. Operates on a smaller battery.
• Variable speed / capacity	• Energy savings. Adapt speed to cooling requirement.
• Direct 12 / 24 V DC powersupply	• Same compressor can be used globally. One product covers the world.
• Modbus communication connection	• Possible to make customized settings and fast programming on the production line.
• Electronic thermostat	• Cost savings. No extra thermostat needed.
• Alarm & event logs	• Less components and failure modes.
• Fan speed control 40 - 100%.	• Make identification of errors fast and easy servicing.
• Start / stop delays	• Reduced service costs.
• Advanced battery protection function	• Less noise during night.
• AC/DC module available as option	• Less components, less costs, less wiring, less installation costs.
• Transport stable	• Safety. The battery will never be drained to a destructive level.
	• During stay in a port the refrigerator can be powered by shore power (100 - 240 V AC, 50/60 Hz).
	• Designed to resist conditions on the sea such as vibrations, shocks and harsh weather. Design lifetime 10 year. Reduced service costs.

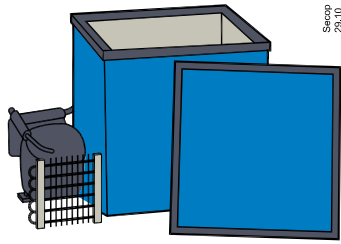

Secop
25,10



Secop
31,10

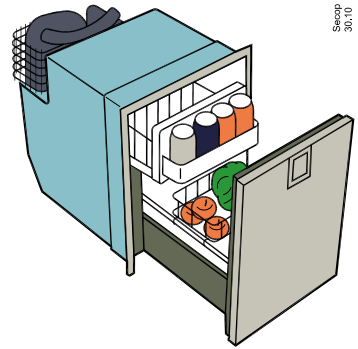

Secop
30,10



Cooling in recreational vehicles (RV)

BD1.4F-VSD • BD35F • BD50F • BD80F



Everybody wants to bring modern comfort with them when going on holiday or a weekend tour. With the BD compressors it is possible to go on vacation in recreational vehicles all over the world and to bring along a refrigerator and a freezer – even in "off grid" places without power supply. The compressors from Secop compressors produced for Danfoss are universal for 12 and 24 V DC power supply and can be used in recreational vehicles like luxury coaches, diesel motor homes, mini motor homes, travel trailers and fifth wheels, truck campers, etc. They are unsurpassed to tolerate changeable climatic conditions and vibrations under harsh road conditions.

The BD1.4F-VSD, BD35F, BD50F and BD80F compressors cover a capacity range from 20 to 180 W. Low and medium back pressure applications. Refrigerator sizes up to 180 liters and freezers up to 90 liters.

A special version of the electronic unit will adapt the capacity of the compressor automatically (AEO) to the actual load on the refrigeration system. The algorithm will adjust the speed of the compressor so that a running time of approximately 30 minutes is achieved. This is the most energy efficient way to operate the compressor. The BD.14F-VSD offers an ECO function which adapts the speed of the compressor to an optimum. It has additional features such as fan speed control, built in electronic thermostat, communication interface which makes programming of the controller easy, without resistors and extra wiring.

The compressors are controlled by an electronic unit including protection against overload and destructive battery discharge. The unit also features an internal voltage recording as well as calibration to the applied voltage (compressor monitoring).

Features	Benefits
<ul style="list-style-type: none"> • Silent operation • High efficiency. • Low current consumption • Variable speed / capacity • Direct 12 / 24 V DC power supply 	<ul style="list-style-type: none"> • No compressor noise during night when sleeping next to the refrigerator in the RV. • Energy saving. Operates on a smaller battery. Three times less energy consumption compared to absorption, and fast pull down. • Energy savings. Adapt speed to cooling requirement.
<ul style="list-style-type: none"> • Modbus communication connection • Electronic thermostat 	<ul style="list-style-type: none"> • Same compressor can be used globally. One product covers the world. • Possible to make customized settings and fast programming on the production line. • Cost savings. No extra thermostat needed. • Less components and failure modes. • Make identification of errors fast and easy servicing.
<ul style="list-style-type: none"> • Alarm & event logs • Fan speed control 40 - 100%. • Start / stop delays • Advanced battery protection function 	<ul style="list-style-type: none"> • Reduced service costs. • Less noise during night. • Less components, less costs, less wiring, less installation costs. • Safety. The battery will never be drained to a destructive level.
<ul style="list-style-type: none"> • Transport stable • AC/DC module available as option 	<ul style="list-style-type: none"> • Designed to resist vibrations, shocks, mountain terrain and bumping roads. Design lifetime 10 year. Reduced service costs. • During stay in a camp site the refrigerator can be powered by mains power (100 - 240 V AC, 50/60 Hz).

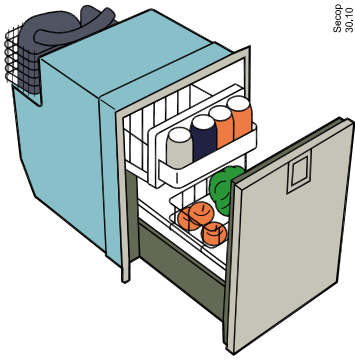

Refrigerators in trucks

BD1.4F-VSD-HD • BD1.4F-VSD • BD35F-HD • BD35F • BD50F



Most truck drivers are on the road for many days at a time. To keep their food and beverages cold they need refrigerators that can be built into the cab.

The BD compressors are tailored for the driving workplaces. BD35F-HD and BD1.4F-VSD-HD are special versions designed to meet even harder road conditions where the refrigerator is mounted on the chassis of the truck. They are universal for 12 and 24 V DC power supply.

Besides this they are unsurpassed in their ability to tolerate changeable climatic conditions and vibrations under harsh road conditions all over the world.

BD35F and BD50F compressors can be used for both refrigerators and freezers.

The compressors cover a capacity range from 20 to 180 W. Low, medium and high back pressure applications. Refrigerator sizes up to 80 liters incl. freezer compartment.

The compressors are controlled by an electronic unit including protection against overload and destructive battery discharge. The unit also features an internal voltage recording as well as calibration to the applied voltage (compressor monitoring).

The new BD1.4F-VSD has additional features such as fan speed control, built in electronic thermostat, communication interface which makes programming of the controller easy, without resistors and extra wiring.

Features	Benefits
• Silent operation	• The driver can sleep without being disturbed by a noisy compressor.
• High efficiency.	• Energy saving. Less batteries needed to cool over night.
• Low current consumption	• Energy savings. Adapt speed to cooling requirement.
• Variable speed / capacity	• Same compressor can be used globally. One product covers the world.
• Direct 12 / 24 V DC power supply	• Customers can make their own control box including control of the BD compressor.
• Modbus communication connection	• Cost savings.
• Electronic thermostat	• No extra thermostat needed. Less components and failure modes.
• Alarm & event logs	• Make identification of errors fast and easy servicing.
• Fan speed control 40 - 100%.	• Reduced service costs.
• Start / stop delays	• Reduces noise.
• Advanced battery protection function	• Less components, less costs, less wiring, less installation costs.
• Meets EMI standards	• Safety. The battery will never be drained. Safe start of the truck every time.
	• The electronic unit meets automotive standards and in most cases no additional EMI filters required.

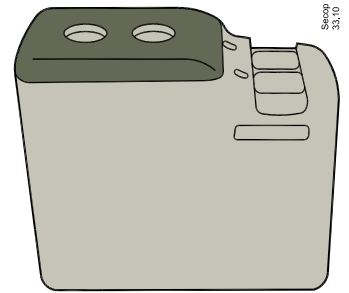
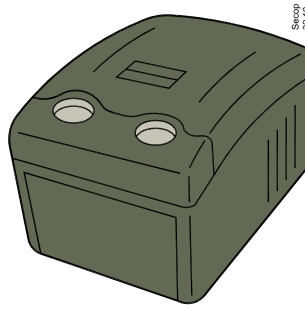
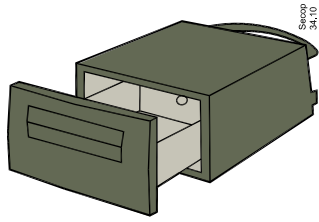

Cooling in medi boxes

BD1.4F-VSD • BD1.4F-FSD • BD35F • BD35K • BD50F • BD80F • BD80CN • BD100CN



Manufacturers and users of transport equipment for medicines, vaccines, blood plasma and organs know that it is of vital importance that these products are stored at the right temperature during transport. Vaccines and stored blood for example may only be given, if the temperature gradient during transport is completely provable. Similar high requirements apply to protein medicines, dialysis preparations and organs.

The Secop compressors produced for Danfoss BD35F and BD50F compressors are tailored for temperature controlled transportation. They ensure that the temperature can be kept at a constant temperature within the range of -18°C to +8°C and are therefore unsurpassed to be used in medi boxes for e.g. transport of medicines from main pharmacies to drugstores and organs from donor to recipient as well as storage of medicines and vaccines in ambulances.

The compressors from Secop compressors produced for Danfoss are universal for 12 and 24 V DC power supply and can be used in medi boxes up to 150 litres.

The compressors cover a capacity range from 20 to 180 W. Low and medium back pressure applications.

An electronic unit including protection against overload and destructive battery discharge controls the compressors.

The unit also features an internal voltage recording as well as calibration to the applied voltage (compressor monitoring).

The new BD1.4F-VSD has additional features such as fan speed control, built in electronic thermostat, communication interface which makes programming of the controller easy, without resistors and extra wiring.

Features	Benefits
<ul style="list-style-type: none"> Reliable compressor. More than 35 years in the market. 	<ul style="list-style-type: none"> High level of security. No damage to vaccines etc. due to too high temperatures.
<ul style="list-style-type: none"> High efficiency. Low current consumption 	<ul style="list-style-type: none"> Energy saving. Less batteries needed to cool over night.
<ul style="list-style-type: none"> Variable speed / capacity Direct 12 / 24 V DC power supply 	<ul style="list-style-type: none"> Energy savings. Adapt speed to cooling requirement. Same compressor can be used globally. One product covers the world.
<ul style="list-style-type: none"> Modbus communication connection 	<ul style="list-style-type: none"> Customers can make their own control box including control of the BD compressor. Possible to log temperatures via communication interface.
<ul style="list-style-type: none"> Electronic thermostat 	<ul style="list-style-type: none"> Very accurate temperature control. Cost savings. No extra thermostat needed. Less components and failure modes.
<ul style="list-style-type: none"> Alarm & event logs Fan speed control 40 - 100%. Start / stop delays 	<ul style="list-style-type: none"> Make identification of errors fast and easy servicing. Reduced service costs.
<ul style="list-style-type: none"> Advanced battery protection function 	<ul style="list-style-type: none"> Less components, less costs, less wiring, less installation costs.
<ul style="list-style-type: none"> Very low weight of compressor 	<ul style="list-style-type: none"> Safety. The battery will never be drained. Safe start of the van every time. Easy to carry a smaller medical box to small villages, even with a small battery mounted in the box.

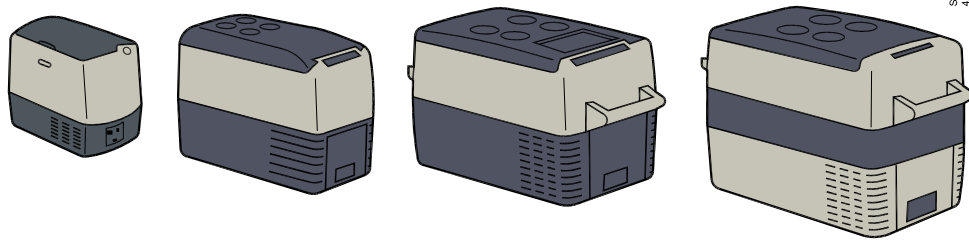

Secop
42.10



Solar assisted cooling



With BD solar compressors Secop compressors produced for Danfoss offers a refrigeration solution for places with poor or no power supply. Due to the exceptionally low starting current, batteries are not necessary if an ice bank is used for energy storage. BD solar compressors offers numerous functions for manufacturers within the rapidly growing area of mobile and stationary refrigeration. For example storage and transportation of drugs, storage of food under difficult conditions without power supply, ice cream stands in holiday resorts, remote bottle coolers, refrigerators in boats, just to name a few.

At times when there is no sun the ice packs keep the cabinet at the set temperatures. Its wide voltage range (10-45 V DC) makes the BD very suitable for photovoltaic powering.

An example on the latter was displayed at an UN Johannesburg Summit. On this occasion we supplied the compressor for a solar cabinet, complying with the tough demands of UNESCO (storage for 5 days without power supply). The concept is well accepted by WHO and UNICEF today.

Features	Benefits
<ul style="list-style-type: none"> • Reliable compressor. • More than 35 years in the market. • High efficiency. • Low current consumption • Variable speed / capacity • Direct 12 / 24 V DC power supply 	<ul style="list-style-type: none"> • High level of security. • No damage to vaccines etc. due to too high temperatures. • Energy saving. Less batteries needed to cool over night.
<ul style="list-style-type: none"> • Modbus communication connection • Electronic thermostat 	<ul style="list-style-type: none"> • Energy savings. Adapt speed to cooling requirement. • Same compressor can be used globally. One product covers the world. • Customers can make their own control box including control of the BD compressor. Possible to log temperatures via communication interface. • Very accurate temperature control. Cost savings. • No extra thermostat needed. Less components and failure modes. • Make identification of errors fast and easy servicing. • Reduced service costs.
<ul style="list-style-type: none"> • Alarm & event logs • Fan speed control 40 - 100%. Start / stop delays • Advanced battery protection function • Very low weight of compressor 	<ul style="list-style-type: none"> • Less components, less costs, less wiring, less installation costs. • Safety. The battery will never be drained. Safe start of a vehicle every time. • Easy to carry a smaller medical box to small villages, even with a small battery mounted in the box.

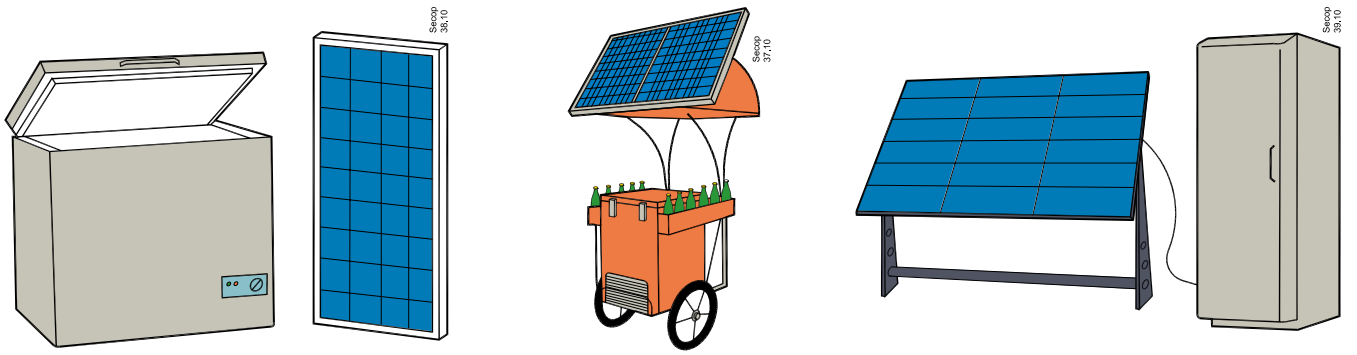

Cooling in portable cooling boxes

BD1.4F-VSD • BD1.4F-FSD • BD35F • BD35K • BD50F • BD80F



Today, more and more people want to spend their holiday in off-road exotic areas where there is no electricity power, but they still want to be able to cool their food and beverages. This has developed a market for portable cooling boxes.

The BD35F compressor is the ideal choice for this application. It is battery-powered, compact, light and easy to carry around. Also for a picnic or a holiday excursion with the family it is an independent compressor in the car to refrigerate the cooling box. And for a salesperson it is pleasant always to have chilled food and beverages at the hand.

The BD35F is universal for 12 and 24 V DC power supply. The compressor covers a capacity range from 20 to 130 W. Low and medium back pressure applications. Cooling boxes from 18-150 liters. The electronic unit is mounted on the compressor – this means no additional mounting costs.

The compressor operates with electronic as well as standard mechanical thermostats. It can be powered directly from an AC/DC unit. A switch in the power supply cables can be mounted to eliminate standby power consumption.

The BD compressors have internal voltage recording and calibration to the applied voltage as well as adjustable battery protection settings. The capacity is variable through motor speed regulation. An electronic unit including protection against overload and destructive battery discharge controls the compressors. The unit also features an internal voltage recording as well as calibration to the applied voltage (compressor monitoring). The new BD1.4F-VSD has additional features such as fan speed control, built in electronic thermostat, communication interface which makes programming of the controller easy, with out resistors and extra wiring.

Features	Benefits
• Low weight	• Only 2.3 kg for the smallest BD compressor makes it easy to carry.
• Small and compact	• 60 % less volume on BD1.4F-VSD/-FSD compared to BD35F.
• Silent operation	• Increase net volume of the box.
• High efficiency.	• The owner can sleep close to the box without being disturbed by a noisy compressor.
• Low current consumption	• Energy saving. Less battery capacity needed to keep the goods cooled.
• Variable speed / capacity	• Energy savings. Adapt speed to cooling requirement.
• Direct 12 / 24 V DC power supply	• Same compressor can be used globally. One product covers the world.
• AC/DC module available as option	• If grid power is available the box can be powered by mains power (100 - 240 V AC, 50/60 Hz).
• Electronic thermostat	• Cost savings. No extra thermostat needed. Less components and failure modes.
• Alarm & event logs	• Make identification of errors fast and easy servicing.
• Fan speed control 40 - 100%.	• Reduced service costs.
• Start / stop delays	• Reducing noise. Less components, less costs, less wiring,
• Advanced battery protection function	• less installation costs.
	• Safety. The battery will never be drained. Safe start of the car every time.

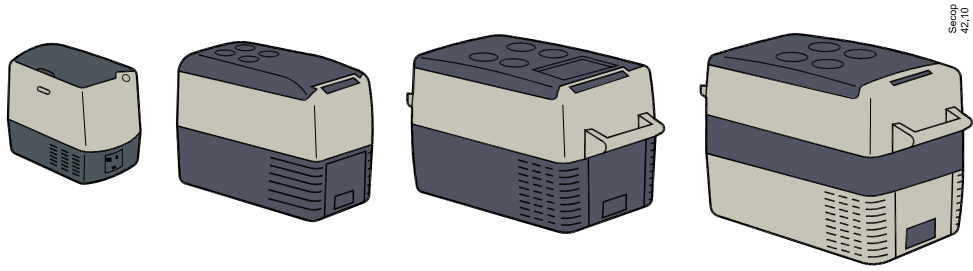

Secop
42,10



Control your cold chain

BD Van boxes

BD50F • BD80F • BD150F • BD250GH.2 • BD350GH • BD220CL



The most economical and efficient solution for small-scale transport is to use a mobile refrigeration unit that fits easily into cars and vans, and is powered by the car's own battery.

The advantages of such a solution are clear: It is no longer necessary to alter the vehicle. Cabinets can also be moved from vehicle to vehicle and even run on 220 V AC with the help of an inverter when the engine is turned off. In addition the systems are more energy efficient and can be custom built to a wide range of sizes – depending on storage requirements.

Finally, an expensive, impractical, specially adapted refrigerated van is no longer the only option on the market. In recent years, mobile cooling solutions have become increasingly competitive – and the latest solutions are far more economical, practical and efficient. In order to meet HACCP guidelines this is the most flexible and cost effective solution.

- Van can be bought as standard and no extra work at car "Body-builder"
- Refrigeration when the engine is stopped
- Possible to use both battery and AC utility by means of a converter
- The box is mobile and can be handled separately. Can be used as extra refrigerator and can be loaded directly in the cooling or freezer room
- Lower energy consumption (lower CO2 emission per kilometer)
- When not used to carry refrigerated food the car can be used for other purposes
- Reselling of the van much easier
- No hygiene issues at the car itself
- "Streamlined" car (lower wind resistance - lower energy consumption - lower CO2 emission)
- Operation and service much easier

Features	Benefits
• Runs directly on the car batteries	• Keeps the goods active cooled also when the van is stopped for loading and unloading.
• High efficiency.	• Energy savings.
• Low current consumption	• Makes it possible to cool also when the van's motor is stopped.
• Variable speed / capacity	• Energy savings. Adapt speed to cooling requirement.
• Direct 12 / 24 V DC power supply	• Same compressor can be used globally. One product covers the world.
• Modbus communication connection	• Customers can make their own control box including control of the BD compressor.
• Electronic thermostat	• Cost savings.
• Alarm & event logs	• No extra thermostat needed. Less components and failure modes.
• Fan speed control 40 - 100%.	• Make identification of errors fast and easy servicing.
• Start / stop delays	• Reduced service costs.
• Advanced battery protection function	• Less components, less costs, less wiring, less installation costs.
	• Safety. The battery will never be drained. Safe start of the van every time.

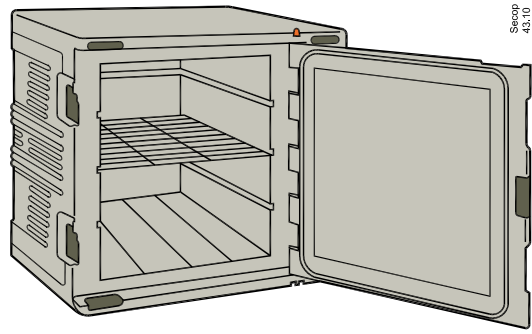

Telecom cooling increase battery lifetime

BD250GH.2 • BD350GH



When power fails, battery cooling systems must draw on the batteries' power. As the compressor is the main power consumer, much can be gained with a solution that is extremely efficient without being overly power hungry.

By using a battery powered direct current (DC) compressor, it is possible to build a cooling system that can run on batteries, solar cells and wind turbines without needing to convert to alternating current (AC).

The BD250GH.2 and BD350GH compressors are unique as they are constructed with integrated fan control and electronic thermostat. In this way, it is possible to simplify the design of the overall system and still ensure maximum performance.

With battery drain being a big issue, it is important to use an energy efficient compressor with the highest COP possible.

Compared to other solutions that rely on AC and 230 V AC conversion, the BD250GH.2 and BD350GH compressors save up to 250 W per hour.

In areas that rely on battery power for up to 16 hours a day, you can be certain that Secop compressors produced for Danfoss will ensure that batteries will last as long as possible.

The optimal temperature for batteries is 25°C. Anything above this will shorten their life expectancy and provide their owners with an inconvenient replacement cost.

Features	Benefits
<ul style="list-style-type: none"> • Higher COP with DC compressors • Direct power supply to the compressor (32 - 62 V DC) • 100% cooling, also at grid power failure • Up to 90% less failure modes on BD compressors compared to ac solutions. • Modbus communication connection 	<ul style="list-style-type: none"> • Better efficiency. • Fast installation and less failure modes. • Maintaining lifetime of batteries save up to 20.000 USD over 8 years. • Reduced service costs and much better "Up time" of the BTS station.
<ul style="list-style-type: none"> • Electronic thermostat • Alarm & event logs • Fan speed control 40 - 100%. • Start/stop delays 	<ul style="list-style-type: none"> • Customers can make their own control box including control of the BD compressor. Remote monitoring possible. • Cost savings. No extra thermostat needed. • Less components and failure modes. • Make identification of errors fast and easy servicing. • Reduced service costs. • Less components, less costs, less wiring, less installation costs.

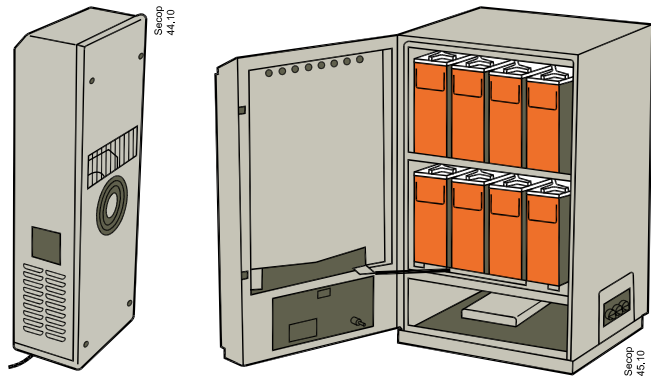

Mobile refrigeration in cars

BD1.4F-AUTO • BD1.4F-VSD • BD35F



Due to the increasing amount of time that people spend in their cars they want mobile refrigeration. With its compact design, low noise level and sturdiness against vibrations the BD compressor is the perfect solution for cool boxes in cars offering the driver and passengers the comfort not to stop every time they want food or drink. And when not on the road, the stowage box keeps cold for up to five hours after the car engine has been stopped. There are number of areas to place a cool box in a car. The centre console area is possibly the most obvious location, but the cool box can also be located under the passenger seat or even within the front passenger seat – where access is via a lift-up seat cushion.

Lose excess weight and use the extra space for what really matters. The new BD1.4F-AUTO and the BD1.4F-VSD from Secop compressors produced

for Danfoss are 60% smaller than previous models and weigh in at only 2.3 kilos. Perfect for 10-15 litre in-car cabinets that need to fit into tight spaces without compromising storage space.

Specially designed for maximum efficiency and reliability this tiny powerhouse of a compressor makes it easier than ever to provide leading class mobile fridges to the discerning automobile manufacturers.

The optimized, low-noise motor ensures outstanding performance when you want to provide that extra degree of luxury on the move.

Cool beverages on demand make driving so much more of an experience. Fridges using the BD1.4F-AUTO or the BD1.4F-VSD take up less space and allow small fridges to fit easily, with maximum storage space for snacks and beverages. Low energy consumption is good for car batteries – and the environment.

Features	Benefits
• Low weight	• Only 2.3 kg for the smallest BD compressor.
• Small and compact	• Overall weight reduction in the car.
• Silent operation	• 60 % less volume on BD1.4F-AUTO/-VSD compared to BD35F.
• High efficiency.	• Increase net volume of the box.
• Low current consumption	• The owner can sleep close to the box without being disturbed by a noisy compressor.
• Variable speed / capacity	• Energy saving. Less battery capacity needed to kept the goods cooled.
• Direct power supply	• Energy savings. Adapt speed to cooling requirement.
• Transport stable	• Same compressor can be used globally. One product covers the world.
• Electronic thermostat	• Long lifetime. Minimum of spareparts.
• Alarm & event logs	• Cost savings. No extra thermostat needed.
• Fan speed control 40 - 100%.	• Less components and failure modes.
• Start / stop delays	• Make identification of errors fast and easy servicing.
• Advanced battery protection function	• Reduced service costs.
• Meets EMI standards	• Reducing noise.
	• Less components, less costs, less wiring, less installation costs.
	• Safety. The battery will never be drained. Safe start of the car every time.
	• The electronic unit meets automotive standards.

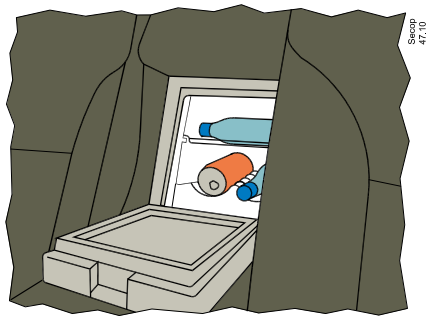
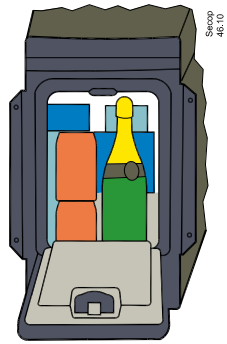

Mobile refrigeration in buses

BD1.4F-VSD • BD35-B • BD35F • BD50F



Many coaches offers passengers to buy cold beverages during a long tour.

The compressors from Secop compressors produced for Danfoss are universal for 12 and 24 V DC power supply and can be used in all kind of busses. They are unsurpassed to tolerate changeable climatic conditions and vibrations under harsh road conditions. The BD1.4F-VSD, BD35F, BD35F-B and BD50F compressors cover a capacity range from 20 to 180 W.

Low and medium back pressure applications.

A special version of the electronic unit will adapt the capacity of the compressor automatically (AEO) to the actual load on the refrigeration system. The algorithm will adjust the speed of the compressor so that a running time of approximately 30 minutes is achieved.

This is the most energy efficient way to operate the compressor.

The BD1.4F-VSD offers an ECO functions which adapt speed of the compressor to an optimum. It has additional features such as fan speed control, built in electronic thermostat, communication interface which makes programming of the controller easy, without resistors and extra wiring.

Refrigerator sizes up to 30-50 liters with freezer compartment. The compressors are controlled by an electronic unit including protection against overload and destructive battery discharge. The unit also features an internal voltage recording as well as calibration to the applied voltage (compressor monitoring).

Features	Benefits
• Low weight	• Only 2.3 kg for the smallest BD compressor makes it easy to carry.
• Small and compact	• 60 % less volume on BD1.4F-VSD compared to BD35F.
• Silent operation	• Increase net volume of the box.
• High efficiency.	• The owner can sleep close to the box without being disturbed by a noisy compressor.
• Low current consumption	• Energy saving. Less battery capacity needed to kept the goods cooled.
• Variable speed / capacity	• Energy savings. Adapt speed to cooling requirement.
• Direct 12 / 24 V DC powersupply	• Same compressor can be used globally. One product covers the world.
• Special designed BD for buses.	• BD35F-B reduces any noise from the compressor compressor to an absolute minimum even on very bumpy roads.
• Electronic thermostat	• Cost savings. No extra thermostat needed. Less components and failure modes.
• Alarm & event logs	• Make identification of errors fast and easy servicing.
• Fan speed control 40 - 100%. Start / stop delays	• Reduced service costs.
• Advanced battery protection function	• Reducing noise. Less components, less costs, less wiring, less installation costs.
• Meets EMI standards	• Safety. The battery will never be drained. Safe start of the bus every time.
	• The electronic unit meets automotive standards and in most cases no additional EMI filters required.

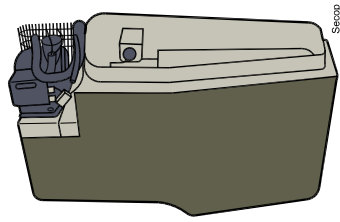

Secop
46.10

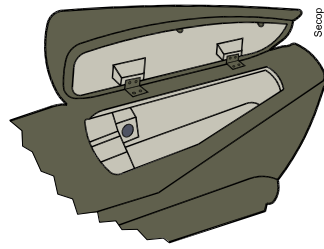

Secop
41.10



Part 3

DC Compressors Basics

1.	Secop compressors produced for Danfoss variable Speed for Direct Current compressors	39
1.1	Refrigerants.....	40
1.2	Handling of refrigerants.....	40
1.3	Charging with refrigerant.....	40
1.4	Replacement of refrigerant.....	40
1.5	HFC refrigerants (R134a)	40
1.6	Flammable refrigerants R290 and R600a	41
1.7	Connectors.....	41
1.8	Advantages of direct current compressors	42
1.9	Denomination - Key to DC-Compressor type designation	42
1.10	Date code & country of origin	43
1.11	Country of origin on typelabel.....	43
1.12	Typelabels overview.....	44
1.13	Labels on electronic units.....	44
1.14	Label design (exception BD150F).....	45
1.15	VDE/UL approved compressor - electronic unit combinations.....	45
2.	Electronic Units - Technical Data.....	46
3.	Electronic Units - Housings	48
4.	Electronic Units - Features.....	50
4.1	Voltage ranges with compressors	50
4.2	Cable dimensions	51
4.3	Compressor speed control	51
4.4	Thermostat connection.....	51
4.5	Adaptive Energy Optimization (AEO) function	51
4.6	AEO function for BD35F/K and BD50F	52
4.7	AEO function for BD80F, BD250GH.2 and BD100CN.....	52
4.8	ECO function.....	53
4.9	Fan connections	53
4.10	Fan output power.....	54
4.11	Lamp connection	54
4.12	Fault detection and diagnosis.....	54
4.13	Overload protections	55
4.14	Battery protection	56
4.14.1	Electronic units 101N0210 /220/230/290/320/330/500/600/630.....	57
4.14.2	Electronic unit 101N1010.....	57
4.14.3	Electronic units 101N2600 and 101N5200.....	58
4.14.4	Electronic units 101N2100 and 101N5100.....	58
4.15	Mounting the electronic unit.....	59
4.16	Mounting the remote kit	59
5.	Precondition for long operating Life.....	60
5.1	Motor overload.....	60
5.2	Thermal overload.....	60
6.	Design limits	61
6.1	Coil temperature	61
6.2	Condensing temperature.....	61
7.	Moisture and Impurities	62
7.1	Filter drier selection	62
8.	Condition at Delivery / Warnings	63
9.	Max. Refrigerant Charge	64
10.	Conversions.....	65
11.	Mounting the compressor.....	66
11.1	Connector positions.....	66
12.	Mounting Accessories.....	67
13.	Shipment Positions.....	68

1. Secop compressors produced for Danfoss variable speed for direct current compressors

Secop compressors produced for Danfoss variable speed compressors type BD (battery driven) BD1.4F-AUTO/-VSD/-FSD, BD35F, BD50F, BD80F, BD250GH.2, BD350GH and BD220CL are designed for connection to 12 - 24V DC and 48V DC power supply and for refrigerant types R134a (CH_2FCF_3) or R404A/R507 (CHF_2CF_3 , CH_3CF_3 , CH_2FCF_3 / CHF_2CF_3 , CH_3CF_3) and prepared for R1234yf ($\text{C}_3\text{H}_2\text{F}_4$).

The BD150F compressor is intended especially for the use in mobile applications, e.g. in vans and small trucks. It extends the application range of refrigerated transportation by increasing the capacity of Secop compressors produced for Danfoss's BD series. The extension was triggered by the EU directive on active refrigeration for food transportation, particularly frozen goods, fish etc.. The compressor makes it easier to comply with legal requirements and thus keep the refrigeration chain unbroken, even in traditionally weak links such as transportation for shops and supermarkets, supplies for hotels, restaurants etc.

The compressor concept includes an electronic unit which can operate on 230V AC, 50-60Hz. The electronic unit may also be powered directly from a 12/24V DC power supply using an appropriate inverter.

In addition to being especially quiet in operation, the BD150F compressor is a high-efficiency compressor.

The compressor is designed with semi-direct intake. Using the wrong connector as suction connector will lead to reduced capacity and efficiency.

The compressors are intended especially for use in mobile applications, e.g. cooling boxes, boats, caravans, trucks, vans and buses. Due to their low energy consumption and the option for a wide supply voltage range, the compressors are also very suitable for stationary applications powered by photovoltaic solar panels.

The compressors can be used in refrigerators and freezers using either capillary tube or TEV as the throttling device.

The compressors BD35K, BD80CN and BD100CN are especially designed for refrigeration systems using isobutane, refrigerant R600a (C_4H_{10}) and propane, refrigerant R290 (C_3H_8), respectively, as can be seen from the individual type label information. Isobutane and propane are also called hydrocarbons.

R600a and R290 are classified as flammable refrigerants of class A3 according to ANSI/ASHRAE 34. Accordingly, special safety regulations must be complied with. A special test schedule has been integrated in the European standards EN 60335-2-24 for domestic and EN 60335-2-89 for commercial appliances and in the corresponding international standards IEC 60335-2-24 and IEC 60335-2-89.

The compressors BD35K, BD80CN and BD100CN must only and exclusively be used in appliances certified for flammable refrigerants according to these or later regulations. This means that the compressors must only be used in appliances originally designed and certified for flammable refrigerant



BD Micro

BD P-Housing

BD T-Housing

Secop compressors produced for Danfoss are intended for use in mobile and stationary applications e.g. portable cooling boxes, boats, caravans, trucks, parking cooling in trucks, vans, buses and battery and shelter cooling in telecom stations. Due to the low power consumption and the option for a wide supply voltage range, the compressors are also suitable for stationary applications powered by photovoltaic solar panels, or fuel cells.

In bus applications a special version of BD35F-B has been developed. It is designed to minimize noise when the bus is driving.

In truck applications special versions, BD35F-HD and BD1.4F-VSD-HD, have been made to meet truck standards in regards to shock and vibration.

Hermetic Compressors for DC Voltage

1.1 Refrigerants

In accordance with the Montreal Protocol the use of CFC refrigerants (chloro-fluoro-carbons) has been discontinued. This also includes refrigerants such as R12 and R502. Within the foreseeable future HCFC refrigerants (partly halogenated chloro-fluoro-carbons) can no longer be used in Europe. In order to observe time limits for abandoning HCFC refrigerants, various refrigerants were developed to replace the old ones.

All new refrigeration units must operate with the remaining refrigerants, i.e. PFC (perfluorocarbons), HFC (hydrofluoro-carbons), hydrocarbons or inorganic refrigerants.

In the case of HFC refrigerant R134a a long-term replacement for the ozone-depleting R12 has been found. R134a has approximately the same thermodynamic properties as R12, which simplifies the conversion of installations. Secop compressors produced for Danfoss can offer a wide range of compressors designed for R134a refrigeration units.

In Germany, the flammable hydrocarbon refrigerants (such as R600a isobutane) have found widespread use in household appliances. Only time will tell whether the propagation of hydrocarbons will continue.

Until recently, the CFC refrigerant R502 was used in commercial refrigeration. There are some HFC-mixtures which will – in the long run – replace R502. Among these mixtures are R404A and R507. Instead of the HCFC refrigerant R22, R404A and R507 can also be used in commercial applications.

1.2 Handling of refrigerants

To ensure reasonable refrigeration system life, the refrigerant must have a maximum moisture content of 20 ppm (20 mg/kg). Do not fill the refrigerant from a large container into a filling bottle through several container sizes, as with every drawing-off the water content in the refrigerant is increased considerably.

1.3 Charging with refrigerant

Normally, charging with refrigerant is no problem with a suitable charge, provided that the charging amount of the refrigeration system equipment is known.

Always charge the refrigerant amount and type stated by the refrigerator manufacturer. In most cases this information is stated on the refrigerator type label. The different compressor brands contain different amounts of oil, so when converting to another brand it may be advisable to correct the amount of refrigerant. Charge of refrigerant can be made by weight or volume.

Flammable refrigerants like R600a and R290 must always be charged by weight. Charging by volume must be made with a refrigerant charging cylinder. The refrigerant R404A and all other refrigerants in the 400 series must always be charged as liquid.

If the charging amount is unknown, charging must be done gradually until the temperature distribution above the evaporator is correct. However, mostly it will be more appropriate to overcharge the system and then gradually draw off refrigerant until the correct charge has been obtained. The refrigerant charge must be made with the compressor running, the refrigerator without load and with the door closed.

The correct charge is characterized by the temperature being the same from the inlet to the outlet of the evaporator. At the compressor suction connector the temperature must be approx. ambient temperature. Thus transfer of moisture to the refrigerator insulation is avoided.

Systems with an expansion valve must be charged with refrigerant until there are no bubbles in the sight glass, which should be placed as close to the expansion valve as possible.

1.4 Replacement of refrigerant

The best solution for a repair is to select the same refrigerant as used in the same system. Secop compressors produced for Danfoss are supplied, or were supplied, in versions for the refrigerant R12, R22, R502, R134a, R404A/R507/R407C and for the flammable refrigerants R290 and R600a. The refrigerants R12 and R502, which are covered by the regulations in the Montreal Protocol, are only used in very few countries, and will eventually be phased out of production altogether.

For heat pump systems the refrigerant R407C is now used instead of R22 and R502. The more environmentally acceptable R134a has replaced R12, and the refrigerants R404A and R507 have replaced R22 and R502 in many applications.

1.5 HFC refrigerants (R134a)

The HFC refrigerant R134a and HFC mixtures require Polyester type oil. Contamination of components and systems with mineral oil and alkylbenzols must be avoided. Greasy substances and other long-chained, high molecular substances not dissolved must not be present. Manufacturing processes which require a lubricant can be done with Polyester oil approved for the compressors. Procedures for mounting, evacuation and charging must be carried out in such a way that contamination with chlorine refrigerants is avoided. HFC refrigeration systems must always have a drier with 3 Angstrom Molecular Sieves.

Hermetic Compressors for DC Voltage

1.6 Flammable refrigerants R290 and R600a

R600a and R290 are hydrocarbons. These refrigerants are flammable and are only allowed for use in appliances which fulfil the requirements laid down in the latest revision of EN/IEC 60335-2-24. (To cover potential risk originated from the use of flammable refrigerants). Consequently, R600a and R290 are only allowed to be used in household appliances designed for this refrigerant and fulfil the above-mentioned standard. R600a and R290 are heavier than air and the concentration will always be highest at the floor. R600a must only be stored and transported in approved containers and must be handled according to existing guidelines.

Do not use open fire near the refrigerants R600a and R290. The refrigeration systems must be opened with a tube cutter.

The flammability limits are approx. as follows,

Refrigerant	R600a	R290
Lower limit	1.5% by vol. (38g/m ³)	2.1% by vol. (39 g/m ³)
Upper limit	8.5% by vol. (203 g/m ³)	9.5% by vol. (177 g/m ³)
Ignition temperature	460°C	470°C

In order to carry out service and repair on R600a and R290 systems the service personnel must be properly trained to be able to handle flammable refrigerants. This includes knowledge on tools, transportation of the compressor and refrigerant, and the relevant regulations and safety precautions when carrying out service and repair.

Do not use open fire when working with refrigerants R600a and R290!

Conversions from refrigerants R12 or R134a to R600a is not permitted, as the refrigerators are not approved for operation with flammable refrigerants, and the electrical safety has not been tested according to existing standards either. The same applies to conversions from refrigerants R22, R502 or R134a to R290.

Secop compressors produced for Danfoss for the flammable refrigerants R600a and R290 are equipped with a yellow warning label as shown.



1.7 Connectors

BD compressors are supplied with sealed connectors, which consist of a thick walled copper plated steel tube with great corrosion resistance and good solder ability. The connectors are welded in the compressor housing and thus the welding cannot be destroyed by overheating during soldering operations. The sealing is an aluminium cap which gives a tight sealing. The seal is easily removed with an ordinary pair of pliers or with the tool shown in the figure.

Most BD compressors are supplied with millimetre tubes, but some variants supplied with inch tubes.

All connectors have a shoulder to provide optimal soldering conditions. Drifting of the connectors for more than 0.3 mm is not allowed.

For the refrigerants R600a and R290, process tubes can be closed with a LokRing® connection. Soldering is not allowed on systems with flammable refrigerants.

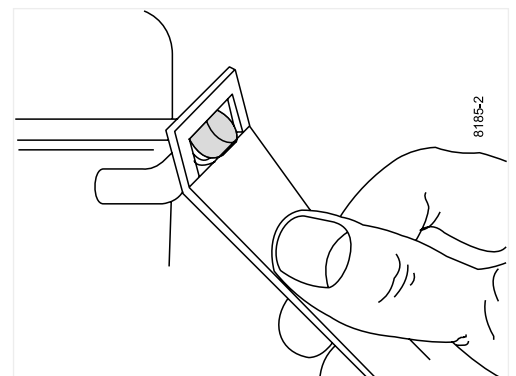

Hermetic Compressors for DC Voltage

1.8 Advantages of direct current compressors

Secop compressors produced for Danfoss can be used in applications using either capillary tube or TEV as the throttling device.

The BD compressor must be mounted in a dry and clean place. The compressors will withstand storage temperatures down to -35°C.

Condensing temperatures:

Max. 60°C at stable conditions and max. 70°C at peak load.

Ambient temperatures: Min. -10°C, max. 55°C

The BD compressor concept includes an electronic unit which features overload protection, battery protection, wrong polarity protection, evaporator and condenser fan control, LED diagnosis signal, light bulb connection, load dump protection, mechanical or electronic thermostat, ECO function, AEO (Adaptive Energy Optimizing) function and bus communication interface. These features are model dependant. The electronic module has internal voltage recording and calibration to the applied voltage. The electronic module may also be powered directly from certain types of electronic power supply units and thus no battery is required.

In addition to being especially quiet in operation – ranging from 33 dB(A) to 38 dB(A)- depending on model and speed of compressor, all BD compressors have high COP values.

The BD compressors are designed to be mounted in a horizontal position. However they are also designed to operate temporarily in conditions with heeling up to 30° such as can occur in boats, car and trucks driving in mountains. Under such heeling conditions the compressor can be noisy when internal compressor parts knock against the compressor shell.

Key to DC-Compressor Type Designation (BD-Series)

1 Compressor design	2 Compressor size		3 Application range	Refrigerant	4 Special features (optional, can be used in combination)	5 Generation
	Capacity at rating point	Displacement				
BD P/T-Housing	35		CN = LBP	R290	- HD = heavy duty (can handle extreme vibrations)	Blank > first generation
	50		CL = LBP	R404A/507	- AUTO = automotive	
BD Micro	150	1.4	F = LBP/MBP/HBP	R134a	- VSD = variable speed drive	
	250		GH = HBP	R134a	- FSD = fixed speed drive	
	350		K = LBP/(MBP)	R600a	- B = bus-optimized (optimized for rough vehicle motions)	

1.9 Denomination

- The first letter of the denomination indicates compressor series
- For BD-Micro compressors a number indicates the displacement in cm³, but for BD compressors based on P/T housing the number indicates the nominal capacity.
- The letter after the displacement indicates which refrigerant must be used as well as the field of application for the compressor.
LBP (Low Back Pressure) indicates the range of low evaporating temperatures, typically -10°C down to -35°C or even -45°C.
MBP (Medium Back Pressure) indicates the range of medium evaporating temperatures, typically -20°C up to 0°C.
HBP (High Back Pressure) indicates high evaporating temperatures, typically -5°C up to +15°C.
R134a > F: BD Compressors with denominations ending with F are primarily designed for low evaporating temperatures (LBP/MBP) but will also work with high evaporating temperatures (HBP).
R134a > GH: Compressors with denominations ending with GH are designed for high evaporating temperatures (HBP).
R290 > CN: Compressors with denominations ending with CN are designed for low evaporating temperatures (LBP) and medium evaporating temperatures (MBP).
R404A/R507 > CL: Compressors with denominations ending with CL are primarily designed for low evaporating temperatures (LBP).
R600a > K: All compressors for R600a have denominations ending with K after the number for displacement or capacity. They are designed for low operating temperatures (LBP).
- The next letter in the compressor denomination provides information on special features the BD compressor offers.
- The final letter (separated by a dot) mentions the generation of the compressor.

Hermetic Compressors for DC Voltage

1.10 Date code format & country of origin

Secop compressors produced for Danfoss have a manufacturing date code stamping on the housing.
The content of the coding (Fig.1) is in two lines according to the example below:
H4485C (6 characters)
051D11R (7 characters, 8 characters for BD Micro)

Composition of line 1

H4485: Compressor type information (102H4485 = H4485)
C: internal Secop compressors produced for Danfoss code

Composition of line 2

05: Production week
1: Production year
D: Production day
A = Monday, B = Tuesday,
C = Wednesday, D=Thursday, etc.
11: Production hour 00 to 23 or shift code -1, -2, -3
R: Secop compressors produced for Danfoss internal production location code
A to G, U Germany:
A until week 50/2005
D until week 35/2006
U until week 08/2010
K to N Slovenia:
K until week 39/2012
L until week 34/2011
M until week 02/2012
N until week 02/2012
A, D, L, M, R, U Slovakia:
A from week 01/2006
D from week 38/2006
L from week 45/2011
M from week 09/2012
R from week 01/2005
U from week 12/2010
S, R Mexico:
R up to week 27/2004
W to Z China



Fig.1 Needle print coding on compressor housing and country of origin on type label

1.11 Country of origin on typelabe

On BD Micro compressors (code number 109Z...), the production year is indicated by two digits, e.g. "11" for 2011 and a serial number behind the location code.

The country of origin (in capital letters) or the manufacturer will also be marked on the typelabel, examples:

- MADE IN SLOVAKIA
- for compressors made in Slovakia (Fig.2)
- Made by Secop compressors produced for Danfoss
- | optional label "Made in China"
- for compressors made in China (Fig.3)

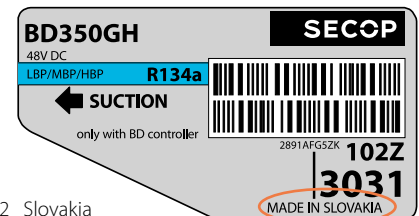

Fig.2 Slovakia

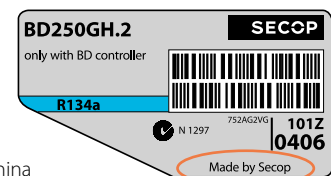

Fig.3 China

Hermetic Compressors for DC Voltage

1.12 Typelabels overview

BD Micro Series	Label Width = 47 mm	Example
Background colour	grey	
Coloured stripe for refrigerant	R134a: blue	
Barcode	on white background	
Approvals printed on label	yes	
Voltage printed on label	no	
Application printed on label	no	
BD Series based on P-Housing	Label Width = 67 mm	Example
Background colour	grey	
Coloured stripe for refrigerant	R134a: blue, R600a or R290: red	
Barcode	on white background	
Approvals printed on label	yes (except VDE &UL)	
Voltage printed on label	no	
Application printed on label	no	
BD Series based on T-Housing	Label Width = 85 mm	Example
Background colour	grey	
Coloured stripe for refrigerant	R134a: blue, R404A/R507: lilac	
Barcode	on white background	
Approvals printed on label	yes (except VDE &UL)	
Voltage printed on label	yes	
Application printed on label	yes	
BD150F based on T-Housing	Label Width = 85 mm	Example
Background colour	yellow	
Coloured stripe for refrigerant	R134a: blue	
Barcode	on white background	
Approvals printed on label	yes	
Voltage printed on label	yes	
Application printed on label	yes	

Note: The remark "only with BD controller" will be introduced on all BD compressors in the mid of 2013.

1.13 Labels on electronic units

Labels on electronic units	Examples
<p>Secop compressors produced for Danfoss labels on electronic units consist of a 2D Data Matrix code area and a number of lines with informations. The 2D Data Matrix Code is always built up with 62 characters containing information about type, code number, product version, product revision, unit ID, supplier, part number and text.</p> <p>Text information on the label:</p> <p>Line 1: ID: PLYYWWssssss (unique number)</p> <p>Line 2: Date: YYWW</p> <p>Line 3: Ver: VV</p> <p>Line 4: Text: text</p> <p>Meaning:</p> <p>PL Production location, 01 ... 99</p> <p>YY Year, 12 = 2012</p> <p>WW Week number, 01 ... 52</p> <p>ssssss Serial number, 000001 ... 999999</p> <p>VV Version, 00 ... 99</p>	

Hermetic Compressors for DC Voltage

1.14 Label design (exception BD150F)

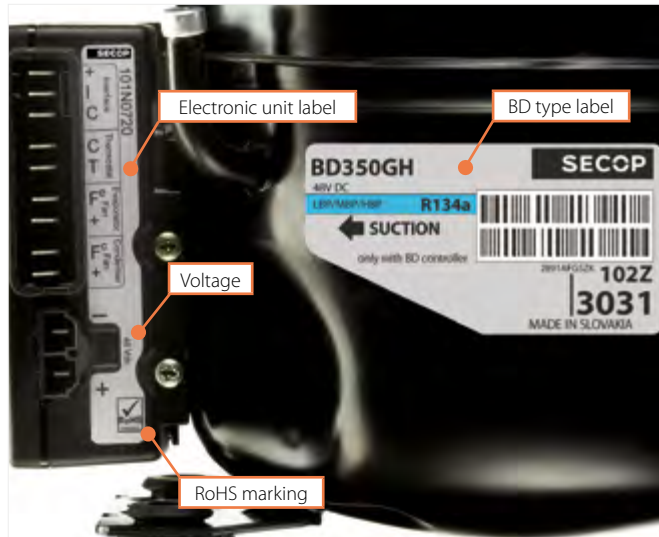

A lot of our BD compressors have VDE and UL approvals. Approved compressor - electronic unit combinations can be found in the table below.



UL approval mark

Nominal voltage has been removed from BD compressor type labels based on the P-housing and moved to the electronic unit. Application marking (LBP/MBP/HBP) has been removed on BD compressors based on the P- and BD-Micro housings. The European CE mark has been removed from most electronic units. On the AC/DC units it will remain. VDE marking will not appear on the BD type label due to the fact that the compressor can be applied with non VDE approved electronic units. The label on the electronic unit contains the nominal supply voltage. Located between + and - terminal. AC/DC units contain in addition the applied nominal AC voltage.

1.15 VDE/UL approved compressor - electronic unit combinations (BD P-Housing)

Compressorsw		Electronic Units					
		Standard	EMI	High start	High speed	AEO EMI	AEO high start
		101N0210	101N0220	101N0230	101N0290	101N0320	101N0330
BD35F mm	101Z0200	UL	UL				
BD35F inch	101Z0204	UL	UL				
BD35K (R600a)	101Z0211						
BD50F mm	101Z1220	UL	UL	UL			
BD50F inch	101Z0203	UL	UL	UL			
BD80F mm	101Z0280						
BD250GH.2	101Z0406						
BD80CN (R290)	101Z0403			UL			
BD100CN (R290)	101Z0401						

Compressors		Electronic Units					
		Solar	Solar	AC/DC converter	Automotive	Automotive	Telecom
		101N0400	101N0410	101N0500	101N0600	101N0630	101N0732
BD35F mm	101Z0200	UL		VDE/UL			
BD35F inch	101Z0204	UL		VDE/UL			
BD35K (R600a)	101Z0211						
BD50F mm	101Z1220			VDE/UL			
BD50F inch	101Z0203			VDE/UL			
BD250GH.2 (48V)	101Z0405						UL

VDE/UL = Combination possible, VDE or UL approval

□ = Combination not possible

□ = Combination possible, but no approval

2. Electronic units - Technical data

Technical data		Electronic units (code number)								
		BD, P-Housing								
		Standard 101N0210	EMI 101N0220	High Start 101N0230	High Speed 101N0290	AEO EMI 101N0320	AEO High Start 101N0330	Solar 101N0400	Solar 101N0410	AC/DC converter 101N0500
Approvals	Approvals and certificates *	UL	UL	UL	-	-	-	UL	-	UL, VDE
	Type approval (E-marking) 2004/104/EC	e4 03 1587	e4 03 1587	e4 03 1587	-	-	-	-	-	e4 03 1588
	EC declaration 2004/108/EC	-	-	-	-	-	-	-	-	yes
	Further EMC tests	-	-	-	-	-	-	-	-	-
Supply voltage	DC supply voltage range (V)	9.6 - 17, 21.3 - 31.5	9.6 - 17, 21.3 - 31.5	9.6 - 17, 21.3 - 31.5	9.6 - 17, 21.3 - 31.5	9.6 - 17, 21.3 - 31.5	9.6 - 17, 21.3 - 31.5	10 - 30	20 - 45	9.6 - 17, 21.3 - 31.5
	AC supply voltage range (V)	-	-	-	-	-	-	-	-	100 -240
	Frequency (Hz)	-	-	-	-	-	-	-	-	50-60
	Fuses required for e.g. 12/24V DC usage (A)	15 / 7.5	15 / 7.5	15 / 7.5	30 / 15	15 / 7.5	15 / 7.5	15	7.5	15 / 7.5
	Fuse required AC usage	-	-	-	-	-	-	-	-	4
Environments	Ambient temperature operation (°C)	55	55	55	55	55	55	55	55	55
	Ambient temp. during storage/transport (°C)	-40 to 85	-40 to 85	-40 to 85	-40 to 85	-40 to 85	-40 to 85	-40 to 85	-40 to 85	-40 to 85
Enclosure	IP Class	20	20	20	20	20	20	20	20	20
	Weight (kg)	0.27	0.34	0.28	0.32	0.31	0.31	0.26	0.26	0.43
Connectivity	Connectors (6.3 mm spades or purpose-built)	spades	spades	spades	spades	spades	spades	spades	spades	spades
	Fan (V/W _{max})	12 / 6	12 / 6	12 / 6	12 / 5	12 / 6	12 / 6	12 / 6	12 / 6	12 / 6
	NTC sensor	-	-	-	-	-	-	-	-	-
	Bus communication	-	-	-	-	-	-	-	-	-
	Light (V/W)	-	-	-	-	-	-	-	-	12 / 5
	LED (alarm)	yes	yes	yes	yes	yes	yes	yes	yes	yes
	TOOL4COOL®	-	-	-	-	-	-	-	-	-
	Setpoint selection (mechanical thermostat -M / (external resistor -R / TOOL4COOL® - T)	M / - / -	M / - / -	M / - / -	M / - / -	M / - / -	M / - / -	M / - / -	M / - / -	M / - / -

* please refer to table: VDE/UL approved compressor - electronic unit combinations

Hermetic Compressors for DC Voltage

Electronic units (code number)												
BD, P-Housing			BD, T-Housing					BD-Micro				
Automotive 101N0600	Automotive 101N0630	Telecom 101N0732	101N8xxx-Series 101N0820+0800	101N8xxx-Series 101N0820+0810	101N8xxx-Series 101N0830	101N07xx-Series 101N0715	Telecom 101N0720	Variable Speed (VSD) 101N2100	Variable Speed (VSD) AC/DC conv. 101N5100	Fixed Speed (FSD) 101N2600	Fixed Speed (FSD) AC/DC conv. 101N5200	Automotive (AUTO) 101N1010
-	-	UL	-	-	-	-	-	-	UL, VDE, CCC	-	UL, VDE, CCC	-
e4 03 1579	e4 03 1732	-	-	-	-	-	-	compliant	compliant	compliant	compliant	compliant
-	-	yes	-	-	-	-	yes	yes	yes	yes	yes	-
-	CISPR25/1	-	CISPR25/1	-	pending	CISPR25/3	-	CISPR25/1	CISPR25/1	CISPR25/1	CISPR25/1	VW 80101
9.6 - 17, 21.3 - 31.5	9.6 - 17, 21.3 - 31.5	32 - 60	9.6 - 17	19 - 31.5	9.6 - 17	19 - 31.5	32 - 60	9.6 - 17 19 - 34	9.6 - 17 19 - 34	9.6 - 17 19 - 34	9.6 - 17 19 - 34	8.5 - 17
-	-	-	-	-	-	-	-	-	100 - 240	-	100 - 240	-
-	-	-	-	-	-	-	-	-	50 - 60	-	50 - 60	-
15 / 7.5	15 / 7.5	15	30 + 2 x 60	15 + 2 x 30	60	30	15	15 / 7.5	15 / 7.5	15 / 7.5	15 / 7.5	12
-	-	-	-	-	-	-	-	-	4	-	4	-
55	55	55	55	55	55	55	55	55	55	55	55	55
-40 to 85	-40 to 85	-40 to 85	-40 to 85	-40 to 85	-40 to 85	-40 to 85	-40 to 85	-40 to 85	-40 to 85	-40 to 85	-40 to 85	-40 to 85
20	20	20	20	20	20	20	20	42	42	20	20	40
0.18	0.18	0.24	0.28 + 0.33	0.28 + 0.25	0.28	0.27	0.27	0.11	0.29	0.11	0.29	0.17
spades	special	spades	special	special	special	spades	spades	spades	spades	spades	spades	special
12 / 10	12 / 10	48 / 60+60	12-24 / 200+100	12-24 / 200+100	-	12+24 / 60+40	48 / 60+60	12 / 6	12 / 6	12 / 6	12 / 6	12 / 7.8
-	-	yes	yes	yes	yes	yes	yes	yes	yes	yes	yes	yes
-	-	1 wire	1 wire, LIN, Modbus	1 wire, LIN, Modbus	1 wire	1 wire	1 wire	1 wire	1 wire	1 wire	1 wire	1 wire
12 / 5	12 / 5	-	-	-	-	-	-	-	12 / 5	-	12 / 5	LED
-	-	-	-	-	-	-	-	yes	yes	yes	yes	yes
-	-	yes	yes	yes	yes	yes	yes	yes	yes	yes	yes	yes
M / - / -	M / - / -	M / - / T	M / - / T	M / - / T	M / - / T	M / - / T	M / - / T	M / R / T	M / R / T	M / R / T	M / R / T	M / R / T

3. Electronic units - Housings

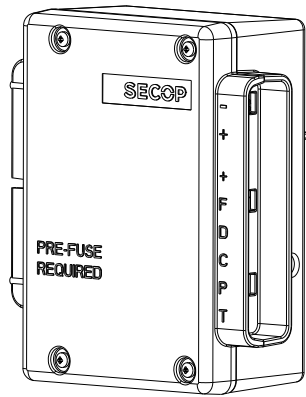

Standard
101N0210
High Start
101N0230

AEO
High Start
101N0330

Solar
101N0400
101N0410

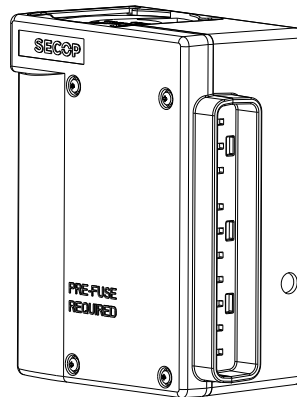

High Speed
101N0290

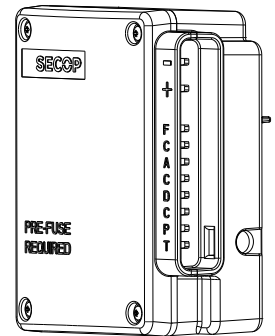

Automotive
101N0600

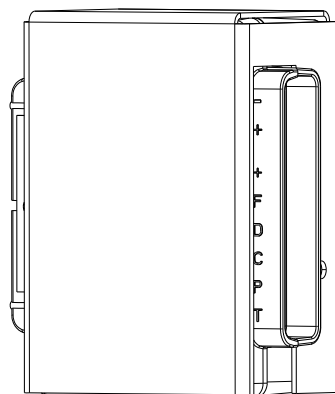

EMI
101N0220

AEO EMI
101N0320
with aluminium cover

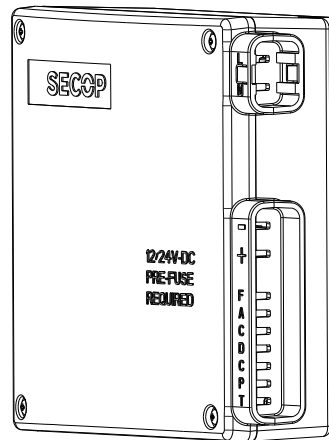

AC/DC converter
101N0500

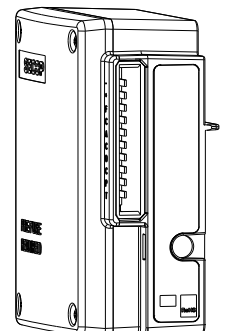

Automotive
101N0630

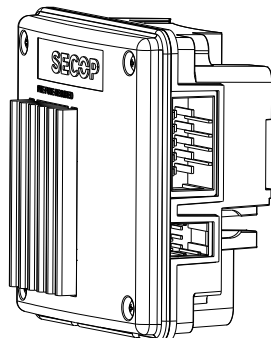

Automotive (AUTO)
101N1010

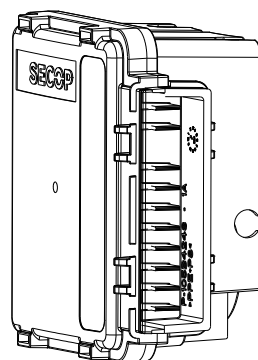

VSD
101N2100
FSD
101N2600

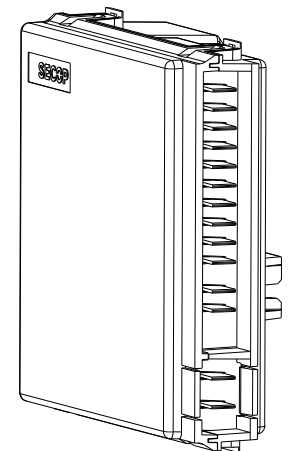

VSD w. AC/DC converter
101N5100
FSD w. AC/DC converter
101N5200

Hermetic Compressors for DC Voltage

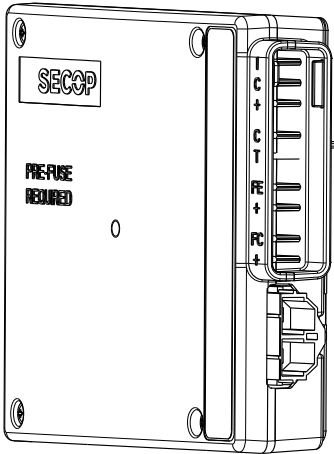

Telecom
101N0732

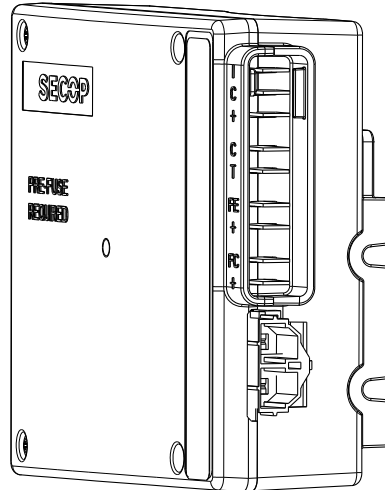

Telecom
101N0720

101N8xxx-Series
101N0800

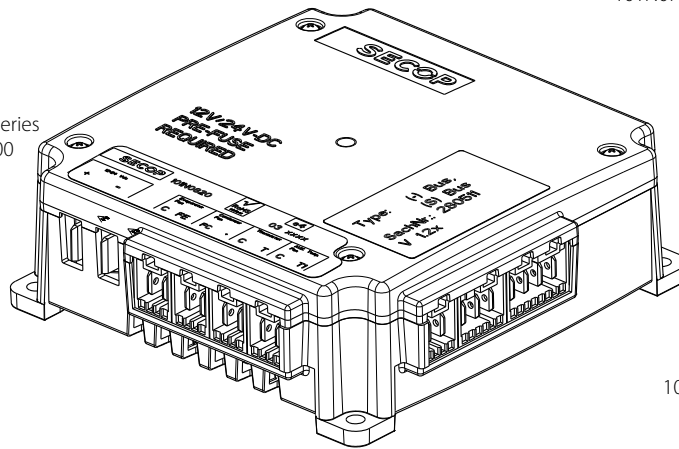

101N07xx-Series
101N0715

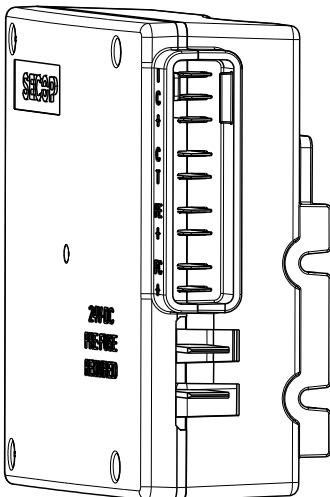

101N8xxx-Series
101N0810
101N0820
101N0830

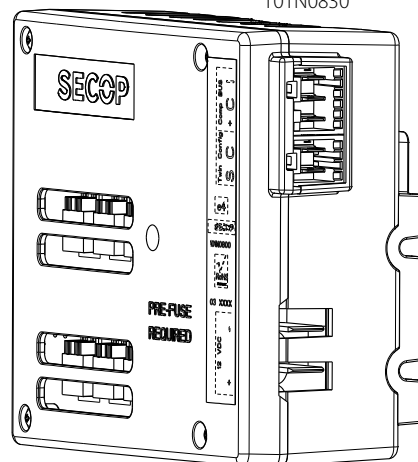

4. Electronic units - features

4.1 Voltage ranges with compressors

Secop compressors produced for Danfoss are fitted with brushless direct current motors (BLDCM) which are electronically commutated by an electronic unit.

The electronic unit is delivered separately and for most of the units, be mounted on the compressor. A few units must be mounted separately from the compressor. Please follow our Instructions. The electronic unit must always be connected directly to the battery poles or power supply unit terminals. For the protection of the installation an external fuse must be installed in the power supply cable close to the battery or power supply unit. If the chassis is used as a conductor, a proper connection between cable and chassis must be established. Wrong polarity applied to the electronic unit does not destroy the unit - however, the compressor will not work.

Some electronic units can run on either 12V DC or 24V DC. The electronic unit will be calibrated to the applied voltage. This means that if the battery voltage is less than 17V, the electric unit assumes that it is working in a 12V DC system. If the voltage is higher than 17V DC the electronic unit assumes that it is working in a 24V DC system. Voltages are measured on the power supply terminals of the electronic unit. If the compressor is planned to be stopped for long periods, a main switch can be installed.

For detailed function descriptions of the individual unit please, refer to our Instructions for that specific unit.

BD Compressors with various electronic units (P-Housing)	Voltage range	
BD35F /-HD /-B	9.6 – 31.5	
BD35F AC/DC	85 – 265 V AC, 50/60 Hz z	
BD35F Solar	option 1	9.6 - 30
	option 2	20 - 45
BD50F	9.6 – 31.5	
BD50F AC/DC	85 – 265 V AC, 50/60 Hz	
BD80F	9.6 – 31.5	
BD35K	9.6 – 31.5	
BD35K Solar	option 1	9.6 - 30
	option 2	20 - 45
BD80CN	9.6 – 31.5	
BD100CN	9.6 – 31.5	
BD250GH.2 12/24V	9.6 – 31.5	
BD250GH.2 48V	32 – 60	

BD Compressors with various electronic units (T-Housing)	Voltage range
BD350GH 24V	19 – 31.5
BD350GH 12/24V	9.6 – 31.5
BD350GH 48V	32 - 60
BD220CL	9.6 - 17
BD150F	160 – 254 V AC 50/60 Hz
BD Compressors with various electronic units (Micro Series)	Voltage range
BD1.4F-AUTO	8.5 - 17
BD1.4F-VSD /-HD	9.6 – 34
BD1.4F-VSD AC/DC	85 – 265 V AC, 50/60 Hz
BD1.4F-FSD	9.6 – 34
BD1.4F-FSD AC/DC	85 – 265 V AC, 50/60 Hz

Hermetic Compressors for DC Voltage

4.2 Cable dimensions

To ensure correct starting and operating conditions, the cable dimensions must be observed and sized correctly.
We recommend a maximum voltage drop of 0.3 V in the cable between power supply source and supply terminals on the electronic module.

Calculation of voltage drop = $0.0175 * (\text{cable length in meter} / \text{cable square in mm}^2) * 2 * \text{current in Ampere}$

Example:
Cable length = 5 meter
Cable square = 4 mm²
Current consumption = 6.5 A
Voltage drop = $0.0175 * (5/4) * 2 * 6.5 = 0.28 \text{ V}$.

4.3 Compressor speed control

All BD compressors have brushless DC motors and therefore speed/capacity control can be made in an easy way. The applied voltage to the motor inside is proportional with compressor speed.
Note - the voltage applied to the motor inside the compressor is not the same as supply voltage!
On BD35F/K, BD50F, BD80F/CN, BD100CN and BD250GH.2 the speed can be set via an external resistor in series with the thermostat circuit between terminal C & T.
For further details on the different electronic units please refer to the Instruction and Data Sheets for specific models.
On electronic units with communication interface the speed can be selected via PC software Tool4Cool®. Depending on the electronic unit the speed range varies. The BD1.4F-VSD compressor model offers speed control by means of Tool4Cool® or by means of an external resistor.
Please refer to Instructions and Operating Instructions for specific units.

For each electronic unit there is a built in protection function for over and under speed which stops the compressor when these limits are exceeded.

4.4 Thermostat connection

The electronic unit on the BD compressor can operate with normal mechanical type thermostats as used in refrigeration appliances, or with electronic thermostats. The thermostat is connected between the terminals C and T of the electronic unit. The compressor current does not flow through the thermostat contacts. When the thermostat is cut out there will still be power on to the electronic unit. A system with no stand-by power consumption can be established if the thermostat is replaced by a jumper between the terminals C and T, and the main switch is replaced by a thermostat. In this case the full current to the compressor flows through the thermostat, which must be rated accordingly.

Electronic units with communication interface have a built in electronic thermostat that controls the temperature via an NTC sensor connected to terminal C & T on the electronic unit. Recommended NTC sensor type Epcos M800/5K.
The thermostat can be adjusted via communication interface and PC software Tool4Cool®.
BD1.4F-VSD compressor model offers thermostat adjustment feature by means of PC software Tool4Cool® or by means of an external resistor.
For further details on thermostat function for the individual electronic units please refer to our Instructions.

4.5 Adaptive Energy Optimization (AEO) function

The AEO function is very suitable for tropical applications, systems with huge load variations and applications where energy is an important issue. Furthermore it can be an advantage to use it when it is difficult to determine at what speed the compressor should run.
Customers producing condensing units see this as the preferred solution. The function will prevent short cycling of the compressor and thereby protect the battery. The AEO is built into electronic modules with separate code numbers.
The AEO function can be overruled by means of a resistor to set a fixed speed.
See Instructions for details on resistor size. The AEO function only applies to electronic modules without bus communication interface.

4.6
AEO function for
BD35F/K and BD50F

Startup conditions. Every startup of the compressor takes place at low speed (soft start). The start up speed is equal to: the speed at thermostat cut out minus 400 rpm. After start up the speed of the compressor will be ramped up and adapted to the load. The ramp up speed is 12.5 rpm/min. The software algorithm adapts the capacity of the compressor to the actual load of the system. The unit regulates the capacity so that the compressor runtime is approximately 30 minutes. If the compressor does not reach cut out temperature within 60 min the speed is set to 3500 rpm.

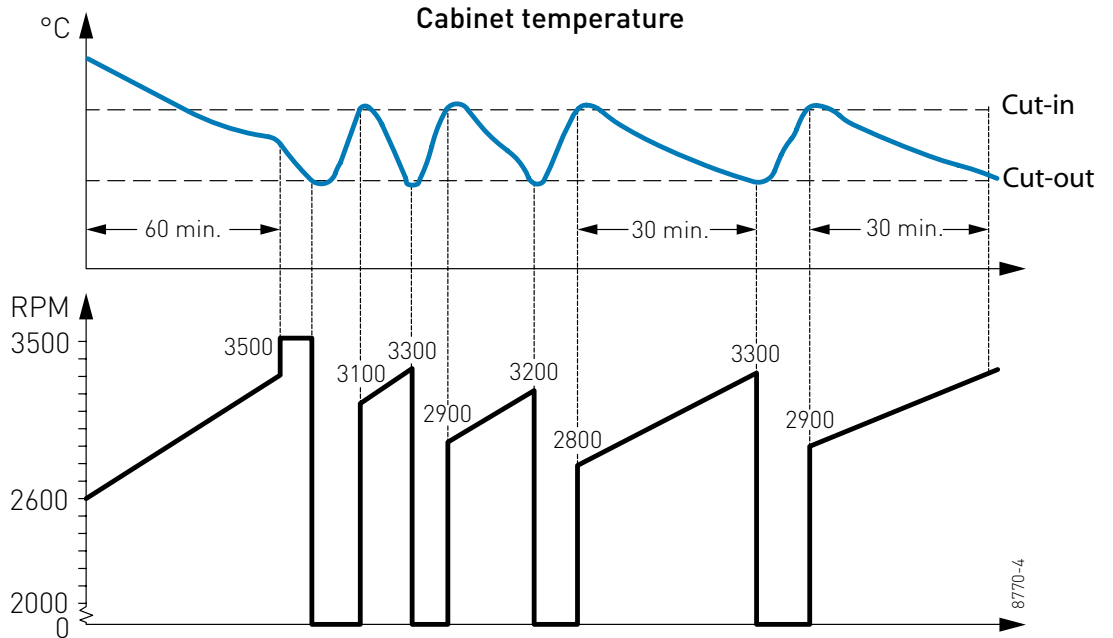

4.7
AEO function for BD80F,
BD250GH.2 and BD100CN

The AEO function for BD80F, BD250GH.2 and BD100CN compressors has slightly different timings. Every startup of the compressor takes place at low speed (soft start). The start up speed is equal to the speed at thermostat cut out minus 300 rpm. After start up the speed of the compressor will be ramped up and adapted to the load. The ramp up speed is 9.4 rpm/min. The software algorithm adapts the capacity of the compressor to the actual load of the system. The unit regulates the capacity so that the compressor runtime is approximately 24 minutes. If the compressor does not reach cut out temperature within 48 minutes the speed is set to 4400 rpm.

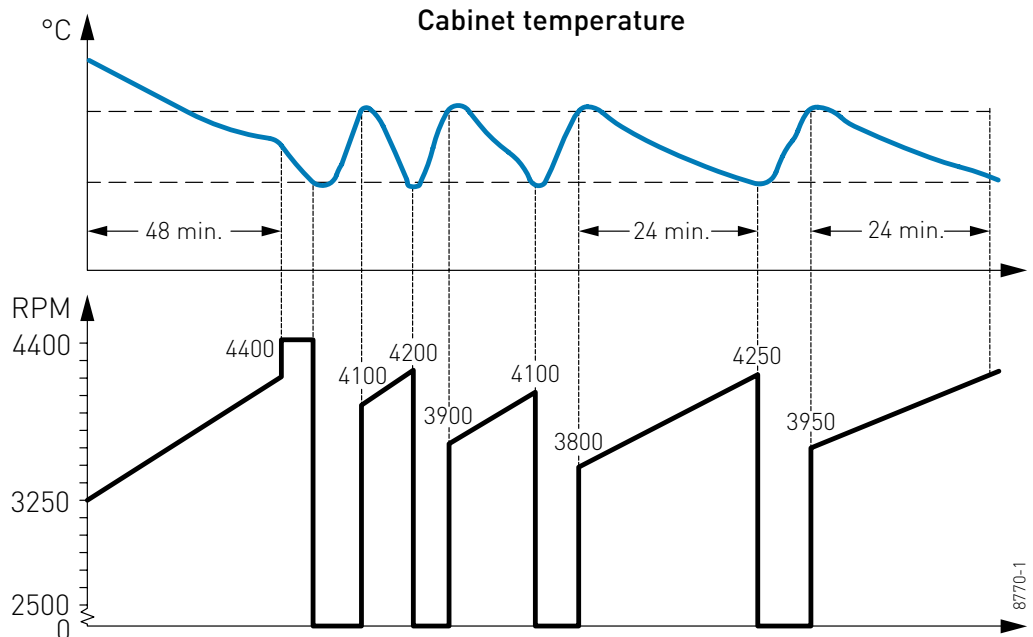

Hermetic Compressors for DC Voltage

4.8 ECO function

The ECO function mode reduces energy consumption and noise. It is a function that can be selected ON or OFF. An NTC must be connected to the electronic unit. ECO mode does not work if a mechanical thermostat is used. ECO is only available in electronic unit with bus communication interface. It can be activated via PC software Tool4Cool® or on some electronic units by means of an external resistor. The philosophy of ECO is to run at full compressor capacity when the temperature is above the thermostat cut-in temperature, and when the temperature is in the thermostat zone to run at ECO speed. This function is shown in the graph below.

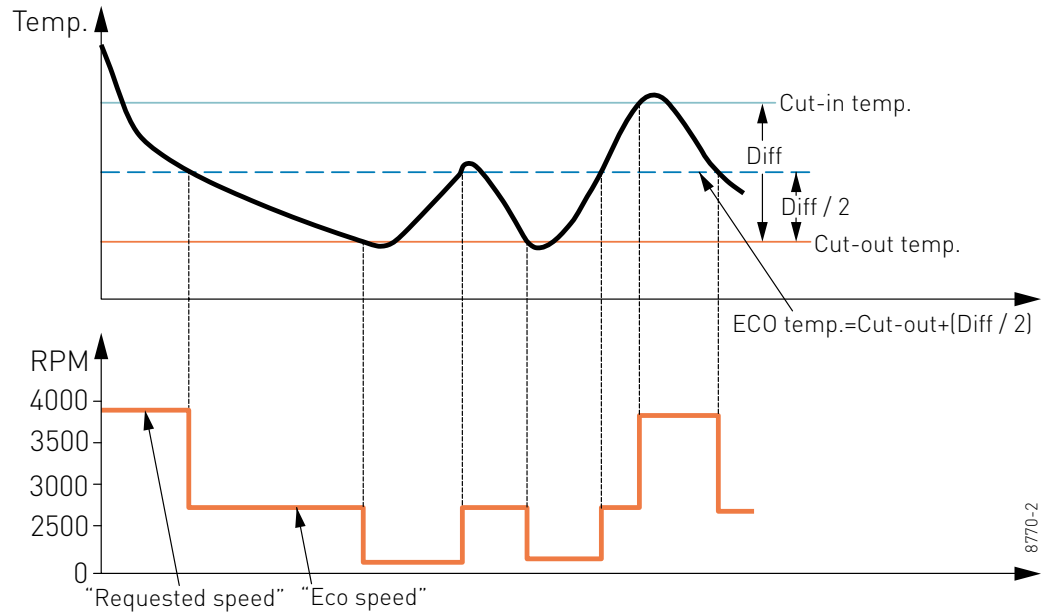

BD35F/K, BD50F, 80F/CN, 100CN and BD250GH.2

If a condenser fan is to be used, it must be connected to the electronic unit terminals + and F. On electronic unit 101N0600 a fan must be connected to C and F. Always use a 12V fan, including 24V systems, as the electronic unit will automatically reduce the applied voltage to 12V for the fan. Using the special solar electronic unit 101N0400, the fan runs with input voltage always. The max. load on the electronic unit is 0.5A avg or 1A peak. The fan is allowed to start with a higher current for the first 2 seconds. If the fan becomes overloaded, both fan and compressor will be cut out by the overload protection.

BD350GH, BD220CL, BD250GH.2 48 V and BD1.4F

Electronic units with communication interface via Tool4Cool® have fan speed control in the range from 40 to 100% controlled via a PWM signal.

Some of these controllers have the possibility to control both a condenser and evaporator fan via 2 fan outlets on the electronic unit.

Besides speed control it is possible to define a start and stop delay of the fans related to thermostat function. The table below shows the different settings that can be made via PC software Tool4Cool®. This varies from unit to unit.

Name	Default	Max. value	Min. value	Step	Unit
Cond. Fan voltage	24	31	12	1	Volt
Fan speed	100	100	40	10	%
Fan start delay	0	240	0	1	Seconds
Fan stop delay	0	240	0	1	Seconds
Fan forced ON	OFF	ON	OFF	1	-
Detect missing fan	OFF	ON	OFF	1	-

Hermetic Compressors for DC Voltage

4.10 Fan output power

Electronic Unit Code number	Fan output (Watt) and voltage	Electronic Unit Code number	Fan output (Watt) and voltage	Electronic Unit Code number	Fan output (Watt) and voltage
101N0210	6 / 12	101N0715	60/40 / 12 or 24 V	101N1010	6 / 12
101N0220	6 / 12	101N0720	60 / 48	101N2100	6 / 12
101N0230	6 / 12	101N0732	60 / 48	101N2600	6 / 12
101N0290	5 / 12	101N0800	100/200 / 12	101N5100	6 / 12
101N0300	6 / 12	101N0810	100/200 / 24	101N5200	6 / 12
101N0320	6 / 12				
101N0330	6 / 12				
101N0400	6 / 12				
101N0410	6 / 12				
101N0500	6 / 12				
101N0600	10 / 12				
101N0630	10 / 12				

4.11 Lamp connection

A 12V DC 5 Watt lamp can be connected between the terminals A and C on electronic unit 101N0500, 101N0600, 101N5100 and 101N5200. The output voltage between the terminals A and C is always regulated to 12V DC. A 12V DC lamp must be used for both 12V and 24V power supply systems. The lamp output can supply a continuous current of 0.5A avg

4.12 Fault detection and diagnosis

BD35F/K, BD50F, 80F/CN, 100CN and BD250GH.2 12/24 V

To diagnose why a compressor comes to an unintended stop, it is recommended to have a 10mA Light Emitting Diode (LED) installed between the terminals + and D. Provided that the electronic unit is properly connected to the power supply, and the thermostat is on, the number of flashes depends on what kind of operational error was recorded. Each flash will last ¼ second. After the actual number of flashes there will be a delay with no flashes, so that the sequence for each error recording is repeated every 4 seconds.

LED flashes when:

Battery voltage low: Battery must be charged. Hereafter start delay of 66 sec

Fan is overloaded: Restart made after 66 sec

Motor start error: Restart made after 66 sec

Compressor speed too low: Restart made after 66 sec

PCB temperature too high: Temperature must be below 90°C. Hereafter delay of 66 sec

BD350GH, BD220CL, BD250GH.2 48 V and BD1.4F

Electronic unit with communications interface via Tool4Cool® shows actual alarm message on the PC screen. Alarm messages (depending on electronic unit):

No error

Voltage failure

Fan failure

Motor failure

Min. speed failure

Max. speed failure

Thermal failure

NTC Sensor Failure

Some units also offer the possibility to connect an LED in order to get a flash pattern to identify the error. For details please refer to the Instructions for a specific unit.

4.13 Overload protections

In order to protect the electronic unit from destruction due to overheating a built in temperature sensor monitors the PCB temperature.

If the temperature exceeds 100°C. The compressor is stopped until the PCB temperature has dropped below 90°C. Hereafter the compressor will start again with a delay of approx. 1 minute (depends on the electronic unit).

The heat influencing the PCB comes from its surrounding temperature and the temperature generated in the PCB due to load, meaning that a higher load is possible when surrounding temperature is low and vice versa.

Electronic Unit Over-Temperature Protection

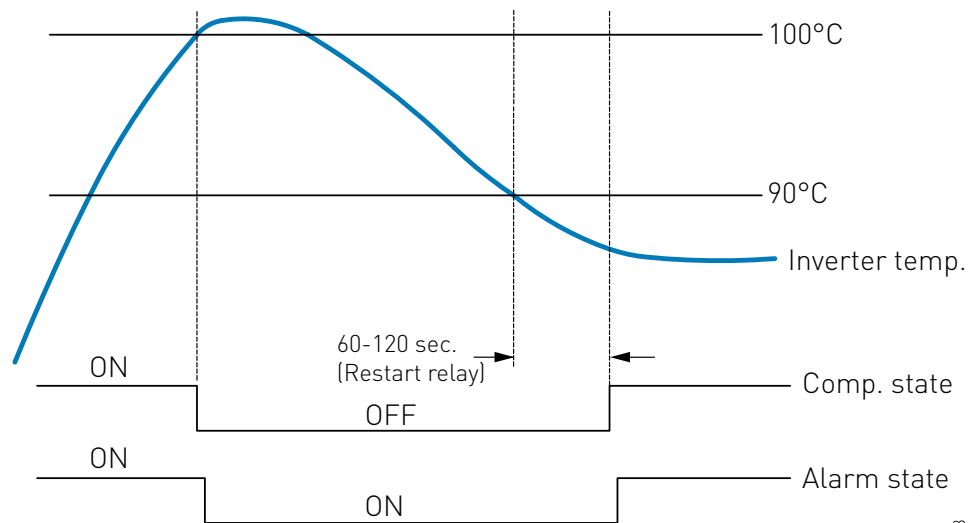

8770-3

4.14
Battery protection

BD35F/K, BD50F, 80F/CN, 100CN and BD250GH.2 12/24 V

To ensure sufficient battery power for proper compressor operation or to avoid permanent damage to the battery because of heavy discharge, the BD electronic unit also facilitates a battery protection function (except electronic unit 101N0400 & 101N0410). The compressor is stopped and restarted again according to the chosen voltage limits measured on the + and - terminals of the electronic unit. Other battery protection settings are optional if a connection, which includes a resistor, is established between terminals C and P. Please refer to our Instructions for wiring and resistor size for a specific electronic unit

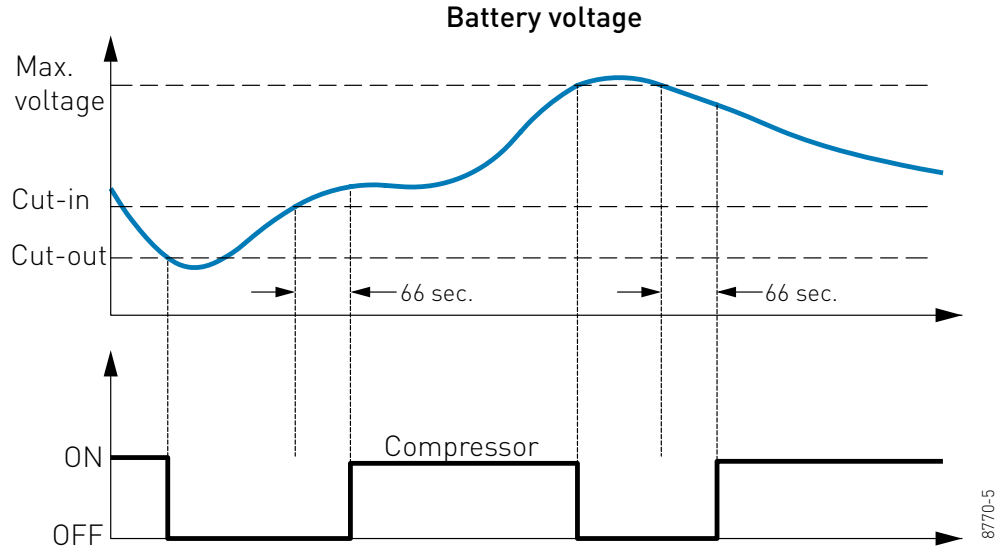

BD350GH, BD220CL, BD250GH.2 48 V and BD1.4F

To ensure sufficient battery power for proper compressor operation or to avoid permanent damage to the battery because of heavy discharge, the BD electronic unit also facilitates a battery protection function. Electronic units, with communication interface, can be accessed via PC software Tool4Cool®. This offers greater flexibility to set the cutout level of battery voltage and the difference when the compressor is allowed to start again after the battery has been charged.

If the max and min safety limits are exceeded the compressor will stop without any delay.

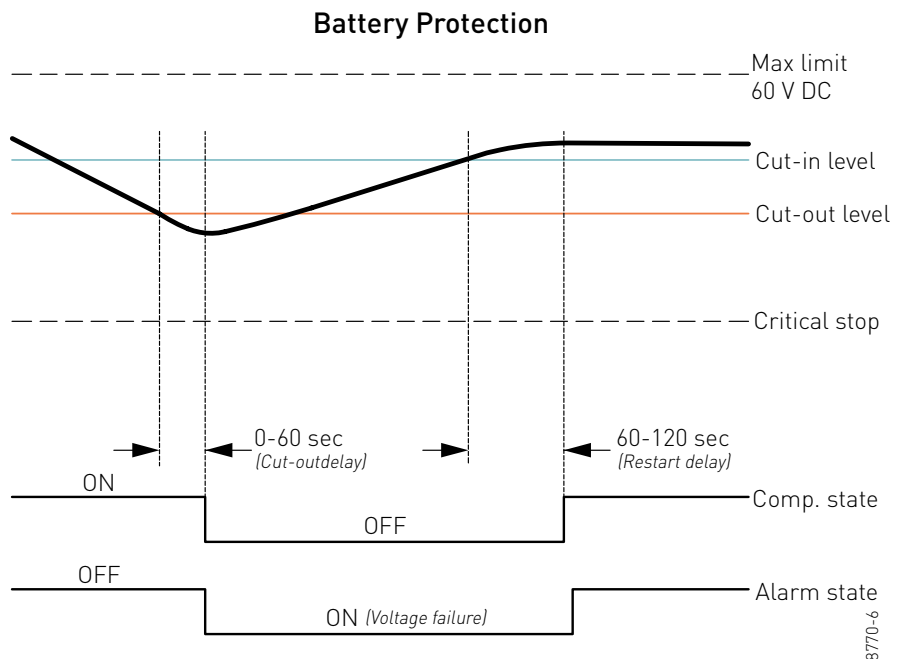

Hermetic Compressors for DC Voltage

4.14.1 Battery protection for electronic units 101N0210, 101N0220, 101N0230, 101N0290, 101N0320, 101N0330, 101N0500, 101N0600 and 101N0630

Standard battery protection settings

12V cut-out [V]	12V cut-in [V]	24V cut-out [V]	24V cut-in [V]
10.4	11.7	22.8	24.2

Optional battery protection settings

Resistor [kΩ]	12V cut-out	12V cut-in	12V max.	24V cut-out	24V cut-in	24V max.
terminals C - P	[V]	[V]	Voltage	[V]	[V]	Voltage [V]
0	9.6	10.9	17.0	21.3	22.7	31.5
1.6	9.7	11.0	17.0	21.5	22.9	31.5
2.4	9.9	11.1	17.0	21.8	23.2	31.5
3.6	10.0	11.3	17.0	22.0	23.4	31.5
4.7	10.1	11.4	17.0	22.3	23.7	31.5
6.2	10.2	11.5	17.0	22.5	23.9	31.5
8.2	10.4	11.7	17.0	22.8	24.2	31.5
11	10.5	11.8	17.0	23.0	24.5	31.5
14	10.6	11.9	17.0	23.3	24.7	31.5
18	10.8	12.0	17.0	23.6	25.0	31.5
24	10.9	12.2	17.0	23.8	25.2	31.5
33	11.0	12.3	17.0	24.1	25.5	31.5
47	11.1	12.4	17.0	24.3	25.7	31.5
82	11.3	12.5	17.0	24.6	26.0	31.5
220	9.6	10.9				31.5

4.14.2 Battery protection for electronic unit 101N1010

Standard battery protection settings

12V cut-out [V]	12V cut-in [V]
8.5	9.0

Optional battery protections settings

Resistor [kΩ]	12V cut-out	12V cut-in	12V max.
terminals S2 - C	[V]	[V]	Voltage [V]
0	9.60	10.90	17.0
0.17	9.73	11.03	17.0
0.34	9.86	11.16	17.0
0.54	10.00	11.30	17.0
0.75	10.12	11.42	17.0
0.97	10.25	11.55	17.0
1.23	10.38	11.68	17.0
1.50	10.52	11.82	17.0
1.81	10.65	11.95	17.0
2.15	10.78	12.08	17.0
2.53	10.91	12.21	17.0
2.96	11.04	12.34	17.0
3.44	11.17	12.47	17.0
3.99	11.30	12.60	17.0

4.14.3 Battery protection for electronic units 101N2600 and 101N5200

Standard battery protection settings

Voltage (0.1 steps)				Min. value	Default
12V	± 0.3V DC,	Cut-out	VDC	9.6	10.4
	all values	Cut-in diff.	VDC	0.5	1.3
24V	± 0.3V DC,	Cut-out	VDC	19	21.3
	all values	Cut-in diff.	VDC	0.5	1.3

Optional battery protection settings

Resistor [kΩ] terminals C - P	Duty Cycle [%]	Speed [RPM]	Cut-out level [V]	Cut-in level [V]	Cut-out level [V]	Cut-in level [V]
open	0	3,000	Maintain current value. Can be changed via Modbus.			
36	21	3,000	Reset battery to default value			
30	24	3,000	Reset battery to default value			
7.5	57	3,000	Maintain current value. Can be changed via Modbus.			
6.2	60	3,000	9.6	10.9	21.3	22.6
5.6	63	3,000	10.1	11.4	22.3	23.6
5.1	66	3,000	11.1	12.4	23.3	24.6
4.3	69	3,000	12.1	13.4	24.3	25.6

4.14.4 Battery protection for electronic units 101N2100 and 101N5100

Standard battery protection settings

Voltage (0.1 steps)				Min. value	Default
12V	± 0.3V DC,	Cut-out	VDC	9.6	10.4
	all values	Cut-in diff.	VDC	0.5	1.3
24V	± 0.3V DC,	Cut-out	VDC	19	21.3
	all values	Cut-in diff.	VDC	0.5	1.3

Optional battery protection settings and speed selection

Resistor [kΩ] terminals C - P	Duty Cycle [%]	Speed [RPM]	Cut-out level [V]	Cut-in level [V]	Cut-out level [V]	Cut-in level [V]	
open	0	Maintain	Maintain current value. Can be changed via Modbus				
220	3	-	Maintain current value. Can be changed via Modbus				ITC
130	6	-	Maintain current value. Can be changed via Modbus				ITC off
91	9	-	Maintain current value. Can be changed via Modbus				ECO
68	12	-	Maintain current value. Can be changed via Modbus				ECO off
51	15		9.6 - 34 V DC				Solar
43	18		Default				Solar off
36	21		Reset battery only				
30	24		Reset battery and speed to default value				
27	27	4000	Maintain current value. Can be changed via Modbus				
22	30	4000	9.6	10.9	21.3	22.6	
20	33	4000	10.1	11.4	22.3	23.6	
18	36	4000	11.1	12.4	23.3	24.6	
15	39	4000	12.1	13.4	24.3	25.6	
13	42	3500	Maintain current value. Can be changed via Modbus				
12	45	3500	9.6	10.9	21.3	22.6	
11	48	3500	10.1	11.4	22.3	23.6	
9.1	51	3500	11.1	12.4	23.3	24.6	
8.2	54	3500	12.1	13.4	24.3	25.6	
7.5	57	3000	Maintain current value. Can be changed via Modbus				
6.2	60	3000	9.6	10.9	21.3	22.6	
5.6	63	3000	10.1	11.4	22.3	23.6	
5.1	66	3000	11.1	12.4	23.3	24.6	
4.3	69	3000	12.1	13.4	24.3	25.6	
3.9	72	2500	Maintain current value. Can be changed via Modbus				
3.3	75	2500	9.6	10.9	21.3	22.6	
2.7	78	2500	10.1	11.4	22.3	23.6	
2.2	81	2500	11.1	12.4	23.3	24.6	
1.8	84	2500	12.1	13.4	24.3	25.6	
1.5	87	2000	Maintain current value. Can be changed via Modbus				
1.0	90	2000	9.6	10.9	21.3	22.6	
0.68	93	2000	10.1	11.4	22.3	23.6	
0.36	96	2000	11.1	12.4	23.3	24.6	
0.051	99	2000	12.1	13.4	24.3	25.6	

Hermetic Compressors for DC Voltage

4.15 Mounting the electronic unit

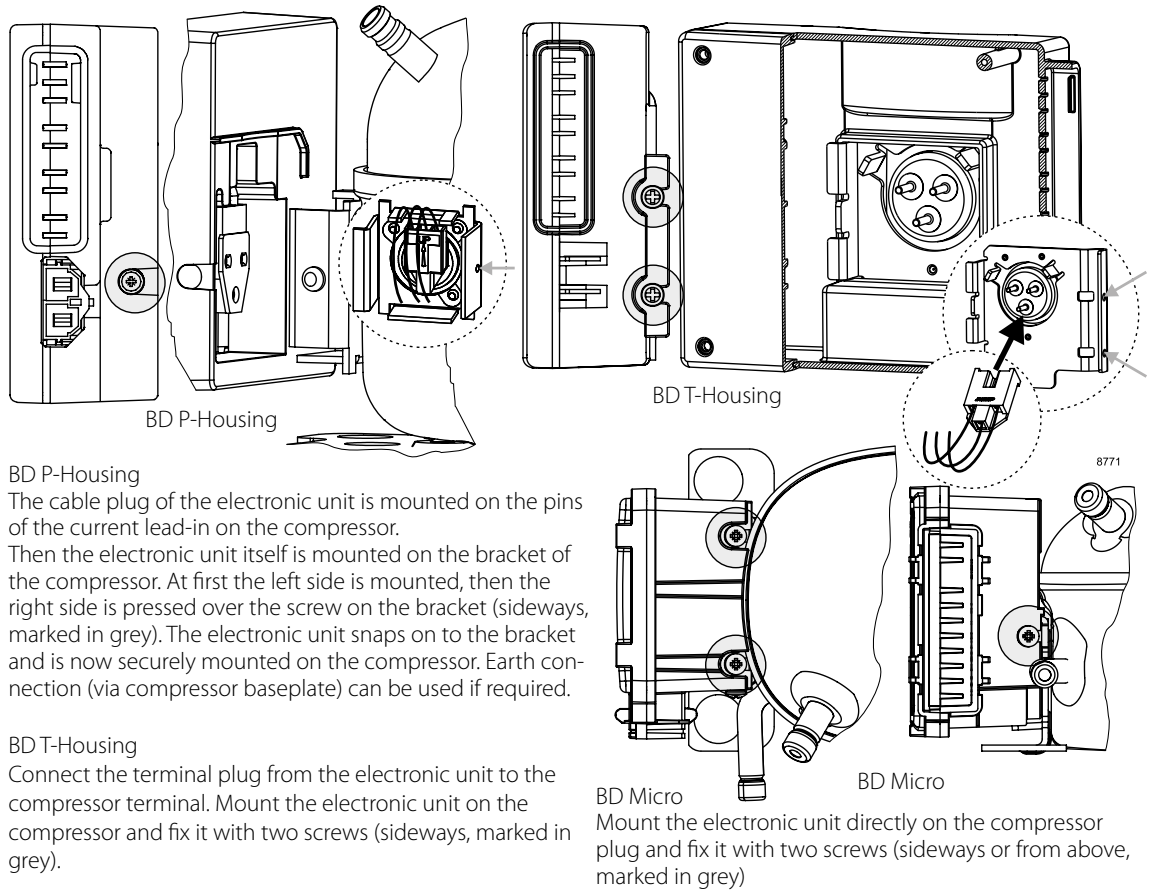

BD P-Housing

The cable plug of the electronic unit is mounted on the pins of the current lead-in on the compressor. Then the electronic unit itself is mounted on the bracket of the compressor. At first the left side is mounted, then the right side is pressed over the screw on the bracket (sideways, marked in grey). The electronic unit snaps on to the bracket and is now securely mounted on the compressor. Earth connection (via compressor baseplate) can be used if required.

BD T-Housing

Connect the terminal plug from the electronic unit to the compressor terminal. Mount the electronic unit on the compressor and fix it with two screws (sideways, marked in grey).

BD Micro

Mount the electronic unit directly on the compressor plug and fix it with two screws (sideways or from above, marked in grey)

4.16 Mounting the remote kit

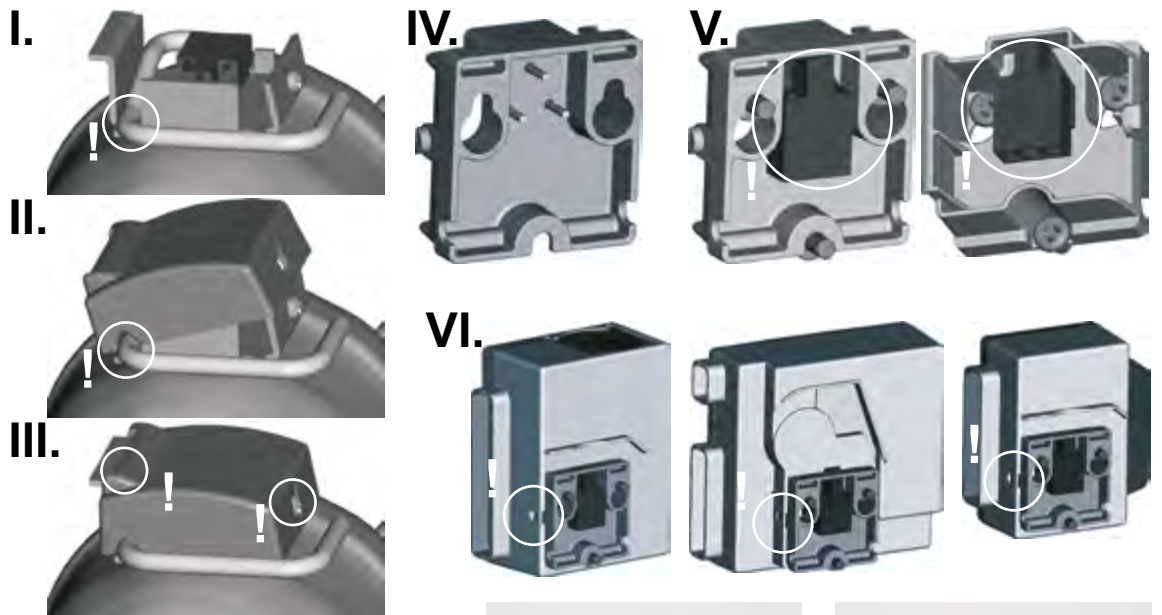

The remote kit was originally designed to be used together with the BD250GH twin compressor. It is applicable to all electronic units used with the BD P-Housing compressor platform. The remote kit supports in mounting the electronic unit in small machine compartments. The electronics unit can be placed next to the compressor.



5. Precondition for long operation life

In order to achieve trouble free operation and long operating life for a hermetic compressor, the following preconditions should be observed:

1. Sufficient starting torque of the compressor motor to allow the motor to start at the pressure conditions in the refrigeration system.
2. Sufficient breakdown torque to allow the motor to handle the load conditions at start up and during operation.
3. When the refrigeration system is in operation, the temperature in the compressor should not rise to levels which could damage its components. Consequently, condensing and compression temperatures should be kept as low as possible.
4. Precise dimensioning of the refrigeration system in question and careful evaluation of the operating conditions of the compressor at expected maximum loads.
5. Sufficient cleanliness and low residual humidity in the circuit.

5.1 Motor overload

Compressor start up is influenced by the starting and/ or breakdown torque of the motor. If starting and/ or breakdown torque is insufficient, the compressor either cannot start or the start will be hampered and delayed because the motor protector is activated. Repeated start attempts subject the motor to overload, which sooner or later will result in failure. Faults of this kind can mostly be avoided by using the correct compressor/ motor combination. Secop compressors produced for Danfoss offers the best solution for nearly all applications. It is a question of selecting the correct compressor for difficult fields of application.

5.2 Thermal overload

Operating conditions resulting in thermal decomposition of the materials used in the compressor must be avoided to ensure long compressor life. The materials relevant in this relation are motor insulation, refrigerant and oil.

The motor insulation consists of the insulating enamel for the copper wires, the slot liner of the stator iron, bandages and feeder cables.

As early as 1960, Secop compressors produced for Danfoss (Danfoss Compressors) introduced fully synthetic insulation materials on all its compressors and the enamel for the wire insulation and the insulating system itself has improved continuously ever since. The result is constantly improved protection against motor overload. Like all other CFC gases, R12 and R502 were found to be harmful to the environment and were consequently prohibited. These refrigerants were used together with mineral oils. A so called Spauschus reaction between oil and refrigerant could consequently occur at high temperatures, which led to valve coking, especially at high residual humidity.

6. Design limits

In order to secure a satisfying lifetime of the compressor, some design criteria for the appliances must be fulfilled. Both the condensing temperature and the compressor temperature should be kept as low as possible. This can be done by using well dimensioned condenser surfaces and by ensuring good ventilation around the compressor under all operating conditions.

In order to protect the compressor against overload, the compressor must start and work properly through pressure peaks obtained in the highest ambient temperature and lowest working voltage. These limitations ensure a protection of valves, gaskets, oil, and motor insulation. Refrigerants R134a, R404A or R507 used today need improved oils. They are only used in connection with special quality polyester oils.

Because of these new oil types and the application of the above mentioned refrigerants there is – in practice – no longer any danger of valve coking. Restrictions on condensing and motor temperatures are now set to protect the motor and thus increase its life.

For the application of Secop compressors produced for Danfoss in household, commercial and mobile refrigeration using the available refrigerants, we recommend the following rules to be observed:

6.1 Coil temperature

Coil temperature must not exceed 125°C during continuous operation.

For limited periods of time, e.g. during compressor start up or in the case of short load peaks, the temperature should not exceed 135°C.

For commercial refrigeration with R134a the same limits as for household refrigeration apply.

However, fan cooling of the compressor is recommended.

6.2 Condensing temperature

When using R600a or R134a the condensing temperature during continuous operation must not exceed 60°C. During limited load peaks the temperature must not exceed 70°C. In commercial refrigeration using R404A and R507 the condensing temperature limit is 48°C during continuous operation and 58°C in the case of load peaks.

7. Moisture and impurities/ filter drier selection

The compressors are dried to a maximum moisture content of 60 to 75 mg depending on the compressor size. The maximum impurity content is 40 to 50 mg depending on the compressor size.

Secop compressors produced for Danfoss leave the factories with a moisture load less or equal 125 ppm. This ppm rate includes a safety factor for a storing time up to one year or longer. In addition of storing time and storing conditions the moisture level will increase. A level between 200 and 250 ppm in general is not critical and will not harm the compressors or systems, where the compressors will be implemented.

Measurement method

Test parameters	Demand
Conditioning	24 h, room temperature
Condition of compressor	charged with oil
Measurement temperature	room temperature
Measurement time	1-2 min
Medium	dew point
Measurement cell	electrical hydrometer
Demand	max.125 ppm H ₂ O

With this measurement method, the total moisture in the air volume will be measured. The water, which is fixed in the plastic structure and the oil, will only be measured indirectly. Within 24 hours equilibrium between the humidity contents of the air and compressor parts is reached. The limit of 125 ppm is very low, if we consider that the surrounding air contains approx. 8000 ppm at 22°C and a relative humidity load of 40 %.

7.1 Filter drier selection

Only filter driers which are declared by the manufacturer to be suitable for mobile applications must be used in refrigeration systems with BD compressors. Filter material powder ending up in the compressor will lead to excessive wear of the piston and transmission parts, and metal particles deposited in the motor windings will cause the compressor to stop because the electric signal back to the electronic unit is disturbed.

The common desiccant is a molecular sieve, a zeolite. For R134a, R404A, R290 and R600a a material with 3 Å pores is recommended, e.g. UOP, XH 9 or XH 11, Grace 594, CECA Siliporite H3R. Pencil driers for R134a can possibly be used for R290, if they are tested according to IEC / EN 60 335 burst pressure demands.

In systems using a TEV valve it can be recommend using a combo drier, which is a drier with a free volume that functions as receiver.

8. Condition at delivery/ warnings

The compressors are delivered without mounted starting devices on pallets. The standard pack can be stacked and is intended for transport by forklift truck. The bottom pallet has the dimensions 1144 x 800mm.

Quantities per pallets are specified in the individual data sheets.
Electrical equipment is packed in separate boxes.

The most important performance controls carried out during manufacturing are,

- A high potential insulation test with 1650V for 1 second
- Pumping capacity
- Tightness of discharge side and discharge valve
- Tightness of compressor housing
- Check of the right oil charge
- Noise test

The compressors are supplied with sealed connectors and the sealing should not be removed before the system assembly takes place. (max. 15 minutes with open connectors).

The compressors are supplied charged with dried and degassed oil, which is normally sufficient for the lifetime of the compressor. The refrigeration systems and the system components must be dimensioned in such a way that the oil can be lead back continuously to the compressor housing without accumulating in the system, e.g. without the oil pockets and with sufficient gas velocity. The compressors use polyolester or mineral oils and are approved only for these oils and for the refrigerant to be used. The oil charge is specified in the individual data sheets.

A high potential test with 1650V for 1 second is carried out on all compressors before delivery. No high potential test or start tests must be carried out while the compressor is under vacuum. No attempt must be made to start the compressor without a complete starting device.

Allow the compressor to reach a temperature above 10°C before starting the first time in order to avoid starting problems.

Anti freeze agents must not be used in the compressors as such agents are damaging to several of the materials used. In particular, the ethyl or methyl alcohol contents of such anti freeze agents have a destructive effect on the synthetic motor insulation

9. Max. refrigerant charge

R134a, R600, R290, and R404A/R507

Only the refrigerant amount which is necessary for the system to function must be charged. The refrigerant amount may be critical, regarding oil foaming and liquid hammer after long standstill periods. Because of this, limitations of refrigerant charges have been introduced.

If the permissible limit of refrigerant charge stated in the compressor data sheet is exceeded the oil will foam in the compressor after a cold start and may result in a damaged valve system in the compressor. The refrigerant charge must never exceed the amount that can be contained in the condenser side of the system.

If these limitations cannot be complied with, the risk may be reduced if a crankcase heater is properly used or if a pump down system is established.

Please refer to the compressor data sheets, as the maximum refrigerant charge may deviate on single types from the statements in the form. The maximum charge of 150g for R600a and R290 is an upper safety limit of the appliance standards, whereas the other weights are stated to avoid liquid hammer.

Compressor type	Max. refrigerant charge			
	R134a	R600a	R290	R404A/R507
BD, P-Housing	300 g	120 g	120 g	-
BD, T-Housing	400 g	-	-	400 g
BD-Micro	150 g	-	-	-

According to the European Standard EN 60335-2-24 or draft IEC 60335-2-89, which must be complied with, the refrigerant charge must not exceed 150g.

Commercially available R600a and R290 must not be used because the fuel grades of these products are of a variable composition. These products may also contain impurities which could significantly reduce the reliability and performance of the system and lead to premature failure. All Secop compressors produced for Danfoss for R600a and R290 are released for a base purity of 97% or better. Impurity limits shall comply with DIN 8960 of 1998 (extended version of ISO 916).

All users of refrigerant R600a should refer to the chemical data safety sheets for full information on the safe handling of R600a and R290.

In general the charge of R600a or R290 is approximately 40-50% by weight than that for HFC.

The refrigerant charge must never be too large to be contained on the condenser side of the refrigeration system. Only the refrigerant amount which is necessary for the system to function must be charged.

10. Conversions

From R12 to alternative refrigerant

As long as new or recycled R12 refrigerant is available this should be used. It is impossible to provide R12 and illegal to use it. It should be thoroughly considered whether repair is worth while. It is hardly worth repairing old small refrigeration systems if it involves replacement of the compressor. Another consideration is use of an alternative refrigerant instead of R12.

From R12 to R134a

Normally, the capillary tube shall be adjusted at low evaporating temperatures. Compared to an optimized R12 system with the same evaporator capacity, the R134a system must have an increased resistance defined as approx. 10% less N^2 flow at 10 bar inlet pressure.

The same size of capillary tube as used for R12 can be used at high evaporating temperatures.

- A drier with 3A desiccant of molecular sieves must always be used.
- Rules for dryness and cleanliness of system components (DIN 8964) are transferred to R134a systems.
- The system components must not contain mineral oil or greasy substances.
- The compressors must be soldered into the system no later than 15 minutes after the connector seals have been removed.
- The same evacuation procedure as for R12 systems must be used.
- Max. 1% non – condensable gases.
- The system must not contain any chlorine.
- The charging equipment must only be used for R134a.
- If the same vacuum pump is to be used for R12 and R134a systems, special Ester oil must be used in agreement with the pump supplier.

From R502 / R22 or R404/R507 to R290

Normally, the same system components can be used as were used with R22. However, an adjustment of the charge must be made. Especially the system design must follow safety standards as EN/ IEC 60335-2-24 or IEC 60335-2-89, EN 378 or national standards.

- A drier with 3A desiccant of molecular sieves or a hardcore drier compatible with R290 must always be used.
- Rules for dryness and cleanliness of system components (DIN 8964) are transferred to R290 systems.
- The compressors must be soldered into the system no later than 15 minutes after the connector seals have been removed.
- The same evacuation procedure as for R22 / R502 / R404A systems must be used.
- Max. 1% non condensable gases.
- The system must not contain chlorine.

From R502 / R22 to R404A/R507 or R407C

Normally, the same system components can be used as were used with R502. However, an adjustment of the charge must be made.

- A drier with 3A desiccant of Molecular Sieves or a hard core drier compatible with R404A must always be used.
- Rules for dryness and cleanliness of system components (DIN 8964) are transferred to R404A systems.
- The system components must not contain mineral oil or greasy substances.
- The compressors must be soldered into the system no later than 15 minutes after the connector seals have been removed.
- The same evacuation procedure as for R502 / R22 systems must be used.
- Max. 1% non condensable gases.
- The system must not contain any chlorine.
- The charging equipment must only be used for R404A/R507 respectively R407C.

11. Mounting the compressor

11.1 Connector positions

Soldering problems caused by oil in the connectors can be avoided by placing the compressor on its base plate some time before soldering it into the system. The compressor must never be placed upside down when mounting the rubber grommets in the base plate. Instead place the compressor on its side with the connectors upwards. The system should be closed within 15 minutes to avoid moisture and dirt penetration.

Tightening torque for M6 bolt joint mountings should be 5 Nm ± 0,5 (hand-tight).

The positions of connectors are found in the sketches. C means suction and must always be connected to the suction line. E means discharge and must be connected to the discharge line. D means process and is used for processing the system.

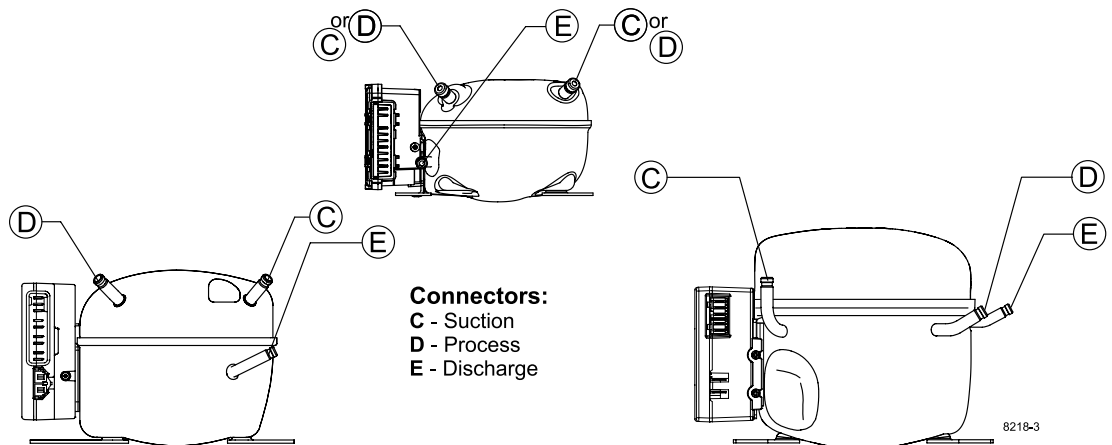

Secop compressors produced for Danfoss are equipped with tube connectors of thick-walled, copper-plated steel tube which have a solderability which comes up to that of conventional copper connectors. The connectors are welded into the compressor housing and weldings cannot be damaged by overheating during soldering.

These copper-plated steel connectors have an aluminium cap sealing which gives a tight sealing. The sealing secures that the compressors have not been opened after leaving Secop compressors produced for Danfoss's production lines. In addition to that, the sealing makes a protecting charge of nitrogen superfluous.

12. Mounting accessories

Mounting	Code number	Bolt / pin dimension	Compressor base hole	Parts list	Type of packaging
Bolt joint	118-1917	M6 metric	16 mm	I	Single pack for one compressor
Bolt joint	118-1918	M6 metric	16 mm	I	Industrial pack in any quantity
Snap-on	118-1947	Ø 7.3 mm	16 mm	II	Single pack for one compressor
Snap-on	118-1919	Ø 7.3 mm	16 mm	II	Industrial pack in any quantity

Parts list	Code number	
I	Sleeve Ø 8 mm x 6.4 mm x 0.8 mm	112-2052
	Washer Ø 20 mm x Ø 6.7 mm x 1 mm	112-2053
	Bolt M6 x 25 mm	681X1130
	Nut M6	118-3659
	Rubber grommet 16 mm	118-3661
II	Steel pin	118-3586
	Washer Ø 21 x Ø 8.1 mm x 0.9 mm	118-3588
	Clip	118-3585
	Rubber Grommet 16 mm	118-3661

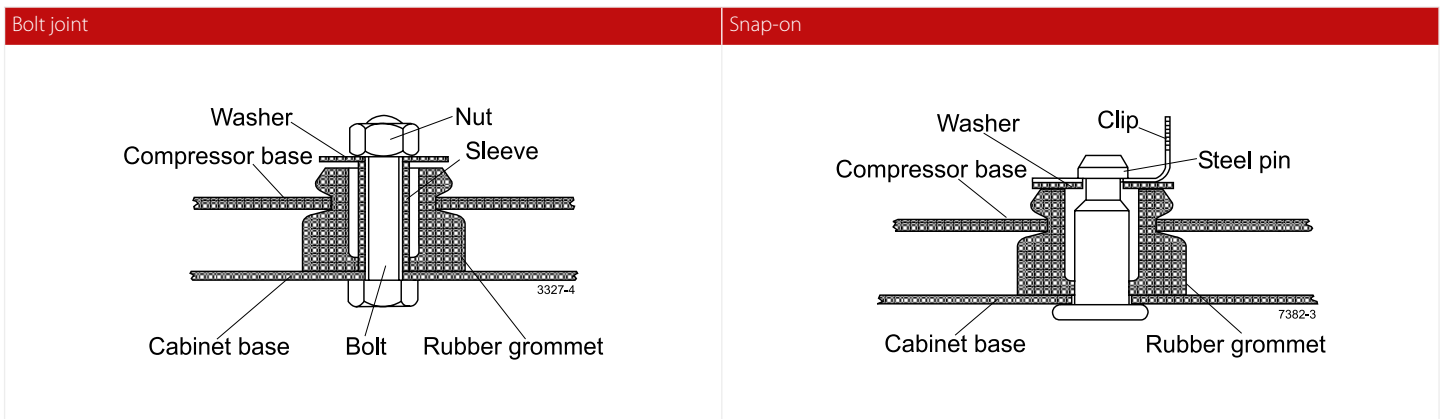

13. Shipment positions

Shipment of refrigeration appliances in horizontal position

When refrigeration appliances are shipped in the normal vertical position, this will normally not cause any damage to the compressor. If transported in horizontal position, the compressor must be oriented as shown in the table on the next page to prevent the accumulation of oil in the muffler and subsequent risk of damage. It is important to note that the compressor must be securely fastened and well supported during transportation.

Refrigeration appliances can be safely transported in horizontal position:

- with trucks on roads and motorways in good condition
- by ship in containers
- on railways in good condition

Compressors Verdichter Compressors	Shipment positions of refrigeration appliances - Position X must not be used				
	Connectors up	Electrical lead-in up	Connectors down	Electrical lead-in down	Base plate up
BD Micro - Series					
BD - Series (P-Housing)					
BD - Series (T-Housing)					

Appendix

Data sheets

R134a:

BD1.4F-AUTO DC Compressor · R134a · 12V DC 70-71
 BD1.4F-FSD DC Compressor · R134a · 12-24V DC · 100-240V AC 50/60Hz 72-73
 BD1.4F-VSD DC Compressor · R134a · 12-24V DC · 100-240V AC 50/60Hz 74-75
 BD1.4F-VSD-HD Heavy Duty DC Compressor · R134a · 12-24V DC 76-77
 BD1.4F-VSD DC Compressor · R134a · 12-24DC V · Inch Connectors · 100-240V AC 50/60Hz 78-79
 BD1.4F-VSD-HD Heavy Duty DC Compressor · R134a · 12-24DC V · Inch Connectors 80-81
 BD35F DC Compressor · R134a · 12-24V DC · 10-45V Solar · 100-240V AC 50/60Hz 82-83
 BD35F DC Compressor · R134a · 12-24V DC · 10-45V Solar · 100-240V AC 50/60Hz · Inch Connectors 84-85
 BD35F-HD Heavy DC Compressor · R134a · 12-24V DC 86-87
 BD35F-B Bus-optimized DC Compressor · R134a · 12-24V DC · 100-240V AC 50/60Hz 88-89
 BD50F DC Compressor · R134a · 12-24V DC · 100-240V AC 50/60Hz 90-91
 BD50F DC Compressor · R134a · 12-24V DC · 100-240V AC 50/60Hz · Inch Connectors 92-93
 BD80F DC Compressor · R134a · 12-24V DC 94-95
 BD150F Variable Speed Drive Compressor · R134a · 160-254V AC 50/60Hz · 12-24V DC with Inverter 96-97
 BD250GH.2 DC Compressor · R134a · 12-24V DC 98-99
 BD250GH.2 DC Compressor · R134a · 48V DC 100-101
 BD350GH DC Compressor · R134a · 12V DC - with 101N08xx Series Controllers 102-103
 BD350GH DC Compressor · R134a · 24V DC - with 101N07xx Series Controllers 104-105
 BD350GH DC Compressor · R134a · 24V DC - with 101N08xx Series Controllers 106-107
 BD350GH DC Compressor · R134a · 48-56V DC 108-109
 BD350/350GH DC Twin Compressor · R134a · 12V DC - with 101N08xx Series Controllers 110-111
 BD350/350GH DC Twin Compressor · R134a · 24V DC - with 101N07xx Series Controllers 112-113
 BD350/350GH DC Twin Compressor · R134a · 24V DC - with 101N08xx Series Controllers 114-115

R600a:

BD35K DC Compressor for Solar Applications · R600a · 10-45V DC 116-117

R290:

BD80CN DC Compressor · R290 · 12-24V DC 118-119
 BD100CN DC Compressor · R290 · 12-24V DC 120-121

R404A/R507:

BD220CL DC Compressor · R404A/R507 · 12V - with 101N08xx Series Controllers 122-123

Cutaway drawing BD35F:

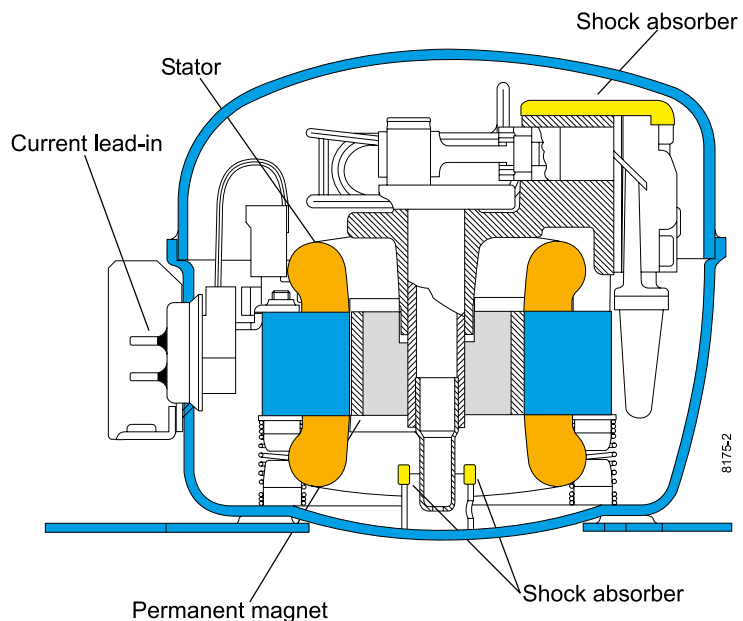



BD1.4F-AUTO Direct Current Compressor R134a 12V DC

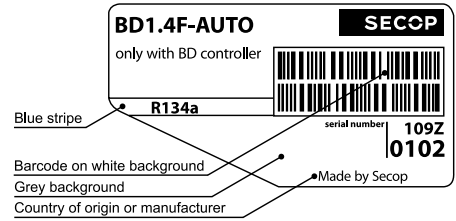

General

Code number (without electronic unit)	109Z0102
Electronic unit - Automotive	101N1010, 30 pcs: 101N1011
Approvals	-
Compressors on pallet	180

Application

Application	LBP/MBP
Evaporating temperature °C	-25 to 5
Voltage range VDC	8.5 - 17
Max. condensing temperature continuous (short) °C	60 (70)
Max. winding temperature continuous (short) °C	125 (135)

Cooling requirements

Application	LBP	MBP	HBP
32°C	S	S	-
38°C	S	S	-
43°C	S	S	-
Remarks on application:			

Motor

Motor type	permanent magnet, brushless DC	
Speed rpm		3,000
Resistance, all 3 windings (25°C) mΩ		370

Design

Displacement cm³	1.41
Oil quantity (type) cm³	75 (polyolester)
Maximum refrigerant charge g	150
Free gas volume in compressor cm³	500
Weight - Compressor/Electronic unit kg	2.1/0.17

Standard battery protection settings (refer to 101N1000 Instructions for optional settings)

Voltage	Min. value	Default	Max. value
Cut out (0.1 steps) VDC	8.5	8.5	17
Cut in diff. (0.1 steps) VDC	0.5	0.5	8

Dimensions

Height	mm	A	96.25
		B	91.25
		B1	88.00
		B2	25.20
Suction connector	location/I.D. mm angle	C	6.2 25°
	material comment		Cu-plated steel Al cap
Process connector	location/I.D. mm angle	D	6.2 25°
	material comment		Cu-plated steel Al cap
Discharge connector	location/I.D. mm angle	E	5.0 0°
	material comment		Cu-plated steel Al cap
Connector tolerance	I.D. mm		±0.09, on 5.0 +0.12/+0.20
Remarks			

- S = Static cooling normally sufficient
- O = Oil cooling
- F₁ = Fan cooling 1.5 m/s
(compressor compartment temperature equal to ambient temperature)
- F₂ = Fan cooling 3.0 m/s necessary
- SG = Suction gas cooling normally sufficient
- = not applicable in this area

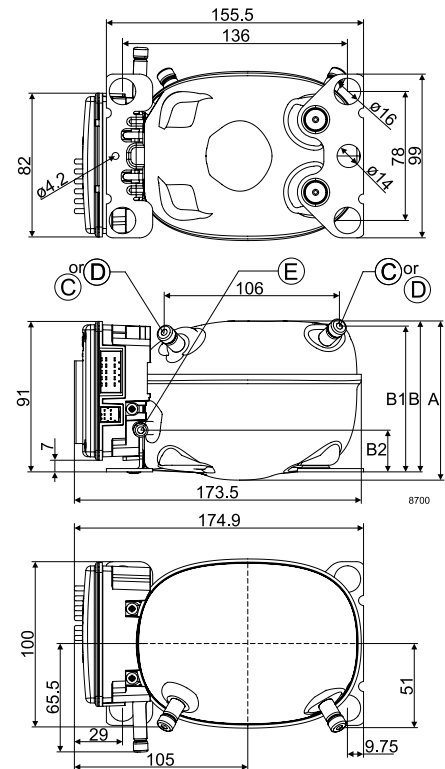

EN 12900 Household (CECOMAF)

Evap. temp. in °C	-25	-23.3	-20	-15	-10	-6.7	-5	0	5
Capacity in W	14.3	17.5	24.3	36.1	50.0	60.5	66.4	85.5	108
Power cons. in W	26.1	27.5	30.3	35.0	40.0	43.4	45.2	50.4	55.6
Current cons. in A	1.98	2.08	2.30	2.65	3.03	3.29	3.42	3.82	4.21
COP in W/W	0.55	0.64	0.80	1.03	1.25	1.39	1.47	1.70	1.94

EN 12900 Household (CECOMAF)

Evap. temp. in °F	-13	-10	0	10	14	20	30	40	41
Capacity in W	14.3	17.5	29.3	43.6	50.0	60.6	81.0	105	108
Power cons. in W	26.1	27.5	32.3	37.7	40.0	43.4	49.3	55.0	55.6
Current cons. in A	1.98	2.08	2.45	2.86	3.03	3.29	3.73	4.17	4.21
COP in W/W	0.55	0.64	0.91	1.15	1.25	1.40	1.64	1.91	1.94

ASHRAE LBP

Evap. temp. in °F	-13	-10	0	10	14	20	30	40	41
Capacity in BTU/h	61.8	75.1	125	185	212	257	344	446	457
Power cons. in W	26.2	27.5	30.3	35.0	39.9	43.4	49.1	54.8	55.3
Current cons. in A	1.98	2.08	2.45	2.86	3.03	3.28	3.72	4.15	4.19
ERR in BTU/h	2.36	2.73	3.86	4.91	5.32	5.94	7.00	8.15	8.27

ASHRAE LBP

Evap. temp. in °C	-25	-23.3	-20	-15	-10	-6.7	-5	0	5
Capacity in W	18.1	22.1	30.5	45.0	62.3	75.3	82.6	106	134
Power cons. in W	26.2	27.5	30.3	35.0	39.9	43.3	45.1	50.3	55.3
Current cons. in A	1.98	2.08	2.30	2.65	3.03	3.28	3.42	3.81	4.19
COP in W/W	0.69	0.80	1.00	1.29	1.56	1.74	1.83	2.12	2.43

Test conditions	EN 12900/CECOMAF	ASHRAE LBP
Condensing temperature	55°C	54.4°C
Ambient temperature	32°C	32°C
Suction gas temperature	32°C	32°C
Liquid temperature	no subcooling	32°C

Operational errors

Error code	Error type
Can be read out in the software TOOL4COOL®	
7	Communication failure
6	Thermostat failure (If the NTC thermistor is short-circuit or has no connection, the electronic unit will enter manual mode).
5	Thermal cut-out of electronic unit (If the refrigeration system has been too heavily loaded, or if the ambient temperature is high, the electronic unit will run too hot).
4	Minimum motor speed error (If the refrigeration system is too heavily loaded, the motor cannot maintain minimum speed at approximately 1,850 rpm).
3	Motor start error (The rotor is blocked or the differential pressure in the refrigeration system is too high (>5 bar)).
2	Fan over-current cut-out (The fan loads the electronic unit with more than 0.65A _{peak}).
1	Battery protection cut-out (The voltage is outside the cut-out setting).

Accessories for BD1.4F-AUTO

Mounting	Code number
Bolt joint for one compressor Ø: 16 mm	118-1917
Bolt joint in quantities Ø: 16 mm	118-1918
Snap-on in quantities Ø: 16 mm	118-1919
One Wire/LIN gateway	105N9501
Not deliverable from Secop	
Automobile fuse DIN 7258	15A

NTC Temperature Sensors Software-Setup

Power: -12V
+
DI KI 31
Dim KI 30
Com KI 15
PWM KI 58s
One Wire LIN Gateway

option 1
option 2
4.7 K
Thermostat
Fan

8704-2

Mechanical Temperature Sensor Hardware-Setup

Power: -12V
+
DI KI 31
Dim KI 30
Com KI 15
PWM KI 58s
One Wire LIN Gateway

Thermostat
316
R1
Fan

MMI:

D1 LED 1 +9°C
D2 LED 2 -3°C
D3 Backlight
Sw1 Switch +9°C
Sw2 Switch -3°C
C Ground

Resistors

Marking	Value [Ω]	Function
R1	see Instructions	battery protection
R2	750	resistor LED 1
R3	750	resistor LED 2
R4	1500	coding resistor S1
R5	330	coding resistor S2

Connectors (Tyco Electronics)

Code no	Male	Female	Crimp
Power	178305-5	178289-5	1-175218-20
MMI	1376136-1	1-1318119-3	1-318108-1

Wire Dimensions DC

Cross section [mm²]	Size		Max. length* 12V operation	
	AWG [Gauge]	[m]	[ft.]	
2.5	12	2.5	8	
4	12	4	13	
6	10	6	20	
10	8	10	33	

*Length between battery and electronic unit



BD1.4F-FSD Direct Current Compressor R134a, 12-24V DC & 100-240V AC 50/60Hz



General

Code number (without electronic unit)	109Z0305
Electronic unit - Fixed Speed	101N2600, 30 pcs: 101N2601
Electronic unit - Fixed Speed w. AC/DC converter	101N5200, 24 pcs: 101N5201
Approvals	VDE, UL, CCC, C-Tick
Compressors on pallet	180

Application

Application	LBP/MBP		
Evaporating temperature	°C	-30 to 0	
Voltage range DC	VDC	9.6 - 17 / 19 - 34	
Voltage range AC	V/Hz	100 - 240 / 50 - 60	
Max. condensing temperature continuous (short)	°C	60 (70)	
Max. winding temperature continuous (short)	°C	125 (135)	

Cooling requirements

Application	LBP	MBP	HBP
32°C	S	S	-
38°C	S	S	-
43°C	S	S	-

Remarks on application:

Motor

Motor type	permanent magnet, brushless DC	
Speed	rpm	3000
Resistance, all 3 windings (25°C)	mΩ	210

Design

Displacement	cm³	1.41
Oil quantity (type)	cm³	75 (polyolester)
Maximum refrigerant charge	g	150
Free gas volume in compressor	cm³	500
Weight - Compressor/Electronic unit	kg	2.1 / 0.11 (DC) / 0.29 (AC/DC)

Standard battery protection settings (refer to 101N2600/5200 Instructions for optional settings)

Voltage (0.1 steps)			Min. value	Default	Max. value
12V	± 0.3V DC, all values	Cut out	VDC 9.6	10.4	17
		Cut in diff.	VDC 0.5	1.3	10
24V	± 0.3V DC, all values	Cut out	VDC 19	21.3	27
		Cut in diff.	VDC 0.5	1.3	10

Dimensions

Height	mm	A	96.25
		B	91.25
		B1	88.00
		B2	25.20
Suction connector	location/I.D. mm angle	C	6.2 25°
	material comment		Cu-plated steel Al cap
Process connector	location/I.D. mm angle	D	6.2 25°
	material comment		Cu-plated steel Al cap
Discharge connector	location/I.D. mm angle	E	5.0 0°
	material comment		Cu-plated steel Al cap
Connector tolerance	I.D. mm		±0.09, on 5.0 +0.12/+0.20

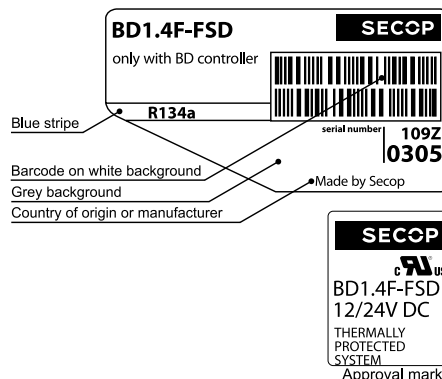

- S = Static cooling normally sufficient
- O = Oil cooling
- F₁ = Fan cooling 1.5 m/s (compressor compartment temperature equal to ambient temperature)
- F₂ = Fan cooling 3.0 m/s necessary
- SG = Suction gas cooling normally sufficient
- = not applicable in this area

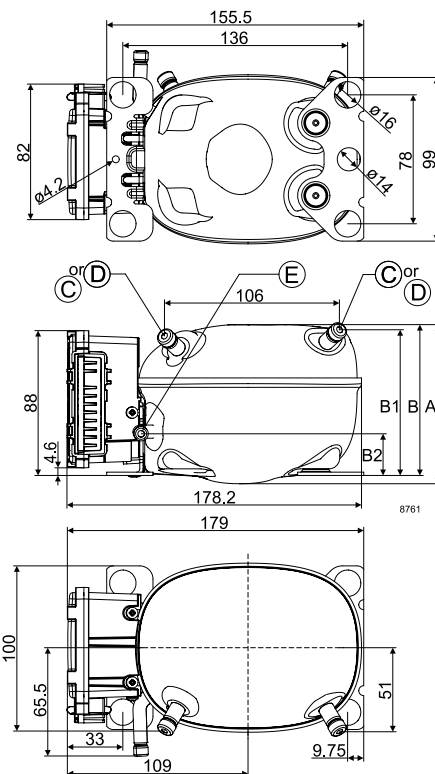

EN 12900 Household (CECOMAF)

Evap. temp. in °C	-30	-25	-23.3	-20	-15	-10	-6.7	-5	0
Capacity in W	4.7	13.2	16.4	23.3	35.2	49.4	60.1	66.0	85.4
Power cons. in W	15.7	22.6	24.8	28.8	34.5	39.6	42.8	44.4	48.7
Current cons. in A	1.30	1.73	1.88	2.16	2.57	2.98	3.24	3.37	3.76
COP in W/W	0.30	0.58	0.66	0.81	1.02	1.25	1.40	1.49	1.75

EN 12900 Household (CECOMAF)

Evap. temp. in °F	-20	-13	-10	0	10	14	20	30	32
Capacity in W	6.5	13.2	16.4	28.3	42.8	49.4	60.2	80.9	85.4
Power cons. in W	17.3	22.6	24.7	31.4	37.4	39.6	42.8	47.8	48.7
Current cons. in A	1.40	1.73	1.88	2.34	2.80	2.98	3.24	3.68	3.76
COP in W/W	0.38	0.58	0.66	0.90	1.14	1.25	1.41	1.69	1.75

ASHRAE LBP

Evap. temp. in °F	-20	-13	-10	0	10	14	20	30	32
Capacity in BTU/h	29.1	57.3	70.7	121.1	182.1	210	256	343	362
Power cons. in W	17.5	22.8	24.9	31.4	37.3	39.5	42.7	47.5	48.4
Current cons. in A	1.41	1.75	1.89	2.35	2.80	2.97	3.24	3.66	3.75
ERR in BTU/h	1.66	2.52	2.84	3.85	4.88	5.31	5.99	7.22	7.48

ASHRAE LBP

Evap. temp. in °C	-30	-25	-23.3	-20	-15	-10	-6.7	-5	0
Capacity in W	6.4	16.8	20.8	29.2	44.0	61.5	74.8	82.2	106
Power cons. in W	16.0	22.8	24.9	28.9	34.5	39.5	42.6	44.2	48.4
Current cons. in A	1.32	1.75	1.89	2.16	2.57	2.97	3.23	3.37	3.75
COP in W/W	0.40	0.74	0.83	1.01	1.28	1.56	1.75	1.86	2.19

Operational errors (TOOL4COOL® or LED flashes)

Error code or LED flashes	Error type
	Can be read out in the software TOOL4COOL®
6	Thermostat failure (If the NTC thermistor is short-circuit or has no connection, the electronic unit will enter manual mode).
5	Thermal cut-out of electronic unit (If the refrigeration system has been too heavily loaded, or if the ambient temperature is high, the electronic unit will run too hot).
4	Minimum motor speed error (If the refrigeration system is too heavily loaded, the motor cannot maintain minimum speed at approximately 1,850 rpm).
3	Motor start error (The rotor is blocked or the differential pressure in the refrigeration system is too high (>5 bar)).
2	Fan over-current cut-out (The fan loads the electronic unit with more than 0.65A _{peak}).
1	Battery protection cut-out (The voltage is outside the cut-out setting).

Wire Dimensions DC

Cross section [mm ²]	Size		Max. length* 12V operation		Max. length* 24V operation	
	AWG	[Gauge]	[m]	[ft.]	[m]	[ft.]
2.5	12		2.5	8	5	16
4	12		4	13	8	26
6	10		6	20	12	39
10	8		10	33	20	66

*Length between battery and electronic unit

Test conditions	EN 12900/CECOMAF	ASHRAE LBP
Condensing temperature	55°C	54.4°C
Ambient temperature	32°C	32°C
Suction gas temperature	32°C	32°C
Liquid temperature	no subcooling	32°C

Accessories for BD1.4F-FSD	Code number
Bolt joint for one compressor	Ø:16 mm 118-1917
Bolt joint in quantities	Ø:16 mm 118-1918
Snap-on in quantities	Ø:16 mm 118-1919
Terminal cover for electronic unit	105N9120
Automobile fuse	12V: 15A Not deliverable from Secop
DIN 7258	24V: 15A
Main switch	min. 20A

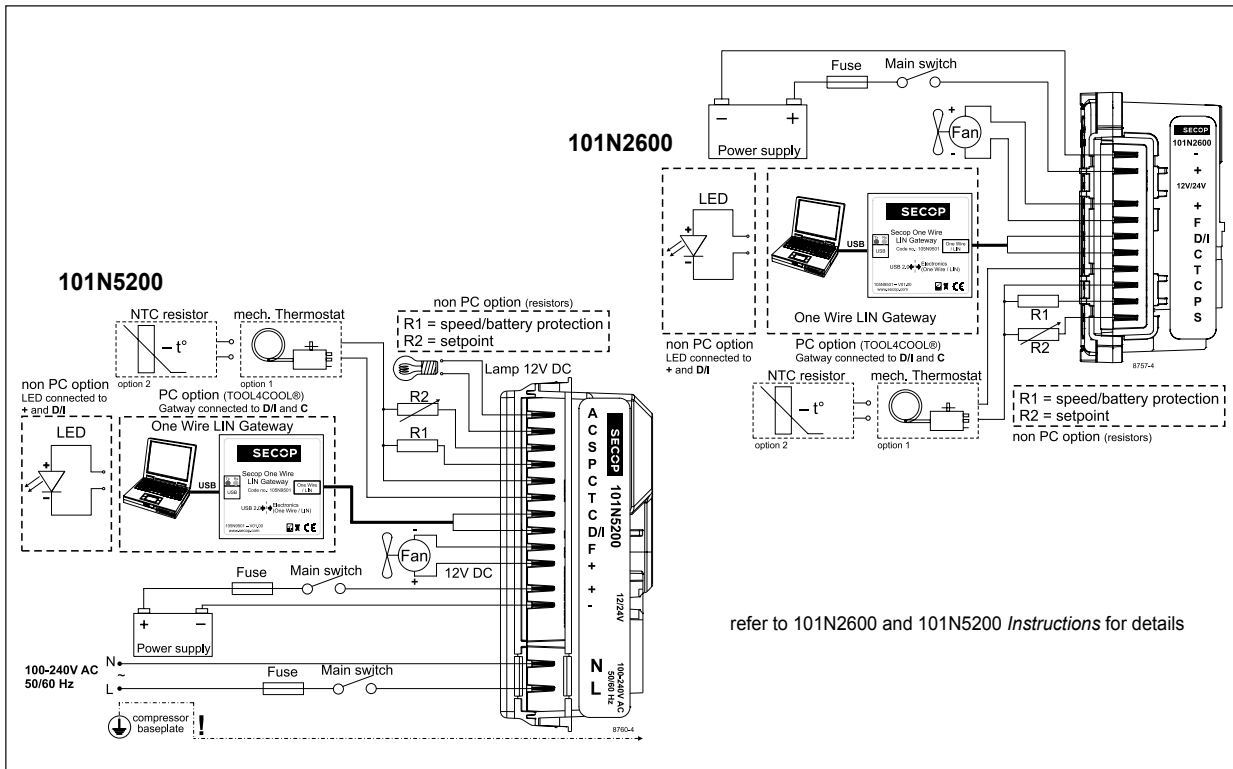

refer to 101N2600 and 101N5200 Instructions for details



BD1.4F-VSD Direct Current Compressor R134a, 12-24V DC & 100-240V AC 50/60Hz



General

Code number (without electronic unit)	109Z0200
Electronic unit - Variable Speed	101N2100, 30 pcs: 101N2101
Electronic unit - Variable Speed w. AC/DC converter	101N5100, 24 pcs: 101N5101
Approvals	VDE, UL, CCC, C-Tick
Compressors on pallet	180

Application

Application	LBP/MBP/HBP		
Evaporating temperature °C	-30 to 15		
Voltage range DC VDC	9.6 - 17 / 19 - 34		
Voltage range AC V/Hz	100 - 240 / 50 - 60		
Max. condensing temperature continuous (short) °C	60 (70)		
Max. winding temperature continuous (short) °C	125 (135)		

Cooling requirements

Application	LBP	MBP	HBP
32°C	S	S	S
38°C	S	S	S
43°C	S	S	S

Remarks on application:

Motor

Motor type	permanet magnet, brushless DC	
Speed rpm	variable speed	
Resistance, all 3 windings (25°C) mΩ	210	

Design

Displacement cm ³	1.41	
Oil quantity (type) cm ³	75 (polyolester)	
Maximum refrigerant charge g	150	
Free gas volume in compressor cm ³	500	
Weight - Compressor/Electronic unit kg	2.1 / 0.11 (DC) / 0.29 (AC/DC)	

Standard battery protection settings (refer to 101N2100/5100 Instructions for optional settings)

Voltage (0.1 steps)			Min. value	Default	Max. value
12V	± 0.3V DC, all values	Cut out VDC	9.6	10.4	17
		Cut in diff. VDC	0.5	1.3	10
24V	± 0.3V DC, all values	Cut out VDC	19	21.3	27
		Cut in diff. VDC	0.5	1.3	10

Dimensions

Height mm	A	96.25
	B	91.25
	B1	88.00
	B2	25.20
Suction connector location/I.D. mm angle	C	6.2 25°
	material comment	Cu-plated steel Al cap
Process connector location/I.D. mm angle	D	6.2 25°
	material comment	Cu-plated steel Al cap
Discharge connector location/I.D. mm angle	E	5.0 0°
	material comment	Cu-plated steel Al cap
Connector tolerance I.D. mm	±0.09, on 5.0 +0.12/+0.20	

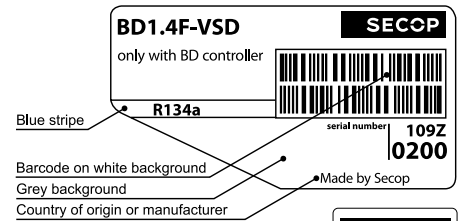

- S = Static cooling normally sufficient
- O = Oil cooling
- F₁ = Fan cooling 1.5 m/s (compressor compartment temperature equal to ambient temperature)
- F₂ = Fan cooling 3.0 m/s necessary
- SG = Suction gas cooling normally sufficient
- = not applicable in this area

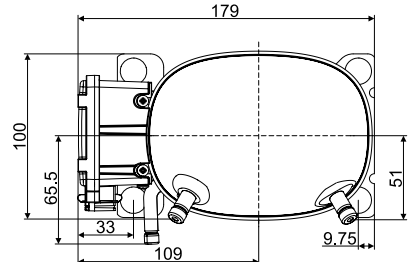
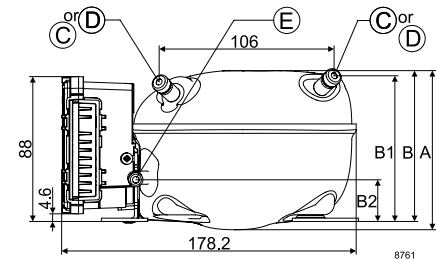
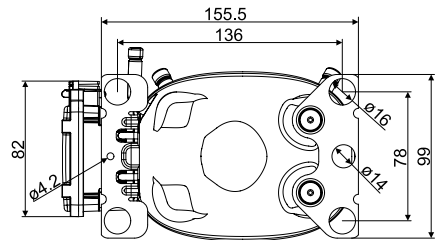



Capacity (EN 12900 Household/CECOMAF) 12V DC, static cooling watt

rpm \ °C	-30	-25	-23.3	-20	-15	-10	-5	0	5	7.2	10	15
2,000		9	11	15	22	31	42	54	69	76	86	106
2,500	7	13	15	20	30	41	55	70	87	96	109	134
3,000	9	16	19	26	37	51	67	85	105	116	131	161
3,500	10	20	23	31	45	61	80	101	124	137	154	190
4,000	12	23	27	36	52	71	92	116	144	158	178	218

Capacity (ASHRAE LBP) 12V DC, static cooling watt

rpm \ °C	-30	-25	-23.3	-20	-15	-10	-5	0	5	7.2	10	15
2,000		12	14	19	28	39	52	68	86	95	107	132
2,500	9	16	19	25	37	51	68	87	109	120	135	167
3,000	11	20	24	32	47	64	84	106	131	144	163	201
3,500	13	24	29	39	56	76	99	125	155	170	192	237
4,000	15	29	34	45	65	88	114	144	179	197	222	272

Power consumption 12V DC, static cooling watt

rpm \ °C	-30	-25	-23.3	-20	-15	-10	-5	0	5	7.2	10	15
2,000		16	17	19	22	25	29	34	40	42	43	45
2,500	16	20	21	24	28	32	37	42	48	50	52	54
3,000	19	24	26	29	34	39	45	50	57	59	61	63
3,500	23	29	31	35	41	47	53	59	66	69	72	77
4,000	27	34	36	41	48	55	61	68	76	79	83	90

Current consumption (for 24V applications the following must be halved) A

rpm \ °C	-30	-25	-23.3	-20	-15	-10	-5	0	5	7.2	10	15
2,000		1.25	1.33	1.48	1.74	2.02	2.32	2.65	2.74	2.85	3.00	3.28
2,500	1.25	1.53	1.63	1.83	2.15	2.48	2.84	3.22	3.69	3.84	4.00	4.20
3,000	1.49	1.84	1.96	2.20	2.59	2.98	3.40	3.82	4.38	4.56	4.77	5.09
3,500	1.77	2.19	2.34	2.63	3.07	3.53	4.00	4.47	5.06	5.26	5.51	5.89
4,000	2.08	2.58	2.75	3.08	3.59	4.10	4.63	5.16	5.87	6.07	6.31	6.63

COP (EN 12900 Household/CECOMAF) 12V DC, static cooling W/W

rpm \ °C	-30	-25	-23.3	-20	-15	-10	-5	0	5	7.2	10	15
2,000		0.59	0.66	0.81	1.03	1.24	1.43	1.60	1.72	1.83	1.99	2.36
2,500	0.43	0.64	0.72	0.86	1.08	1.29	1.48	1.67	1.83	1.94	2.10	2.46
3,000	0.45	0.67	0.74	0.89	1.10	1.30	1.50	1.69	1.84	1.97	2.14	2.54
3,500	0.46	0.68	0.75	0.89	1.10	1.30	1.51	1.70	1.88	1.99	2.15	2.47
4,000	0.45	0.68	0.75	0.89	1.09	1.30	1.50	1.70	1.88	1.99	2.14	2.42

COP (ASHRAE LBP) 12V DC, static cooling W/W

rpm \ °C	-30	-25	-23.3	-20	-15	-10	-5	0	5	7.2	10	15
2,000		0.74	0.83	1.01	1.29	1.55	1.79	2.01	2.17	2.31	2.52	2.98
2,500	0.54	0.80	0.89	1.07	1.34	1.60	1.84	2.08	2.29	2.43	2.64	3.10
3,000	0.57	0.84	0.93	1.11	1.37	1.62	1.87	2.11	2.35	2.47	2.70	3.20
3,500	0.58	0.85	0.94	1.11	1.36	1.62	1.87	2.12	2.36	2.49	2.69	3.11
4,000	0.58	0.85	0.94	1.11	1.36	1.61	1.87	2.12	2.36	2.50	2.68	3.05

Operational errors (TOOL4COOL® or LED flashes)

Error code or LED flashes	Error type
	Can be read out in the software TOOL4COOL®
6	Thermostat failure (If the NTC thermistor is short-circuit or has no connection, the electronic unit will enter manual mode).
5	Thermal cut-out of electronic unit (If the refrigeration system has been too heavily loaded, or if the ambient temperature is high, the electronic unit will run too hot).
4	Minimum motor speed error (If the refrigeration system is too heavily loaded, the motor cannot maintain minimum speed at approximately 1,850 rpm).
3	Motor start error (The rotor is blocked or the differential pressure in the refrigeration system is too high (>5 bar)).
2	Fan over-current cut-out (The fan loads the electronic unit with more than 0.65A _{peak}).
1	Battery protection cut-out (The voltage is outside the cut-out setting).

Wire Dimensions DC

Cross section [mm²]	Size		Max. length* 12V operation		Max. length* 24V operation	
	AWG	[Gauge]	[m]	[ft.]	[m]	[ft.]
2.5	12		2.5	8	5	16
4	12		4	13	8	26
6	10		6	20	12	39
10	8		10	33	20	66

*Length between battery and electronic unit

Accessories for BD1.4F-VSD	Code number
Bolt joint for one compressor Ø:16 mm	118-1917
Bolt joint in quantities Ø:16 mm	118-1918
Snap-on in quantities Ø:16 mm	118-1919
Terminal cover for electronic unit	105N9120
Automobile fuse DIN 7258	12V: 15A 24V: 15A
Main switch	min. 20A Not deliverable from Secop

Test conditions	EN 12900 CECOMAF	ASHRAE LBP
Condensing temperature	55°C	54.4°C
Ambient temperature	32°C	32°C
Suction gas temperature	32°C	32°C
Liquid temperature	no subcooling	32°C

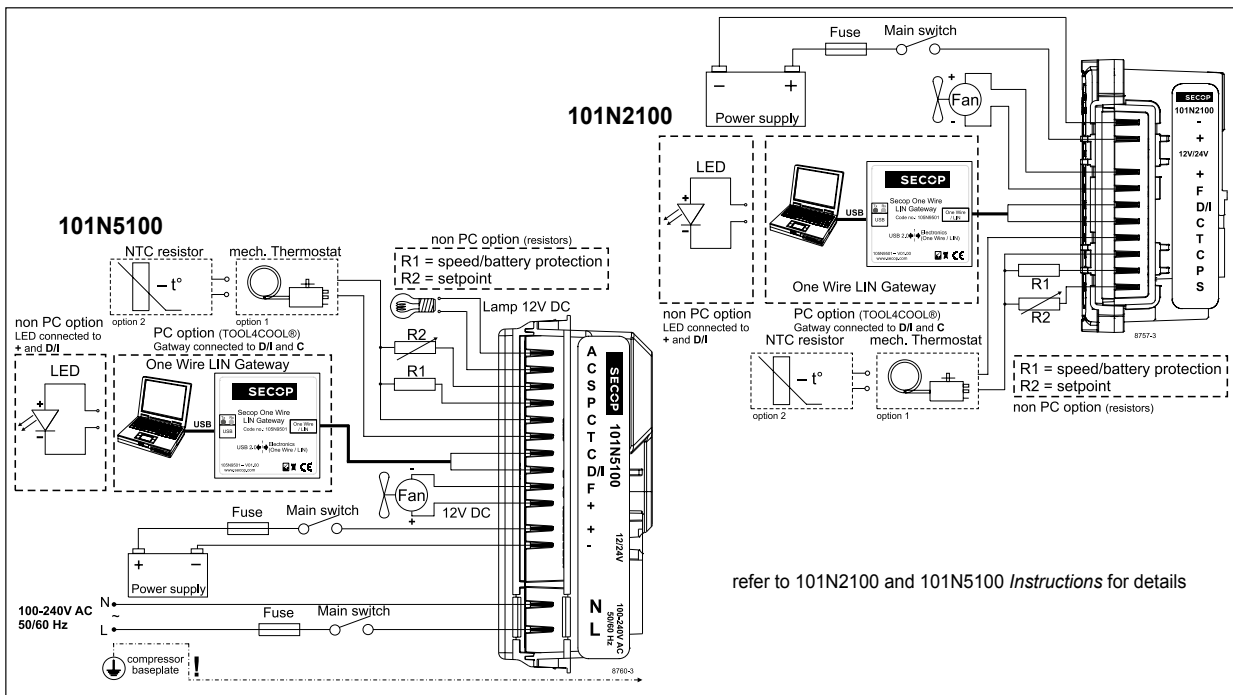

refer to 101N2100 and 101N5100 Instructions for details



BD1.4F-VSD-HD Heavy Duty Direct Current Compressor R134a, 12-24V DC

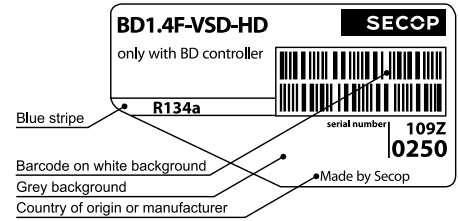

General

Code number (without electronic unit)	109Z0250
Electronic unit - Variable Speed	101N2100, 30 pcs: 101N2101
Approvals	-
Compressors on pallet	180

Application

Application	LBP/MBP/HBP
Evaporating temperature °C	-30 to 15
Voltage range VDC	9.6 - 17 / 19 - 34
Max. condensing temperature continuous (short) °C	60 (70)
Max. winding temperature continuous (short) °C	125 (135)

Cooling requirements

Application	LBP	MBP	HBP
32°C	S	S	S
38°C	S	S	S
43°C	S	S	S

Remarks on application:
HD (Heavy Duty) version of the BD1.4F-VSD which can handle extreme vibrations.
 For more info please contact: mobile@secop.com.

Motor

Motor type	permanent magnet, brushless DC
Speed rpm	variable speed
Resistance, all 3 windings (25°C) mΩ	210

Design

Displacement cm ³	1.41
Oil quantity (type) cm ³	75 (polyolester)
Maximum refrigerant charge g	150
Free gas volume in compressor cm ³	500
Weight - Compressor/Electronic unit kg	2.1/0.11

Standard battery protection settings (refer to 101N2100 Instructions for optional settings)

Voltage (0.1 steps)		Min. value	Default	Max. value
12V	± 0.3V DC, all values	9.6	10.4	17
	Cut out VDC			
24V	± 0.3V DC, all values	19	21.3	27
	Cut in diff. VDC			

Dimensions

Height	mm	A	96.25
		B	91.25
		B1	88.00
		B2	25.20
Suction connector	location/I.D. mm angle	C	6.2 25°
	material comment		Cu-plated steel Al cap
Process connector	location/I.D. mm angle	D	6.2 25°
	material comment		Cu-plated steel Al cap
Discharge connector	location/I.D. mm angle	E	5.0 0°
	material comment		Cu-plated steel Al cap
Connector tolerance	I.D. mm		±0.09, on 5.0 +0.12/+0.20

- S = Static cooling normally sufficient
- O = Oil cooling
- F₁ = Fan cooling 1.5 m/s
(compressor compartment temperature equal to ambient temperature)
- F₂ = Fan cooling 3.0 m/s necessary
- SG = Suction gas cooling normally sufficient
- = not applicable in this area

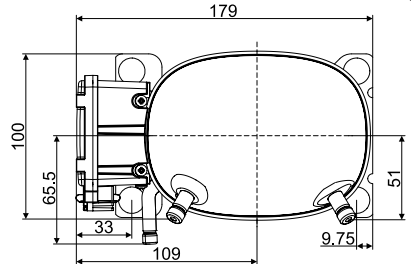
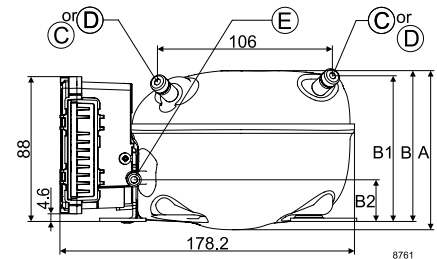
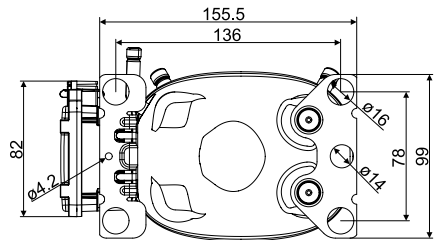

Capacity (EN 12900 Household/CECOMAF) 12V DC, static cooling **watt**

rpm \ °C	-30	-25	-23.3	-20	-15	-10	-5	0	5	7.2	10	15
2,000		9	11	15	22	31	42	54	69	76	86	106
2,500	7	13	15	20	30	41	55	70	87	96	109	134
3,000	9	16	19	26	37	51	67	85	105	116	131	161
3,500	10	20	23	31	45	61	80	101	124	137	154	190
4,000	12	23	27	36	52	71	92	116	144	158	178	218

Capacity (ASHRAE LBP) 12V DC, static cooling **watt**

rpm \ °C	-30	-25	-23.3	-20	-15	-10	-5	0	5	7.2	10	15
2,000		12	14	19	28	39	52	68	86	95	107	132
2,500	9	16	19	25	37	51	68	87	109	120	135	167
3,000	11	20	24	32	47	64	84	106	131	144	163	201
3,500	13	24	29	39	56	76	99	125	155	170	192	237
4,000	15	29	34	45	65	88	114	144	179	197	222	272

Power consumption 12V DC, static cooling **watt**

rpm \ °C	-30	-25	-23.3	-20	-15	-10	-5	0	5	7.2	10	15
2,000		16	17	19	22	25	29	34	40	42	43	45
2,500	16	20	21	24	28	32	37	42	48	50	52	54
3,000	19	24	26	29	34	39	45	50	57	59	61	63
3,500	23	29	31	35	41	47	53	59	66	69	72	77
4,000	27	34	36	41	48	55	61	68	76	79	83	90

Current consumption (for 24V applications the following must be halved) **A**

rpm \ °C	-30	-25	-23.3	-20	-15	-10	-5	0	5	7.2	10	15
2,000		1.25	1.33	1.48	1.74	2.02	2.32	2.65	2.74	2.85	3.00	3.28
2,500	1.25	1.53	1.63	1.83	2.15	2.48	2.84	3.22	3.69	3.84	4.00	4.20
3,000	1.49	1.84	1.96	2.20	2.59	2.98	3.40	3.82	4.38	4.56	4.77	5.09
3,500	1.77	2.19	2.34	2.63	3.07	3.53	4.00	4.47	5.06	5.26	5.51	5.89
4,000	2.08	2.58	2.75	3.08	3.59	4.10	4.63	5.16	5.87	6.07	6.31	6.63

COP (EN 12900 Household/CECOMAF) 12V DC, static cooling **W/W**

rpm \ °C	-30	-25	-23.3	-20	-15	-10	-5	0	5	7.2	10	15
2,000		0.59	0.66	0.81	1.03	1.24	1.43	1.60	1.72	1.83	1.99	2.36
2,500	0.43	0.64	0.72	0.86	1.08	1.29	1.48	1.67	1.83	1.94	2.10	2.46
3,000	0.45	0.67	0.74	0.89	1.10	1.30	1.50	1.69	1.84	1.97	2.14	2.54
3,500	0.46	0.68	0.75	0.89	1.10	1.30	1.51	1.70	1.88	1.99	2.15	2.47
4,000	0.45	0.68	0.75	0.89	1.09	1.30	1.50	1.70	1.88	1.99	2.14	2.42

COP (ASHRAE LBP) 12V DC, static cooling **W/W**

rpm \ °C	-30	-25	-23.3	-20	-15	-10	-5	0	5	7.2	10	15
2,000		0.74	0.83	1.01	1.29	1.55	1.79	2.01	2.17	2.31	2.52	2.98
2,500	0.54	0.80	0.89	1.07	1.34	1.60	1.84	2.08	2.29	2.43	2.64	3.10
3,000	0.57	0.84	0.93	1.11	1.37	1.62	1.87	2.11	2.35	2.47	2.70	3.20
3,500	0.58	0.85	0.94	1.11	1.36	1.62	1.87	2.12	2.36	2.49	2.69	3.11
4,000	0.58	0.85	0.94	1.11	1.36	1.61	1.87	2.12	2.36	2.50	2.68	3.05

Operational errors (TOOL4COOL® or LED flashes)

Error code or LED flashes	Error type
	Can be read out in the software TOOL4COOL®
6	Thermostat failure (If the NTC thermistor is short-circuit or has no connection, the electronic unit will enter manual mode).
5	Thermal cut-out of electronic unit (If the refrigeration system has been too heavily loaded, or if the ambient temperature is high, the electronic unit will run too hot).
4	Minimum motor speed error (If the refrigeration system is too heavily loaded, the motor cannot maintain minimum speed at approximately 1,850 rpm).
3	Motor start error (The rotor is blocked or the differential pressure in the refrigeration system is too high (>5 bar)).
2	Fan over-current cut-out (The fan loads the electronic unit with more than 0.65A _{peak}).
1	Battery protection cut-out (The voltage is outside the cut-out setting).

Wire Dimensions DC

Size	Max. length* 12V operation		Max. length* 24V operation		
	AWG	[m]	[ft.]	[m]	[ft.]
2.5	12	2.5	8	5	16
4	12	4	13	8	26
6	10	6	20	12	39
10	8	10	33	20	66

*Length between battery and electronic unit

Accessories for BD1.4F-VSD-HD	Code number
Bolt joint for one compressor	Ø:16 mm 118-1917
Bolt joint in quantities	Ø:16 mm 118-1918
Snap-on in quantities	Ø:16 mm 118-1919
Terminal cover for electronic unit	105N9120
Automobile fuse	12V: 15A Not deliverable
DIN 7258	24V: 15A
Main switch	min. 20A from Secop

Test conditions	EN 12900 CECOMAF	ASHRAE LBP
Condensing temperature	55°C	54.4°C
Ambient temperature	32°C	32°C
Suction gas temperature	32°C	32°C
Liquid temperature	no subcooling	32°C

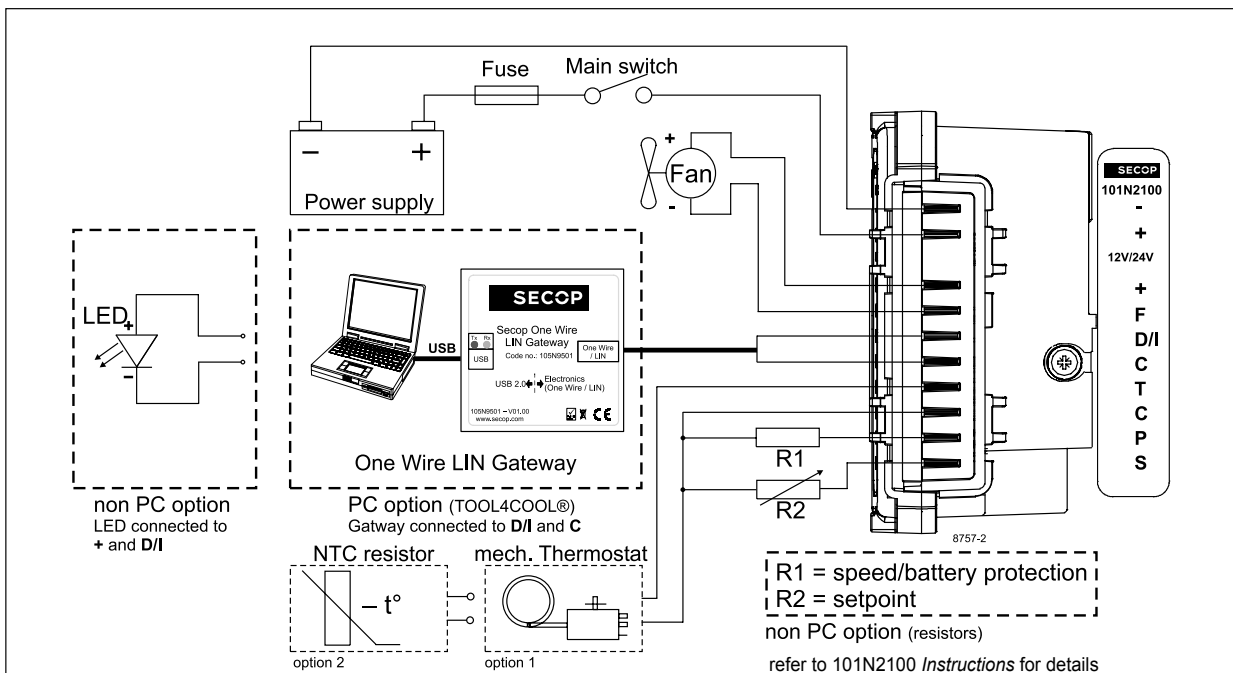



BD1.4F-VSD Direct Current Compressor R134a, 12-24V DC & 100-240V AC 50/60Hz



General

Code number (without electronic units)	109Z0202
Electronic unit - Variable Speed	101N2100, 30 pcs: 101N2101
Electronic unit - Variable Speed w. AC/DC converter	101N5100, 24 pcs: 101N5101
Approvals	VDE, UL, CCC, C-Tick
Compressors on pallet	180

Application

Application	LBP/MBP/HBP
Evaporating temperature °F	-20 to 59
Voltage range DC VDC	9.6 - 17 / 19 - 34
Voltage range AC V/Hz	100 - 240 / 50 - 60
Max. condensing temperature continuous (short) °F	140 (158)
Max. winding temperature continuous (short) °F	257 (275)

Cooling requirements

Application	LBP	MBP	HBP
32°C	S	S	S
38°C	S	S	S
43°C	S	S	S

Motor

Motor type	permanet magnet, brushless DC
Speed	variable speed
Resistance, all 3 windings (25°C) mΩ	210

Design

Displacement cu.in.	0.086
Oil quantity (type) fl.oz.	2.64 (polyolester)
Maximum refrigerant charge oz.	5.29
Free gas volume in compressor fl.oz.	17.60
Weight - Compressor/Electronic unit lbs.	4.63 / 0.24 (DC) / 0.64 (AC/DC)

Standard battery protection settings (refer to 101N2100/5100 Instructions for optional settings)

Voltage (0.1 steps)			Min. value	Default	Max. value
12V	± 0.3V DC, all values	Cut out VDC	9.6	10.4	17
		Cut in diff. VDC	0.5	1.3	10
24V	± 0.3V DC, all values	Cut out VDC	19	21.3	27
		Cut in diff. VDC	0.5	1.3	10

Dimensions

Height	inch	A	3.79
		B	3.59
		B1	3.46
		B2	0.99
Suction connector	location/I.D. inch angle	C	0.252-0.259 25°
	material comment		Cu-plated steel Al cap
Process connector	location/I.D. inch angle	D	0.252-0.259 25°
	material comment		Cu-plated steel Al cap
Discharge connector	location/I.D. inch angle	E	0.202-0.205 0°
	material comment		Cu-plated steel Al cap
Remarks: inch connectors			

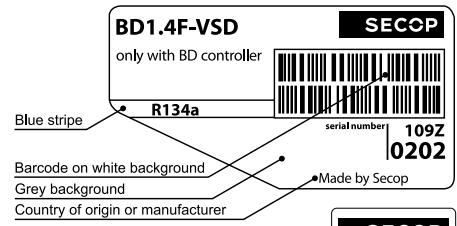

- S = Static cooling normally sufficient
- O = Oil cooling
- F₁ = Fan cooling 1.5 m/s (compressor compartment temperature equal to ambient temperature)
- F₂ = Fan cooling 3.0 m/s necessary
- SG = Suction gas cooling normally sufficient
- = not applicable in this area

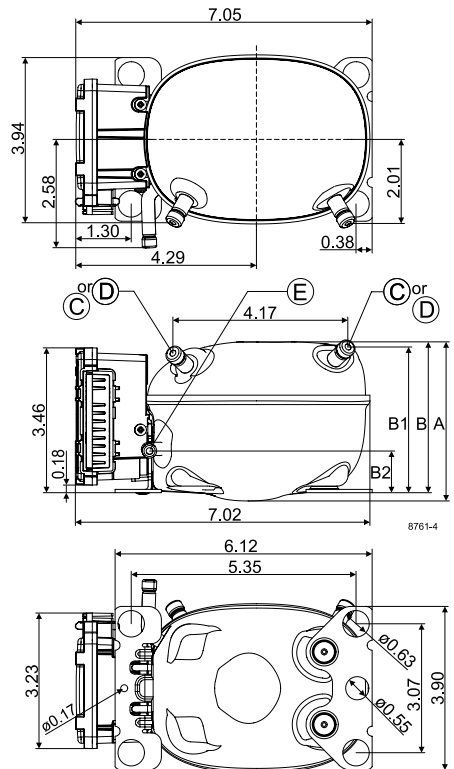

Capacity (ASHRAE LBP) 12V DC, static cooling **BTU/h**

rpm \ °F	-20	-13	-10	0	10	14	20	30	41	45	50	59
2,000		41	48	78	115	133	162	218	294	325	366	450
2,500	32	57	67	107	154	175	210	278	370	409	461	569
3,000	52	80	92	138	192	216	257	337	447	493	556	685
3,500	51	89	106	164	229	258	306	400	528	582	656	809
4,000	67	105	122	185	260	295	352	462	611	673	757	928

Capacity (EN 12900 Household/CECOMAF) 12V DC, static cooling **watt**

rpm \ °F	-20	-13	-10	0	10	14	20	30	41	45	50	59
2,000		10	12	19	28	32	39	52	70	77	87	107
2,500	9	16	19	31	45	51	61	80	105	116	130	159
3,000	14	22	26	39	55	62	74	97	127	140	157	192
3,500	11	24	30	48	68	76	90	116	149	163	181	219
4,000	21	32	36	54	75	85	100	130	170	186	209	253

Power consumption 12V DC, static cooling **watt**

rpm \ °F	-20	-13	-10	0	10	14	20	30	41	45	50	59
2,000		14	15	19	24	26	29	35	40	41	43	44
2,500	19	21	22	25	29	31	34	38	42	43	44	45
3,000	22	24	26	30	36	38	41	46	51	52	53	54
3,500	25	29	31	37	44	46	50	55	60	62	63	65
4,000	31	36	38	45	51	53	57	63	69	71	74	79

Current consumption (for 24V applications the following must be halved) **A**

rpm \ °F	-20	-13	-10	0	10	14	20	30	41	45	50	59
2,000		1.31	1.39	1.65	1.90	2.00	2.15	2.41	2.71	2.82	2.96	3.23
2,500	1.51	1.62	1.68	1.95	2.28	2.42	2.63	2.96	3.25	3.33	3.40	3.45
3,000	1.78	1.97	2.06	2.40	2.76	2.91	3.14	3.49	3.82	3.92	4.03	4.17
3,500	1.95	2.25	2.38	2.85	3.32	3.51	3.78	4.20	4.58	4.69	4.81	4.95
4,000	3.17	3.24	3.29	3.56	3.93	4.11	4.38	4.86	5.37	5.55	5.75	6.05

EER (ASHRAE LBP) 12V DC, static cooling **BTU/h**

rpm \ °F	-20	-13	-10	0	10	14	20	30	41	45	50	59
2,000		2.88	3.19	4.06	4.78	5.06	5.49	6.29	7.39	7.88	8.58	10.17
2,500	1.88	2.95	3.33	4.32	5.09	5.38	5.83	6.66	7.79	8.29	9.00	10.57
3,000	2.73	3.55	3.82	4.54	5.16	5.42	5.84	6.68	7.89	8.43	9.19	10.90
3,500	2.09	3.14	3.49	4.42	5.18	5.49	5.96	6.84	8.01	8.50	9.18	10.60
4,000	2.36	3.09	3.36	4.19	5.00	5.34	5.87	6.83	8.03	8.51	9.15	10.40

COP (EN 12900 Household/CECOMAF) 12V DC, static cooling **W/W**

rpm \ °F	-20	-13	-10	0	10	14	20	30	41	45	50	59
2,000		0.69	0.77	0.97	1.14	1.21	1.31	1.50	1.76	1.88	2.04	2.42
2,500	0.45	0.77	0.89	1.23	1.52	1.62	1.79	2.09	2.50	2.68	2.94	3.53
3,000	0.62	0.90	1.00	1.29	1.54	1.64	1.80	2.10	2.52	2.70	2.96	3.55
3,500	0.46	0.83	0.96	1.29	1.56	1.66	1.81	2.10	2.48	2.64	2.87	3.35
4,000	0.67	0.88	0.96	1.21	1.48	1.58	1.76	2.07	2.46	2.61	2.82	3.22

Operational errors (TOOL4COOL® or LED flashes)

Error code or LED flashes	Error type
	Can be read out in the software TOOL4COOL®
6	Thermostat failure (If the NTC thermistor is short-circuit or has no connection, the electronic unit will enter manual mode).
5	Thermal cut-out of electronic unit (If the refrigeration system has been too heavily loaded, or if the ambient temperature is high, the electronic unit will run too hot).
4	Minimum motor speed error (If the refrigeration system is too heavily loaded, the motor cannot maintain minimum speed at approximately 1.850 rpm).
3	Motor start error (The rotor is blocked or the differential pressure in the refrigeration system is too high (>5 bar)).
2	Fan over-current cut-out (The fan loads the electronic unit with more than 0.65A _{peak}).
1	Battery protection cut-out (The voltage is outside the cut-out setting).

Wire Dimensions DC

Cross section [mm ²]	Size AWG [Gauge]	Max. length* 12V operation		Max. length* 24V operation	
		[m]	[ft.]	[m]	[ft.]
2.5	12	2.5	8	5	16
4	12	4	13	8	26
6	10	6	20	12	39
10	8	10	33	20	66

*Length between battery and electronic unit

Accessories for BD1.4F-VSD	Code number
Bolt joint for one compressor	Ø:16 mm 118-1917
Bolt joint in quantities	Ø:16 mm 118-1918
Snap-on in quantities	Ø:16 mm 118-1919
Terminal cover for electronic unit	105N9120
Automobile fuse DIN 7258	12V: 15A 24V: 15A
Main switch	min. 20A Not deliverable from Secop

Test conditions	EN 12900 CECOMAF	ASHRAE LBP
Condensing temperature	131°F	130°F
Ambient temperature	90°F	90°F
Suction gas temperature	90°F	90°F
Liquid temperature	no subcooling	90°F

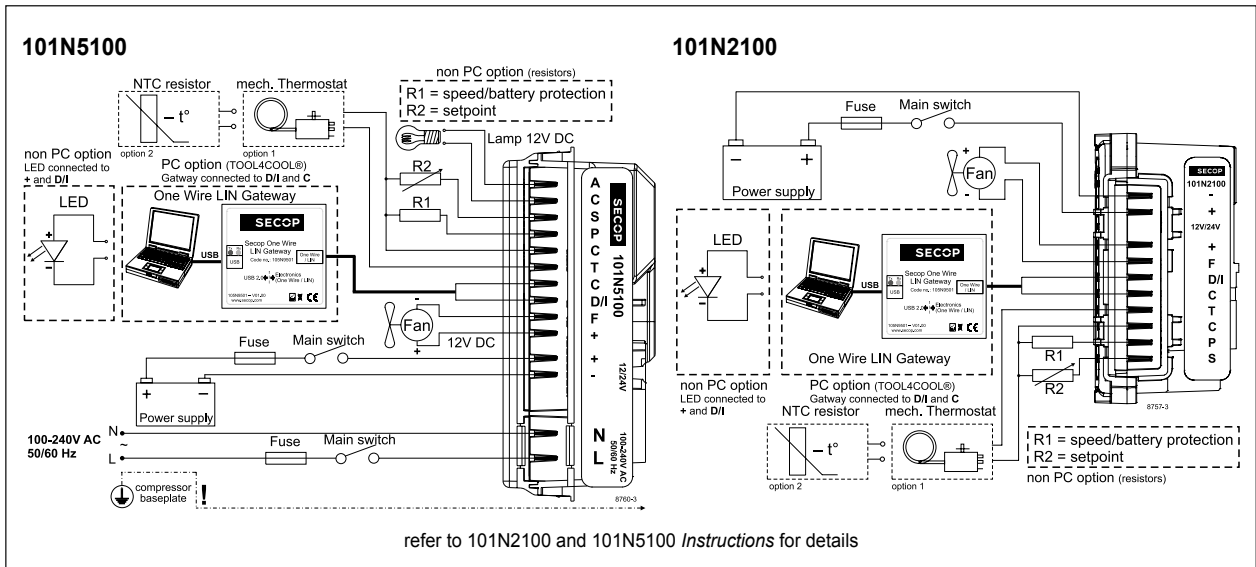



BD1.4F-VSD-HD Heavy Duty Direct Current Compressor R134a, 12-24V DC



General

Code number (without electronic units)	109Z0251
Electronic unit - Variable Speed	101N2100, 30 pcs: 101N2101
Approvals	-
Compressors on pallet	180

Application

Application	LBP/MBP/HBP
Evaporating temperature °F	-20 to 59
Voltage range VDC	9.6 - 17 / 19 - 34
Max. condensing temperature continuous (short) °F	140 (158)
Max. winding temperature continuous (short) °F	257 (275)

Cooling requirements

Application	LBP	MBP	HBP
32°C	S	S	S
38°C	S	S	S
43°C	S	S	S

Remarks on application:
HD (Heavy Duty) version of the BD1.4F-VSD which can handle extreme vibrations.
 For more info please contact: mobile@secop.com.

Motor

Motor type	permanet magnet, brushless DC
Speed	variable speed
Resistance, all 3 windings (25°C) mΩ	210

Design

Displacement cu.in.	0.086
Oil quantity (type) fl.oz.	2.64 (polyolester)
Maximum refrigerant charge oz.	5.29
Free gas volume in compressor fl.oz.	17.60
Weight - Compressor/Electronic unit lbs.	4.63/0.24

Standard battery protection settings (refer to 101N2100 Instructions for optional settings)

Voltage (0.1 steps)			Min. value	Default	Max. value
12V	± 0.3V DC, all values	Cut out VDC	9.6	10.4	17
		Cut in diff. VDC	0.5	1.3	10
24V	± 0.3V DC, all values	Cut out VDC	19	21.3	27
		Cut in diff. VDC	0.5	1.3	10

Dimensions

Height	inch	A	3.79
		B	3.59
		B1	3.46
		B2	0.99
Suction connector	location/I.D. inch angle	C	0.252-0.259 25°
	material comment		Cu-plated steel Al cap
Process connector	location/I.D. inch angle	D	0.252-0.259 25°
	material comment		Cu-plated steel Al cap
Discharge connector	location/I.D. inch angle	E	0.202-0.205 0°
	material comment		Cu-plated steel Al cap

Remarks: **inch connectors**

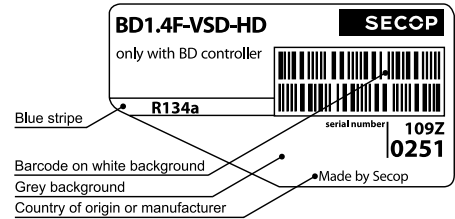

- S = Static cooling normally sufficient
- O = Oil cooling
- F₁ = Fan cooling 1.5 m/s (compressor compartment temperature equal to ambient temperature)
- F₂ = Fan cooling 3.0 m/s necessary
- SG = Suction gas cooling normally sufficient
- = not applicable in this area

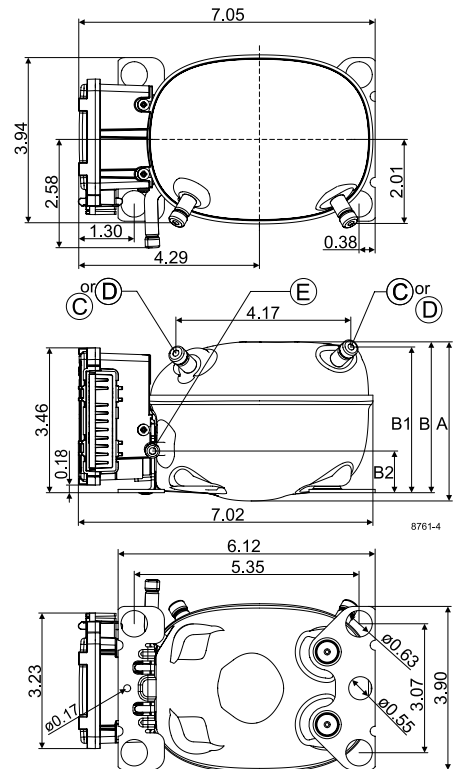

Capacity (ASHRAE LBP) 12V DC, static cooling **BTU/h**

rpm \ °F	-20	-13	-10	0	10	14	20	30	41	45	50	59
2,000	41	48	78	115	133	162	218	294	325	366	450	
2,500	32	57	67	107	154	175	210	278	370	409	461	569
3,000	52	80	92	138	192	216	257	337	447	493	556	685
3,500	51	89	106	164	229	258	306	400	528	582	656	809
4,000	67	105	122	185	260	295	352	462	611	673	757	928

Capacity (EN 12900 Household/CECOMAF) 12V DC, static cooling **watt**

rpm \ °F	-20	-13	-10	0	10	14	20	30	41	45	50	59
2,000	10	12	19	28	32	39	52	70	77	87	107	
2,500	9	16	19	31	45	51	61	80	105	116	130	159
3,000	14	22	26	39	55	62	74	97	127	140	157	192
3,500	11	24	30	48	68	76	90	116	149	163	181	219
4,000	21	32	36	54	75	85	100	130	170	186	209	253

Power consumption 12V DC, static cooling **watt**

rpm \ °F	-20	-13	-10	0	10	14	20	30	41	45	50	59
2,000	14	15	19	24	26	29	35	40	41	43	44	
2,500	19	21	22	25	29	31	34	38	42	43	44	45
3,000	22	24	26	30	36	38	41	46	51	52	53	54
3,500	25	29	31	37	44	46	50	55	60	62	63	65
4,000	31	36	38	45	51	53	57	63	69	71	74	79

Current consumption (for 24V applications the following must be halved) **A**

rpm \ °F	-20	-13	-10	0	10	14	20	30	41	45	50	59
2,000	1.31	1.39	1.65	1.90	2.00	2.15	2.41	2.71	2.82	2.96	3.23	
2,500	1.51	1.62	1.68	1.95	2.28	2.42	2.63	2.96	3.25	3.33	3.40	3.45
3,000	1.78	1.97	2.06	2.40	2.76	2.91	3.14	3.49	3.82	3.92	4.03	4.17
3,500	1.95	2.25	2.38	2.85	3.32	3.51	3.78	4.20	4.58	4.69	4.81	4.95
4,000	3.17	3.24	3.29	3.56	3.93	4.11	4.38	4.86	5.37	5.55	5.75	6.05

EER (ASHRAE LBP) 12V DC, static cooling **BTU/h**

rpm \ °F	-20	-13	-10	0	10	14	20	30	41	45	50	59
2,000	2.88	3.19	4.06	4.78	5.06	5.49	6.29	7.39	7.88	8.58	10.17	
2,500	1.88	2.95	3.33	4.32	5.09	5.38	5.83	6.66	7.79	8.29	9.00	10.57
3,000	2.73	3.55	3.82	4.54	5.16	5.42	5.84	6.68	7.89	8.43	9.19	10.90
3,500	2.09	3.14	3.49	4.42	5.18	5.49	5.96	6.84	8.01	8.50	9.18	10.60
4,000	2.36	3.09	3.36	4.19	5.00	5.34	5.87	6.83	8.03	8.51	9.15	10.40

COP (EN 12900 Household/CECOMAF) 12V DC, static cooling **W/W**

rpm \ °F	-20	-13	-10	0	10	14	20	30	41	45	50	59
2,000	0.69	0.77	0.97	1.14	1.21	1.31	1.50	1.76	1.88	2.04	2.42	
2,500	0.45	0.77	0.89	1.23	1.52	1.62	1.79	2.09	2.50	2.68	2.94	3.53
3,000	0.62	0.90	1.00	1.29	1.54	1.64	1.80	2.10	2.52	2.70	2.96	3.55
3,500	0.46	0.83	0.96	1.29	1.56	1.66	1.81	2.10	2.48	2.64	2.87	3.35
4,000	0.67	0.88	0.96	1.21	1.48	1.58	1.76	2.07	2.46	2.61	2.82	3.22

Operational errors (TOOL4COOL® or LED flashes)

Error code or LED flashes	Error type
	Can be read out in the software TOOL4COOL®
6	Thermostat failure (If the NTC thermistor is short-circuit or has no connection, the electronic unit will enter manual mode).
5	Thermal cut-out of electronic unit (If the refrigeration system has been too heavily loaded, or if the ambient temperature is high, the electronic unit will run too hot).
4	Minimum motor speed error (If the refrigeration system is too heavily loaded, the motor cannot maintain minimum speed at approximately 1,850 rpm).
3	Motor start error (The rotor is blocked or the differential pressure in the refrigeration system is too high (>5 bar)).
2	Fan over-current cut-out (The fan loads the electronic unit with more than 0.65A _{peak}).
1	Battery protection cut-out (The voltage is outside the cut-out setting).

Wire Dimensions DC

Cross section [mm²]	Size		Max. length* 12V operation		Max. length* 24V operation	
	AWG	[Gauge]	[m]	[ft.]	[m]	[ft.]
2.5	12		2.5	8	5	16
4	12		4	13	8	26
6	10		6	20	12	39
10	8		10	33	20	66

*Length between battery and electronic unit

Accessories for BD1.4F-VSD-HD **Code number**

Bolt joint for one compressor	Ø:16 mm	118-1917
Bolt joint in quantities	Ø:16 mm	118-1918
Snap-on in quantities	Ø:16 mm	118-1919
Terminal cover for electronic unit		105N9120
Automobile fuse DIN 7258	12V: 15A 24V: 15A	Not deliverable from Secop
Main switch	min. 20A	

Test conditions

	EN 12900 CECOMAF	ASHRAE LBP
Condensing temperature	131°F	130°F
Ambient temperature	90°F	90°F
Suction gas temperature	90°F	90°F
Liquid temperature	no subcooling	90°F

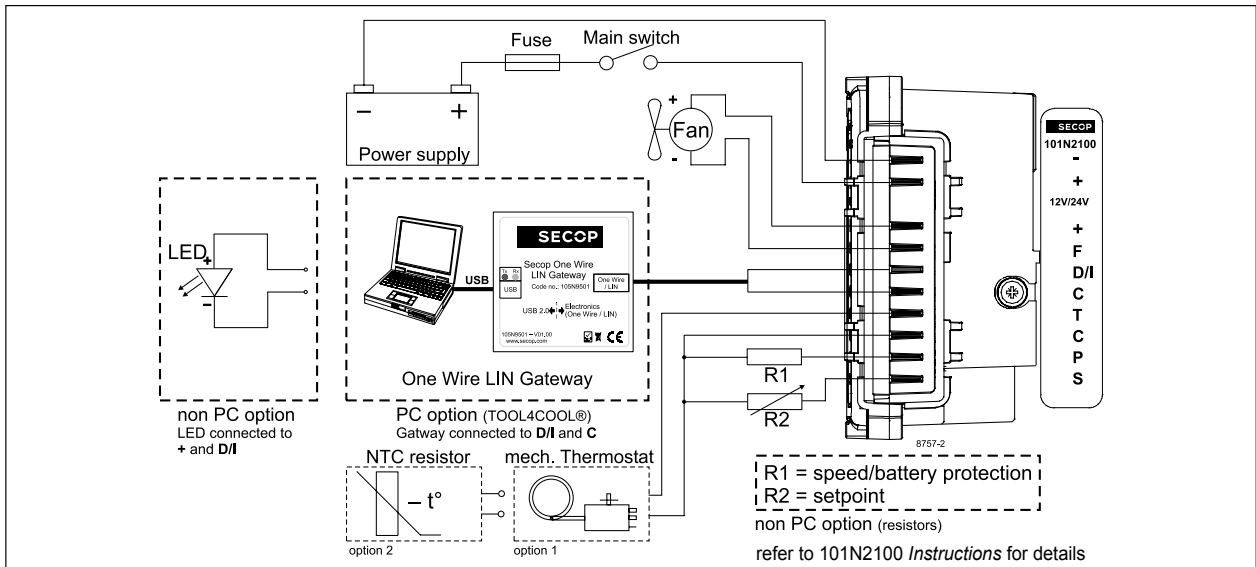



BD35F Direct Current Compressor R134a, 12-24V DC, 10-45V DC Solar & 100-240V AC 50/60Hz

General

Code number (without electronic units)	101Z0200
Electronic unit - Standard	101N0210, 30 pcs: 101N0211
Electronic unit 12-24V DC - EMI (with metal shielding)	101N0220, 30 pcs: 101N0221
Electronic unit 12-24V DC - AEO & EMI	101N0320, 30 pcs: 101N0321
Electronic unit 10-30V DC - Solar	101N0400, 30 pcs: 101N0401
Electronic unit 20-45V DC - Solar	101N0410, 30 pcs: 101N0411
Electronic unit 12-24V DC & 100-240V AC 50/60Hz	101N0500, 36 pcs: 101N0501
Electronic unit 12-24V DC - Automotive	101N0600, 30 pcs: 101N0601
Electronic unit 12-24V DC - Automotive	101N0630, 30 pcs: 101N0631
Approved compressor - electronic unit combinations	refer to <i>Instructions</i> for 101N0xxx
Additional approvals	e4, C-Tick
Compressors on pallet	150

Application

Application	LBP/MBP/HBP
Evaporating temperature °C	-30 to 0 (10)
Voltage range DC VDC	9.6 - 17 / 21.3 - 31.5
Voltage range AC V/Hz	100 - 240 / 50 - 60
Voltage range for solar applications VDC	10 - 30 / 20 - 45
Max. condensing temperature continuous (short) °C	60 (70)
Max. winding temperature continuous (short) °C	125 (135)

Cooling requirements

Application	LBP	MBP	HBP
32°C	S	S	S
38°C	S	S	S
43°C	S	S	S

Remarks on application: Fan cooling F₁ depending on application and speed.

Motor

Motor type	variable speed
Resistance, all 3 windings (25°C) Ω	2.2

Design

Displacement cm ³	2.00
Oil quantity (type) cm ³	150 (polyolester)
Maximum refrigerant charge g	300
Free gas volume in compressor cm ³	870
Weight - Compressor/Electronic unit kg	4.3 / 0.27 (Standard)

Standard battery protection settings (refer to 101N0xxx *Instructions* for optional settings)

Voltage	12V	24V
Cut out VDC	10.4	22.8
Cut in VDC	11.7	24.2

Dimensions

Height mm	A	137
	B	135
	B1	128
	B2	73
Suction connector location/I.D. mm angle	C	6.2 40°
	material comment	Cu-plated steel Al cap
Process connector location/I.D. mm angle	D	6.2 45°
	material comment	Cu-plated steel Al cap
Discharge connector location/I.D. mm angle	E	5.0 21°
	material comment	Cu-plated steel Al cap
Connector tolerance I.D. mm		±0.09, on 5.0 +0.12/+0.20

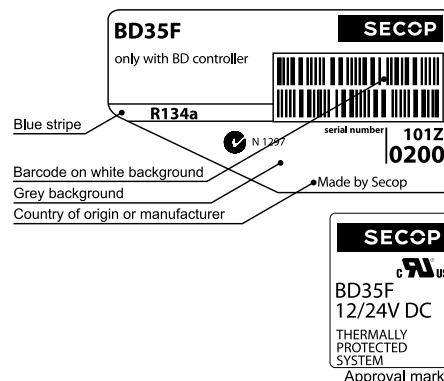

- S = Static cooling normally sufficient
- O = Oil cooling
- F₁ = Fan cooling 1.5 m/s (compressor compartment temperature equal to ambient temperature)
- F₂ = Fan cooling 3.0 m/s necessary
- SG = Suction gas cooling normally sufficient
- = not applicable in this area

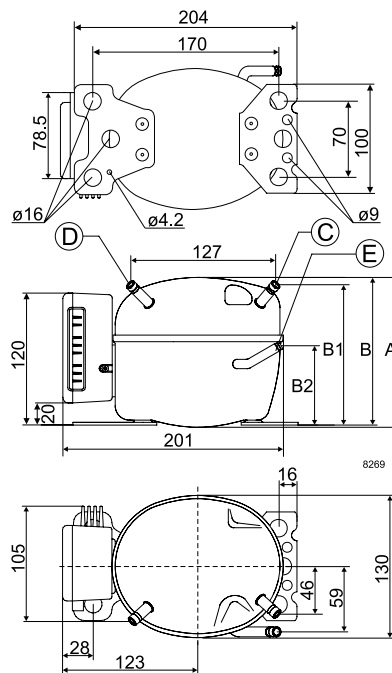



Capacity (EN 12900 Household/CECOMAF) 12V DC, static cooling watt

rpm \ °C	-30	-25	-23.3	-20	-15	-10	-5	0	5	7.2	10	15
2,000	15.8	23.9	26.9	33.1	43.8	56.6	71.7	89.9	111	122	136	
2,500	20.2	29.9	33.5	41.2	54.6	70.7	89.7	112	139	152		
3,000	22.5	32.4	36.5	45.4	61.8	81.7	105	133				
3,500	26.2	35.9	40.4	50.5	69.8	93.6	122					

Capacity (ASHRAE LBP) 12V DC, static cooling watt

rpm \ °C	-30	-25	-23.3	-20	-15	-10	-5	0	5	7.2	10	15
2,000	19.5	29.4	33.1	40.7	54.0	69.8	88.6	111	137	151	169	
2,500	24.9	36.8	41.3	50.7	67.3	87.1	111	139	172	189		
3,000	27.7	39.9	44.9	55.9	76.1	101	130	164				
3,500	32.2	44.2	49.7	62.2	86.0	115	150					

Power consumption 12V DC, static cooling watt

rpm \ °C	-30	-25	-23.3	-20	-15	-10	-5	0	5	7.2	10	15
2,000	17.6	23.4	25.3	28.7	33.6	38.3	43.0	48.0	53.4	56.0	59.5	
2,500	23.3	30.9	33.3	37.8	44.1	50.2	56.2	62.3	68.7	71.7		
3,000	29.9	36.0	38.3	43.0	50.7	58.7	66.8	74.8				
3,500	36.0	42.8	45.4	50.8	59.5	68.9	78.5					

Current consumption (for 24V applications the following must be halved) A

rpm \ °C	-30	-25	-23.3	-20	-15	-10	-5	0	5	7.2	10	15
2,000	1.5	2.0	2.1	2.4	2.8	3.2	3.6	4.0	4.5	4.67	5.0	
2,500	1.9	2.6	2.8	3.2	3.7	4.2	4.7	5.2	5.8	5.98		
3,000	2.5	3.0	3.2	3.6	4.2	4.9	5.6	6.2				
3,500	3.0	3.6	3.8	4.3	5.0	5.7	6.5					

COP (EN 12900 Household/CECOMAF) 12V DC, static cooling W/W

rpm \ °C	-30	-25	-23.3	-20	-15	-10	-5	0	5	7.2	10	15
2,000	0.90	1.02	1.06	1.15	1.31	1.48	1.67	1.87	2.08	2.17	2.29	
2,500	0.87	0.97	1.01	1.09	1.24	1.41	1.60	1.80	2.02	2.12		
3,000	0.75	0.90	0.95	1.06	1.22	1.39	1.58	1.78				
3,500	0.73	0.84	0.89	1.00	1.17	1.36	1.55					

COP (ASHRAE LBP) 12V DC, static cooling W/W

rpm \ °C	-30	-25	-23.3	-20	-15	-10	-5	0	5	7.2	10	15
2,000	1.10	1.25	1.31	1.42	1.61	1.82	2.06	2.31	2.57	2.70	2.84	
2,500	1.07	1.19	1.24	1.34	1.53	1.74	1.97	2.23	2.50	2.63		
3,000	0.93	1.11	1.17	1.30	1.50	1.72	1.95	2.20				
3,500	0.89	1.03	1.09	1.23	1.44	1.68	1.91					

Test conditions	EN 12900/CECOMAF	ASHRAE LBP
Condensing temperature	55°C	54.4°C
Ambient temperature	32°C	32°C
Suction gas temperature	32°C	32°C
Liquid temperature	no subcooling	32°C

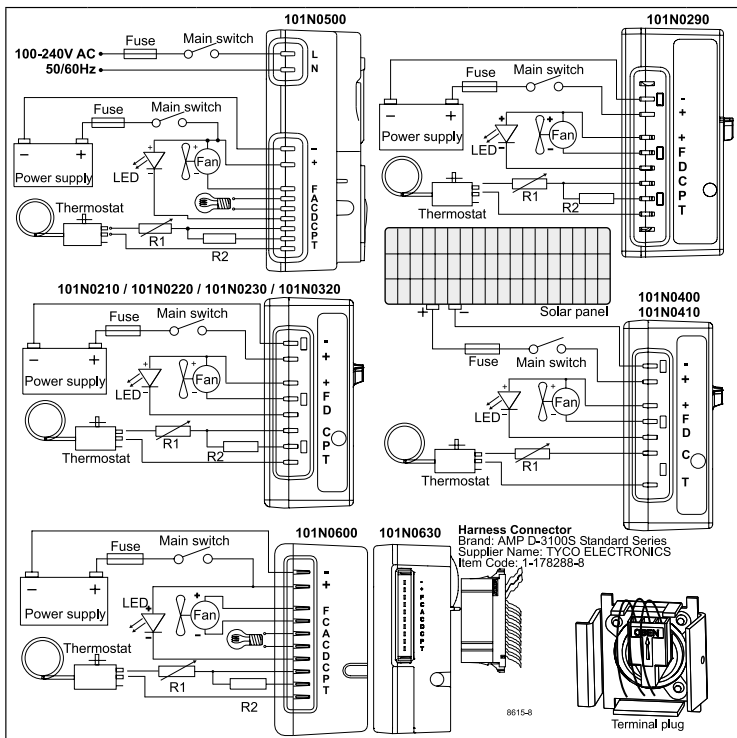

Operational errors shown by LED (optional)

Error code	Error type
5	Thermal cut-out of electronic unit (If the refrigeration system has been too heavily loaded, or if the ambient temperature is high, the electronic unit will run too hot).
4	Minimum motor speed error (If the refrigeration system is too heavily loaded, the motor cannot maintain minimum speed at approximately 1,850 rpm).
3	Motor start error (The rotor is blocked or the differential pres-sure in the refrigeration system is too high (>5 bar)).
2	Fan over-current cut-out (The fan loads the electronic unit with more than 1A _{peak}).
1	Battery protection cut-out (The voltage is outside the cut-out setting).

Compressor speed

Electronit unit	Resistor (R1) [Ω] calculated values	Motor speed [rpm]	Control circuit current [mA]
101N0210	0	2,000	5
101N0220	277	2,500	4
101N0500	692	3,000	3
101N0600	1523	3,500	2
101N0320	0	AEO	6
101N0400	173	2,000	5
101N0410	450	2,500	4
with AEO	865	3,000	3
	1696	3,500	2

In AEO (Adaptive Energy Optimizing) speed mode the BD compressor will always adapt its speed to the actual cooling demand.

Wire Dimensions DC

Size	Cross section [mm²]	AWG [Gauge]	Max. length* 12V operation		Max. length* 24V operation	
			[m]	[ft.]	[m]	[ft.]
2.5	12	12	2.5	8	5	16
4	12	4	4	13	8	26
6	10	6	6	20	12	39
10	8	10	10	33	20	66

*Length between battery and electronic unit

Wire Dimensions AC
Cross section min. 0.75 mm² or AWG 18

Accessories for BD35F

Accessories for BD35F	Code number
Bolt joint for one comp. Ø:16 mm	118-1917
Bolt joint in quantities Ø:16 mm	118-1918
Snap-on in quantities Ø:16 mm	118-1919
Remote kit (without cable)	105N9210

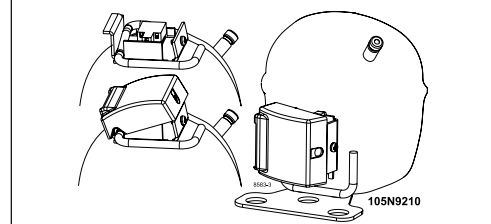

AC line cord UL approved	105N9520
AC line cord VDE approved	105N9530
DC usage:	Automobile fuse 12V: 15A DIN 7258 24V: 7.5 A Main switch min. 20A
AC usage:	Fuse, 100-240V min. 4A Main switch min. 6A

Not deliverable from Secop



BD35F Direct Current Compressor R134a, 12-24V DC, 10-45V DC Solar & 100-240V AC 50/60Hz

General

Code number (without electronic units)	101Z0204
Electronic unit - Standard	101N0210, 30 pcs: 101N0211
Electronic unit 12-24V DC - EMI (with metal shielding)	101N0220, 30 pcs: 101N0221
Electronic unit 12-24V DC - AEO & EMI	101N0320, 30 pcs: 101N0321
Electronic unit 10-30V DC - Solar	101N0400, 30 pcs: 101N0401
Electronic unit 20-45V DC - Solar	101N0410, 30 pcs: 101N0411
Electronic unit 12-24V DC & 100-240V AC 50/60Hz	101N0500, 36 pcs: 101N0501
Electronic unit 12-24V DC - Automotive	101N0600, 30 pcs: 101N0601
Electronic unit 12-24V DC - Automotive	101N0630, 30 pcs: 101N0631
Approved compressor - electronic unit combinations	refer to <i>Instructions</i> for 101N0xxx
Additional approvals	e4, C-Tick
Compressors on pallet	150

Application

Application	LBP/MBP/HBP	
Evaporating temperature	°F	-20 to 50
Voltage range DC	VDC	9.6 - 17 / 21.3 - 31.5
Voltage range AC	V/Hz	100 - 240 / 50 - 60
Voltage range for solar applications	VDC	10 - 30 / 20 - 45
Max. condensing temperature continuous (short)	°F	140 (158)
Max. winding temperature continuous (short)	°F	257 (275)

Cooling requirements

Application	LBP	MBP	HBP
32°C	S	S	S
38°C	S	S	S
43°C	S	S	S

Remarks on application: Fan cooling F₁ depending on application and speed.

Motor

Motor type	variable speed
Resistance, all 3 windings (25°C)	Ω 2.2

Design

Displacement	cu.in.	0.12
Oil quantity (type)	fl.oz.	5.1 (polyolester)
Maximum refrigerant charge	oz.	10.5
Free gas volume in compressor	fl.oz.	29.6
Weight - Compressor/Electronic unit	lbs.	9.5 / 0.59 (Standard)

Standard battery protection settings (refer to 101N0xxx *Instructions* for optional settings)

Voltage	12V	24V
Cut out	VDC 10.4	22.8
Cut in	VDC 11.7	24.2

Dimensions

Height	inch	A	5.39
		B	5.32
		B1	5.04
		B2	2.87
Suction connector	location/I.D. inch angle	C	0.252-0.259 40°
	material comment		Cu-plated steel Al cap
Process connector	location/I.D. inch angle	D	0.252-0.259 45°
	material comment		Cu-plated steel Al cap
Discharge connector	location/I.D. inch angle	E	0.202-0.205 21°
	material comment		Cu-plated steel Al cap

Remarks: **inch connectors**

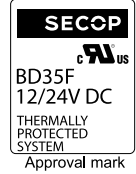
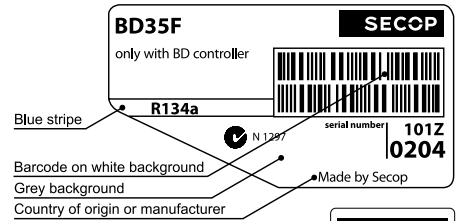

- S = Static cooling normally sufficient
- O = Oil cooling
- F₁ = Fan cooling 1.5 m/s
(compressor compartment temperature equal to ambient temperature)
- F₂ = Fan cooling 3.0 m/s necessary
- SG = Suction gas cooling normally sufficient
- = not applicable in this area

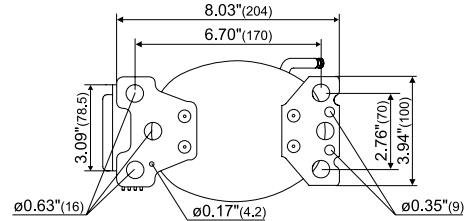
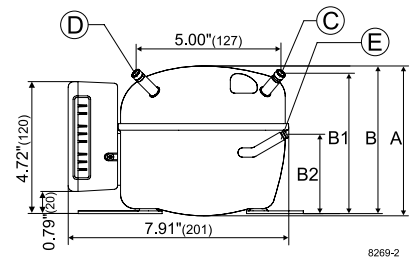
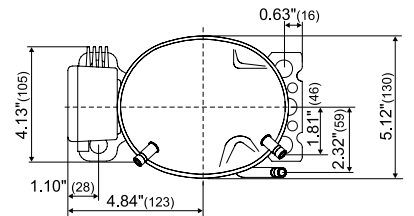



Capacity (ASHRAE LBP) 12V DC, static cooling **BTU/h**

rpm \ °F	-20	-13	-10	0	10	14	20	30	40	41	45	50
2,000	74	101	113	159	214	238	280	361	458	471	514	575
2,500	95	127	142	199	268	298	351	452	574	586	643	
3,000	104	138	155	222	307	344	411	535	681			
3,500	119	153	171	248	349	396	473	620				

Capacity (EN 12900 Household/CECOMAF) 12V DC, static cooling **watt**

rpm \ °F	-20	-13	-10	0	10	14	20	30	40	41	45	50
2,000	17.5	23.9	26.8	37.6	50.6	56.6	66.4	85.5	109	111	122	136
2,500	22.2	29.9	33.4	46.9	63.2	70.7	83.0	107	136	139	152	
3,000	24.5	32.4	36.4	52.3	72.4	81.7	97.0	126	161			
3,500	27.9	35.9	40.3	58.5	82.5	93.6	112	147				

Power consumption 12V DC, static cooling **watt**

rpm \ °F	-20	-13	-10	0	10	14	20	30	40	41	45	50
2,000	19.1	23.5	25.3	30.8	36.1	38.3	41.3	46.6	52.5	53.4	55.7	59.1
2,500	25.2	31.0	33.3	40.7	47.4	50.2	54.0	60.7	67.7	68.7	71.5	
3,000	31.0	35.8	38.0	45.9	54.5	58.4	63.4	72.2	80.6			
3,500	37.5	42.9	45.4	54.5	64.4	68.9	74.9	85.7				

Current consumption (for 24V applications the following must be halved) **A**

rpm \ °F	-20	-13	-10	0	10	14	20	30	40	41	45	50
2,000	1.59	1.96	2.10	2.57	3.01	3.19	3.44	3.89	4.37	4.45	4.64	4.93
2,500	2.10	2.58	2.77	3.38	3.95	4.18	4.49	5.05	5.63	5.73	5.95	
3,000	2.61	3.01	3.19	3.86	4.58	4.89	5.32	6.06	6.76			
3,500	3.14	3.58	3.79	4.55	5.38	5.74	6.25	7.15				

EER (ASHRAE LBP) 12V DC, static cooling **BTU/Wh**

rpm \ °F	-20	-13	-10	0	10	14	20	30	40	41	45	50
2,000	3.88	4.30	4.48	5.16	5.93	6.24	6.80	7.74	8.73	8.82	9.23	9.73
2,500	3.75	4.09	4.26	4.89	5.64	5.93	6.50	7.46	8.47	8.53	9.00	
3,000	3.36	3.86	4.08	4.83	5.63	5.90	6.48	7.41	8.44			
3,500	3.16	3.56	3.77	4.56	5.42	5.73	6.31	7.23				

COP (EN 12900 Household/CECOMAF) 12V DC, static cooling **W/W**

rpm \ °F	-20	-13	-10	0	10	14	20	30	40	41	45	50
2,000	0.92	1.02	1.06	1.22	1.40	1.48	1.60	1.82	2.06	2.08	2.17	2.29
2,500	0.89	0.97	1.01	1.15	1.33	1.41	1.53	1.76	2.00	2.02	2.12	
3,000	0.79	0.90	0.96	1.13	1.32	1.40	1.52	1.74	1.98			
3,500	0.75	0.84	0.89	1.07	1.28	1.36	1.49	1.70				

Test conditions	EN 12900/CECOMAF	ASHRAE LBP
Condensing temperature	131°F	130°F
Ambient temperature	90°F	90°F
Suction gas temperature	90°F	90°F
Liquid temperature	no subcooling	90°F

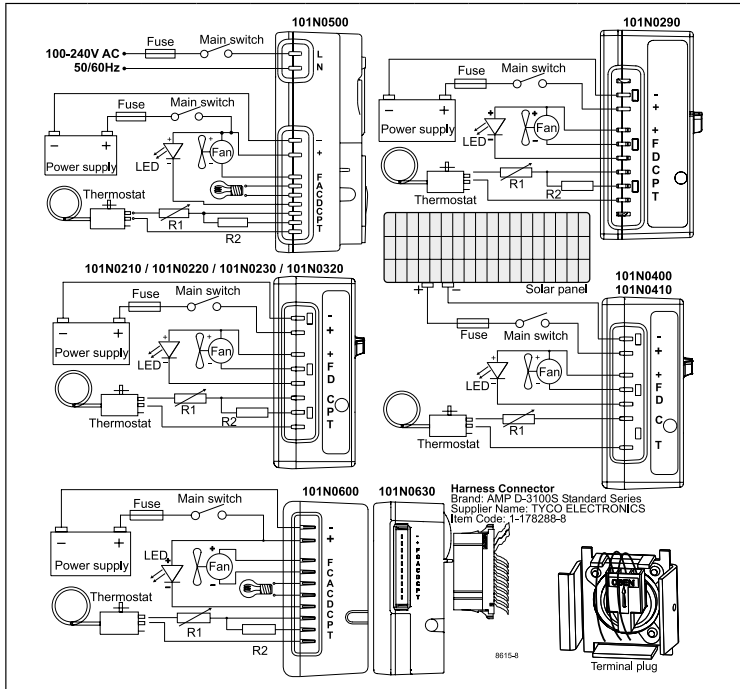

Operational errors shown by LED (optional)

Error code	Error type
5	Thermal cut-out of electronic unit (If the refrigeration system has been too heavily loaded, or if the ambient temperature is high, the electronic unit will run too hot).
4	Minimum motor speed error (If the refrigeration system is too heavily loaded, the motor cannot maintain minimum speed at approximately 1,850 rpm).
3	Motor start error (The rotor is blocked or the differential pressure in the refrigeration system is too high (>5 bar)).
2	Fan over-current cut-out (The fan loads the electronic unit with more than 1A _{peak}).
1	Battery protection cut-out (The voltage is outside the cut-out setting).

Compressor speed

Electronit unit	Resistor (R1) [Ω] calculated values	Motor speed [rpm]	Control circuit current [mA]
101N0210	0	2,000	5
101N0220	277	2,500	4
101N0500	692	3,000	3
101N0600	1523	3,500	2
101N0320	0	AEO	6
101N0400	173	2,000	5
101N0410	450	2,500	4
with AEO	865	3,000	3
	1696	3,500	2

In AEO (Adaptive Energy Optimizing) speed mode the BD compressor will always adapt its speed to the actual cooling demand.

Wire Dimensions DC

Cross section [mm ²]	Size AWG [Gauge]	Max. length* 12V operation		Max. length* 24V operation	
		[m]	[ft.]	[m]	[ft.]
2.5	12	2.5	8	5	16
4	12	4	13	8	26
6	10	6	20	12	39
10	8	10	33	20	66

*Length between battery and electronic unit

Wire Dimensions AC
Cross section min. 0.75 mm² or AWG 18

Accessories for BD35F

Accessories for BD35F	Code number
Bolt joint for one comp. Ø: 5/8 in.	118-1917
Bolt joint in quantities Ø: 5/8 in.	118-1918
Snap-on in quantities Ø: 5/8 in.	118-1919
Remote kit (without cable)	105N9210

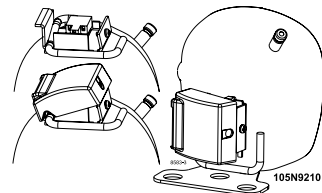

AC line cord UL approved	105N9520
AC line cord VDE approved	105N9530
DC usage:	Automobile fuse 12V: 15A DIN 7258 24V: 7.5 A Main switch min. 20A
AC usage:	Fuse, 100-240V min. 4A Main switch min. 6A

Not deliverable from Secop



BD35F-HD Heavy Duty Direct Current Compressor R134a, 12-24V DC

General

Code number (without electronic units)	101Z0206
Electronic unit - Standard	101N0210, 30 pcs: 101N0211
Approval for compressor - electronic unit combination	UL
Additional approvals	e4, C-Tick
Compressors on pallet	150

Application

Application	LBP/MBP/HBP
Evaporating temperature °C	-30 to 0 (10)
Voltage range VDC	9.6 - 17 / 21.3 - 31.5
Max. condensing temperature continuous (short) °C	60 (70)
Max. winding temperature continuous (short) °C	125 (135)

Cooling requirements

Application	LBP	MBP	HBP
32°C	S	S	S
38°C	S	S	S
43°C	S	S	S

Remarks on application:
HD (Heavy Duty) version of the BD35F which can handle extreme vibrations.
 Fan cooling F₁ depending on application and speed.
 For more info please contact: mobile@secop.com.

Motor

Motor type	variable speed
Resistance, all 3 windings (25°C)	Ω 2.2

Design

Displacement	cm ³	2.00
Oil quantity (type)	cm ³	150 (polyolester)
Maximum refrigerant charge	g	300
Free gas volume in compressor	cm ³	870
Weight - Compressor/Electronic unit	kg	4.3/0.27

Standard battery protection settings (refer to 101N0xxx Instructions for optional settings)

Voltage	12V	24V
Cut out	VDC 10.4	22.8
Cut in	VDC 11.7	24.2

Dimensions

Height	mm	A	137
		B	135
		B1	128
		B2	73
Suction connector	location/I.D. mm angle	C	6.2 40°
	material comment		Cu-plated steel Al cap
Process connector	location/I.D. mm angle	D	6.2 45°
	material comment		Cu-plated steel Al cap
Discharge connector	location/I.D. mm angle	E	5.0 21°
	material comment		Cu-plated steel Al cap
Connector tolerance	I.D. mm		±0.09, on 5.0 +0.12/+0.20
Remarks:			

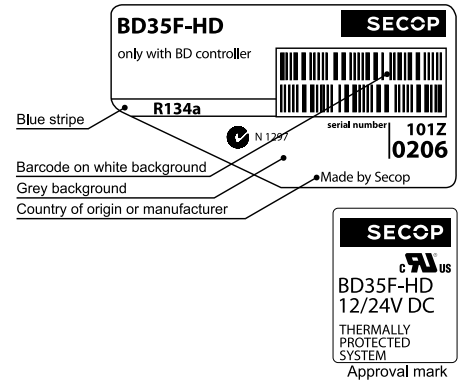

- S = Static cooling normally sufficient
- O = Oil cooling
- F₁ = Fan cooling 1.5 m/s (compressor compartment temperature equal to ambient temperature)
- F₂ = Fan cooling 3.0 m/s necessary
- SG = Suction gas cooling normally sufficient
- = not applicable in this area

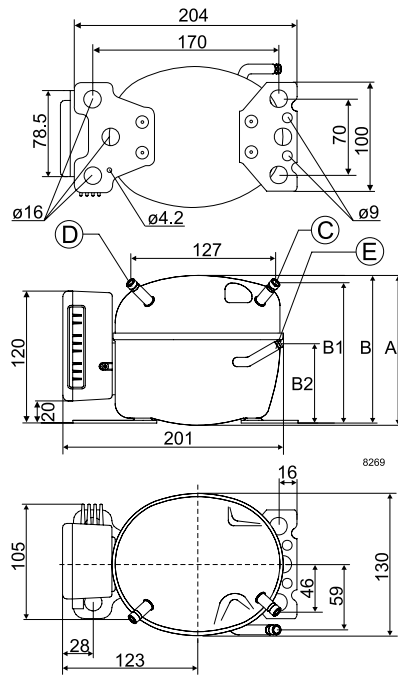



Capacity (EN 12900 Household/CECOMAF) 12V DC, static cooling **watt**

rpm \ °C	-30	-25	-23.3	-20	-15	-10	-5	0	5	7.2	10	15
2,000	15.8	23.9	26.9	33.1	43.8	56.6	71.7	89.9	111	122	136	
2,500	20.2	29.9	33.5	41.2	54.6	70.7	89.7	112	139	152		
3,000	22.5	32.4	36.5	45.4	61.8	81.7	105	133				
3,500	26.2	35.9	40.4	50.5	69.8	93.6	122					

Capacity (ASHRAE LBP) 12V DC, static cooling **watt**

rpm \ °C	-30	-25	-23.3	-20	-15	-10	-5	0	5	7.2	10	15
2,000	19.5	29.4	33.1	40.7	54.0	69.8	88.6	111	137	151	169	
2,500	24.9	36.8	41.3	50.7	67.3	87.1	111	139	172	189		
3,000	27.7	39.9	44.9	55.9	76.1	101	130	164				
3,500	32.2	44.2	49.7	62.2	86.0	115	150					

Power consumption 12V DC, static cooling **watt**

rpm \ °C	-30	-25	-23.3	-20	-15	-10	-5	0	5	7.2	10	15
2,000	17.6	23.4	25.3	28.7	33.6	38.3	43.0	48.0	53.4	56.0	59.5	
2,500	23.3	30.9	33.3	37.8	44.1	50.2	56.2	62.3	68.7	71.7		
3,000	29.9	36.0	38.3	43.0	50.7	58.7	66.8	74.8				
3,500	36.0	42.8	45.4	50.8	59.5	68.9	78.5					

Current consumption (for 24V applications the following must be halved) **A**

rpm \ °C	-30	-25	-23.3	-20	-15	-10	-5	0	5	7.2	10	15
2,000	1.5	2.0	2.1	2.4	2.8	3.2	3.6	4.0	4.5	4.67	5.0	
2,500	1.9	2.6	2.8	3.2	3.7	4.2	4.7	5.2	5.8	5.98		
3,000	2.5	3.0	3.2	3.6	4.2	4.9	5.6	6.2				
3,500	3.0	3.6	3.8	4.3	5.0	5.7	6.5					

COP (EN 12900 Household/CECOMAF) 12V DC, static cooling **W/W**

rpm \ °C	-30	-25	-23.3	-20	-15	-10	-5	0	5	7.2	10	15
2,000	0.90	1.02	1.06	1.15	1.31	1.48	1.67	1.87	2.08	2.17	2.29	
2,500	0.87	0.97	1.01	1.09	1.24	1.41	1.60	1.80	2.02	2.12		
3,000	0.75	0.90	0.95	1.06	1.22	1.39	1.58	1.78				
3,500	0.73	0.84	0.89	1.00	1.17	1.36	1.55					

COP (ASHRAE LBP) 12V DC, static cooling **W/W**

rpm \ °C	-30	-25	-23.3	-20	-15	-10	-5	0	5	7.2	10	15
2,000	1.10	1.25	1.31	1.42	1.61	1.82	2.06	2.31	2.57	2.70	2.84	
2,500	1.07	1.19	1.24	1.34	1.53	1.74	1.97	2.23	2.50	2.63		
3,000	0.93	1.11	1.17	1.30	1.50	1.72	1.95	2.20				
3,500	0.89	1.03	1.09	1.23	1.44	1.68	1.91					

Test conditions	EN 12900/CECOMAF	ASHRAE LBP
Condensing temperature	55°C	54.4°C
Ambient temperature	32°C	32°C
Suction gas temperature	32°C	32°C
Liquid temperature	no subcooling	32°C

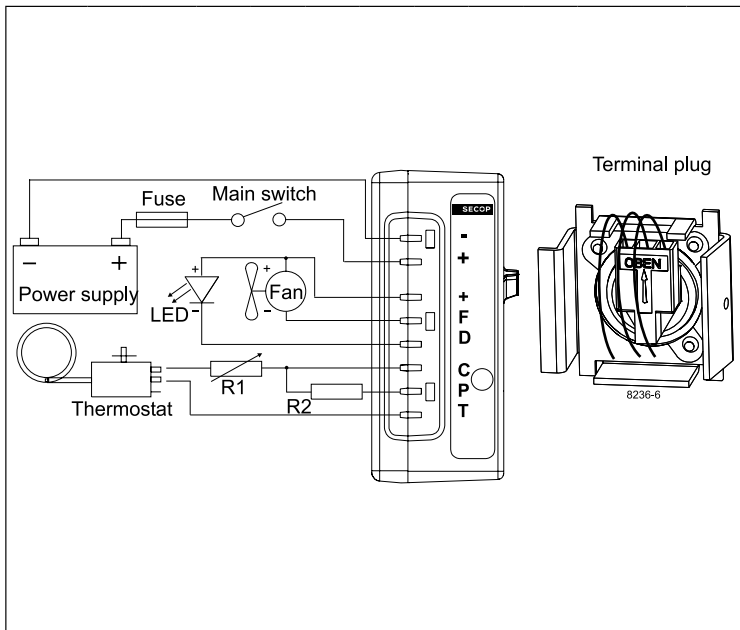

Operational errors shown by LED (optional)

Error code	Error type
5	Thermal cut-out of electronic unit (If the refrigeration system has been too heavily loaded, or if the ambient temperature is high, the electronic unit will run too hot).
4	Minimum motor speed error (If the refrigeration system is too heavily loaded, the motor cannot maintain minimum speed at approximately 1,850 rpm).
3	Motor start error (The rotor is blocked or the differential pressure in the refrigeration system is too high (>5 bar)).
2	Fan over-current cut-out (The fan loads the electronic unit with more than 1A _{peak}).
1	Battery protection cut-out (The voltage is outside the cut-out setting).

Compressor speed

Electronit unit	Resistor (R1) [Ω]	Motor speed [rpm]	Control circuit current [mA]
101N0210	0	2,000	5
	277	2,500	4
	692	3,000	3
	1523	3,500	2

Wire Dimensions DC

Cross section [mm²]	Size AWG [Gauge]	Max. length* 12V operation		Max. length* 24V operation	
		[m]	[ft.]	[m]	[ft.]
2.5	12	2.5	8	5	16
4	12	4	13	8	26
6	10	6	20	12	39
10	8	10	33	20	66

*Length between battery and electronic unit

Accessories for BD35F-HD	Code number
Bolt joint for one compressor Ø:16 mm	118-1917
Bolt joint in quantities Ø:16 mm	118-1918
Snap-on in quantities Ø:16 mm	118-1919
Remote kit (without cable)	105N9210

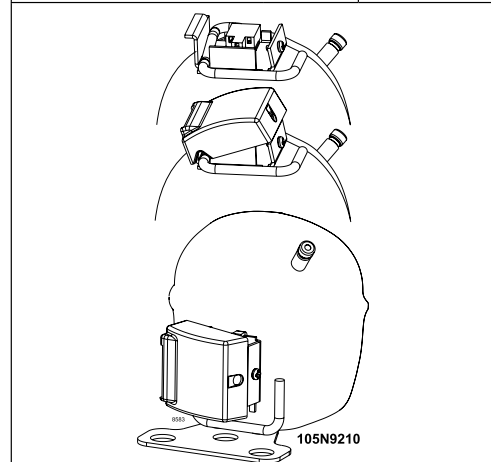

Standard automobile fuse DIN 7258	12V: 30A 24V: 15A	Not deliverable from Secop
Main switch	min. 30A	



BD35F-B Bus-optimized Direct Current Compressor R134a, 12-24V DC & 100-240V AC 50/60Hz

General

Code number (without electronic units)	101Z0205
Electronic unit - Standard	101N0210, 30 pcs: 101N0211
Electronic unit 12-24V DC - EMI (with metal shielding)	101N0220, 30 pcs: 101N0221
Electronic unit 12-24V DC - AEO & EMI	101N0320, 30 pcs: 101N0321
Electronic unit 12-24V DC & 100-240V AC 50/60Hz	101N0500, 36 pcs: 101N0501
Electronic unit 12-24V DC - Automotive	101N0600, 30 pcs: 101N0601
Electronic unit 12-24V DC - Automotive	101N0630, 30 pcs: 101N0631
Approved compressor - electronic unit combinations	refer to <i>Instructions</i> for 101N0xxx
Additional approvals	e4, C-Tick
Compressors on pallet	150

Application

Application	LBP/MBP/HBP	
Evaporating temperature	°C	-30 to 0 (10)
Voltage range DC	VDC	9.6 - 17 / 21.3 - 31.5
Voltage range AC	V/Hz	100 - 240 / 50 - 60
Max. condensing temperature continuous (short)	°C	60 (70)
Max. winding temperature continuous (short)	°C	125 (135)

Cooling requirements

Application	LBP	MBP	HBP
32°C	S	S	S
38°C	S	S	S
43°C	S	S	S

Remarks on application: Fan cooling F₁ depending on application and speed.

Special version of the BD35F optimized for rough vehicle motions, especially in buses.

For more info please contact: mobile@secop.com.

Motor

Motor type	variable speed
Resistance, all 3 windings (25°C)	Ω 2.2

Design

Displacement	cm ³	2.00
Oil quantity (type)	cm ³	150 (polyolester)
Maximum refrigerant charge	g	300
Free gas volume in compressor	cm ³	870
Weight - Compressor/Electronic unit	kg	4.3 / 0.27 (Standard)

Standard battery protection settings (refer to 101N0xxx *Instructions* for optional settings)

Voltage	12V	24V
Cut out	VDC 10.4	22.8
Cut in	VDC 11.7	24.2

Dimensions

Height	mm	A	137
		B	135
		B1	128
		B2	73
Suction connector	location/I.D. mm angle	C	6.2 40°
	material comment		Cu-plated steel Al cap
Process connector	location/I.D. mm angle	D	6.2 45°
	material comment		Cu-plated steel Al cap
Discharge connector	location/I.D. mm angle	E	5.0 21°
	material comment		Cu-plated steel Al cap
Connector tolerance	I.D. mm		±0.09, on 5.0 +0.12/+0.20

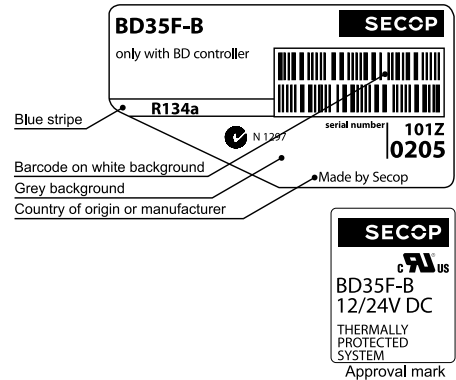

- S = Static cooling normally sufficient
- O = Oil cooling
- F₁ = Fan cooling 1.5 m/s (compressor compartment temperature equal to ambient temperature)
- F₂ = Fan cooling 3.0 m/s necessary
- SG = Suction gas cooling normally sufficient
- = not applicable in this area

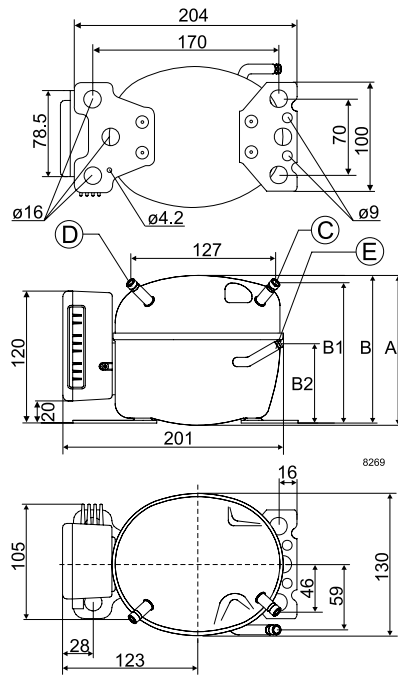



Capacity (EN 12900 Household/CECOMAF) 12V DC, static cooling **watt**

rpm \ °C	-30	-25	-23.3	-20	-15	-10	-5	0	5	7.2	10	15
2,000	15.8	23.9	26.9	33.1	43.8	56.6	71.7	89.9	111	122	136	
2,500	20.2	29.9	33.5	41.2	54.6	70.7	89.7	112	139	152		
3,000	22.5	32.4	36.5	45.4	61.8	81.7	105	133				
3,500	26.2	35.9	40.4	50.5	69.8	93.6	122					

Capacity (ASHRAE LBP) 12V DC, static cooling **watt**

rpm \ °C	-30	-25	-23.3	-20	-15	-10	-5	0	5	7.2	10	15
2,000	19.5	29.4	33.1	40.7	54.0	69.8	88.6	111	137	151	169	
2,500	24.9	36.8	41.3	50.7	67.3	87.1	111	139	172	189		
3,000	27.7	39.9	44.9	55.9	76.1	101	130	164				
3,500	32.2	44.2	49.7	62.2	86.0	115	150					

Power consumption 12V DC, static cooling **watt**

rpm \ °C	-30	-25	-23.3	-20	-15	-10	-5	0	5	7.2	10	15
2,000	17.6	23.4	25.3	28.7	33.6	38.3	43.0	48.0	53.4	56.0	59.5	
2,500	23.3	30.9	33.3	37.8	44.1	50.2	56.2	62.3	68.7	71.7		
3,000	29.9	36.0	38.3	43.0	50.7	58.7	66.8	74.8				
3,500	36.0	42.8	45.4	50.8	59.5	68.9	78.5					

Current consumption (for 24V applications the following must be halved) **A**

rpm \ °C	-30	-25	-23.3	-20	-15	-10	-5	0	5	7.2	10	15
2,000	1.5	2.0	2.1	2.4	2.8	3.2	3.6	4.0	4.5	4.67	5.0	
2,500	1.9	2.6	2.8	3.2	3.7	4.2	4.7	5.2	5.8	5.98		
3,000	2.5	3.0	3.2	3.6	4.2	4.9	5.6	6.2				
3,500	3.0	3.6	3.8	4.3	5.0	5.7	6.5					

COP (EN 12900 Household/CECOMAF) 12V DC, static cooling **W/W**

rpm \ °C	-30	-25	-23.3	-20	-15	-10	-5	0	5	7.2	10	15
2,000	0.90	1.02	1.06	1.15	1.31	1.48	1.67	1.87	2.08	2.17	2.29	
2,500	0.87	0.97	1.01	1.09	1.24	1.41	1.60	1.80	2.02	2.12		
3,000	0.75	0.90	0.95	1.06	1.22	1.39	1.58	1.78				
3,500	0.73	0.84	0.89	1.00	1.17	1.36	1.55					

COP (ASHRAE LBP) 12V DC, static cooling **W/W**

rpm \ °C	-30	-25	-23.3	-20	-15	-10	-5	0	5	7.2	10	15
2,000	1.10	1.25	1.31	1.42	1.61	1.82	2.06	2.31	2.57	2.70	2.84	
2,500	1.07	1.19	1.24	1.34	1.53	1.74	1.97	2.23	2.50	2.63		
3,000	0.93	1.11	1.17	1.30	1.50	1.72	1.95	2.20				
3,500	0.89	1.03	1.09	1.23	1.44	1.68	1.91					

Test conditions	EN 12900/CECOMAF	ASHRAE LBP
Condensing temperature	55°C	54.4°C
Ambient temperature	32°C	32°C
Suction gas temperature	32°C	32°C
Liquid temperature	no subcooling	32°C

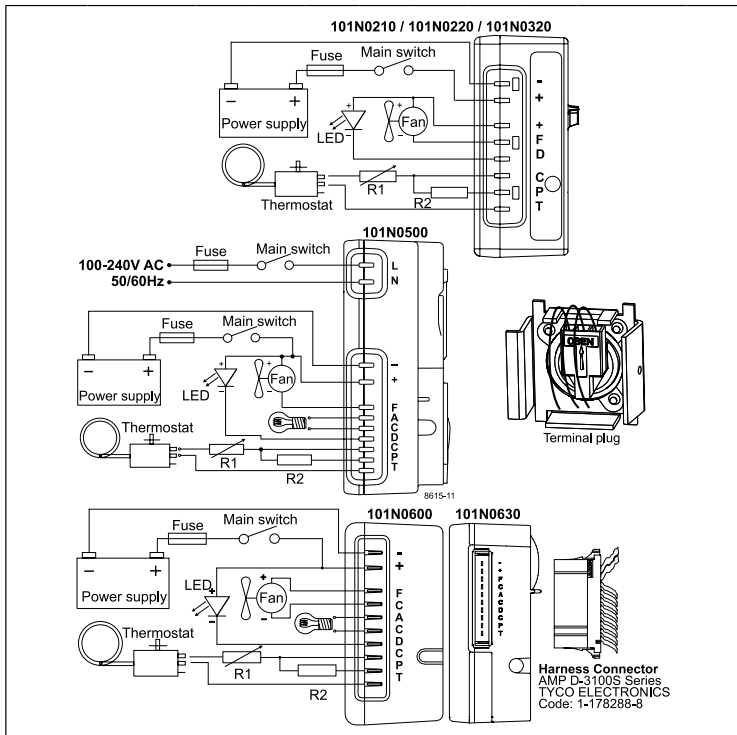

Operational errors shown by LED (optional)

Error code	Error type
5	Thermal cut-out of electronic unit (If the refrigeration system has been too heavily loaded, or if the ambient temperature is high, the electronic unit will run too hot).
4	Minimum motor speed error (If the refrigeration system is too heavily loaded, the motor cannot maintain minimum speed at approximately 1,850 rpm).
3	Motor start error (The rotor is blocked or the differential pres-sure in the refrigeration system is too high (>5 bar)).
2	Fan over-current cut-out (The fan loads the electronic unit with more than 1A _{peak}).
1	Battery protection cut-out (The voltage is outside the cut-out setting).

Compressor speed

Electronit unit Code number	Resistor (R1) [Ω] calculated values	Motor speed [rpm]	Control circuit current [mA]
101N0210	0	2,000	5
101N0220	277	2,500	4
101N0500	692	3,000	3
101N0600	1523	3,500	2
101N0320 with AEO	0	AEO	6
	173	2,000	5
	450	2,500	4
	865	3,000	3
	1696	3,500	2

In AEO (Adaptive Energy Optimizing) speed mode the BD compressor will always adapt its speed to the actual cooling demand.

Wire Dimensions DC

Size Cross section	AWG	Max. length* 12V operation		Max. length* 24V operation	
		[m]	[ft.]	[m]	[ft.]
2.5 [mm ²]	12	2.5	8	5	16
4	12	4	13	8	26
6	10	6	20	12	39
10	8	10	33	20	66

*Length between battery and electronic unit

Wire Dimensions AC
Cross section min. 0.75 mm² or AWG 18

Accessories for BD35F-B

	Code number
Bolt joint for one comp. Ø:16 mm	118-1917
Bolt joint in quantities Ø:16 mm	118-1918
Snap-on in quantities Ø:16 mm	118-1919
Remote kit (without cable)	105N9210

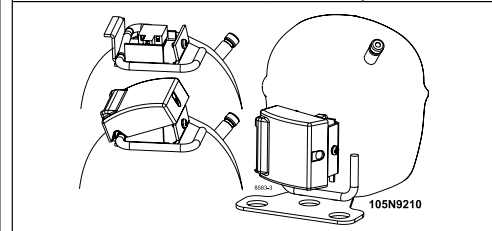

AC line cord UL approved	105N9520						
AC line cord VDE approved	105N9530						
DC usage:	<table border="1"> <tr> <td>Automobile fuse</td> <td>12V: 15A</td> </tr> <tr> <td>DIN 7258</td> <td>24V: 7.5 A</td> </tr> <tr> <td>Main switch</td> <td>min. 20A</td> </tr> </table>	Automobile fuse	12V: 15A	DIN 7258	24V: 7.5 A	Main switch	min. 20A
Automobile fuse	12V: 15A						
DIN 7258	24V: 7.5 A						
Main switch	min. 20A						
AC usage:	<table border="1"> <tr> <td>Fuse, 100-240V</td> <td>min. 4A</td> </tr> <tr> <td>Main switch</td> <td>min. 6A</td> </tr> </table>	Fuse, 100-240V	min. 4A	Main switch	min. 6A		
Fuse, 100-240V	min. 4A						
Main switch	min. 6A						

Not deliverable from Secop



BD50F Direct Current Compressor R134a, 12-24V DC & 100-240V AC 50/60Hz

General

Code number (without electronic units)	101Z1220
Electronic unit - Standard	101N0210, 30 pcs: 101N0211
Electronic unit 12-24V DC - EMI (with metal shielding)	101N0220, 30 pcs: 101N0221
Electronic unit 12-24V DC - High Start Performance	101N0230, 30 pcs: 101N0231
Electronic unit 12-24V DC - AEO & EMI	101N0320, 30 pcs: 101N0321
Electronic unit 12-24V DC - AEO & High Start	101N0330, 30 pcs: 101N0331
Electronic unit 12-24V DC & 100-240V AC 50/60Hz	101N0500, 36 pcs: 101N0501
Approved compressor - electronic unit combinations	refer to <i>Instructions</i> for 101N0xxx
Additional approvals	e4, C-Tick
Compressors on pallet	150

Application

Application	LBP/MBP/HBP		
Evaporating temperature °C	-30 to 0 (10)		
Voltage range DC VDC	9.6 - 17 / 21.3 - 31.5		
Voltage range AC V/Hz	100 - 240 / 50 - 60		
Max. condensing temperature continuous (short) °C	60 (70)		
Max. winding temperature continuous (short) °C	125 (135)		

Cooling requirements

Application	LBP	MBP	HBP
32°C	S	S	F ₁
38°C	S	S	F ₁
43°C	S	S	F ₁

Remarks on application: Fan cooling F₁ depending on application and speed.

Motor

Motor type	variable speed
Resistance, all 3 windings (25°C) Ω	1.8

Design

Displacement cm ³	2.50
Oil quantity (type) cm ³	150 (polyolester)
Maximum refrigerant charge g	300
Free gas volume in compressor cm ³	870
Weight - Compressor/Electronic unit kg	4.3 / 0.27 (Standard)

Standard battery protection settings (refer to 101N0xxx *Instructions* for optional settings)

	12V	24V
Voltage VDC	10.4	22.8
Cut out VDC	11.7	24.2
Cut in VDC		

Dimensions

Height mm	A	137
	B	135
	B1	128
	B2	73
Suction connector location/I.D. mm angle	C	6.2 40°
material comment	Cu-plated steel Al cap	
Process connector location/I.D. mm angle	D	6.2 45°
material comment	Cu-plated steel Al cap	
Discharge connector location/I.D. mm angle	E	5.0 21°
material comment	Cu-plated steel Al cap	
Connector tolerance I.D. mm	±0.09, on 5.0 +0.12/+0.20	
Remarks:		

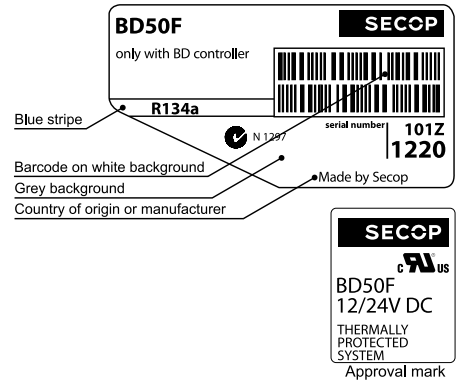

- S = Static cooling normally sufficient
- O = Oil cooling
- F₁ = Fan cooling 1.5 m/s (compressor compartment temperature equal to ambient temperature)
- F₂ = Fan cooling 3.0 m/s necessary
- SG = Suction gas cooling normally sufficient
- = not applicable in this area

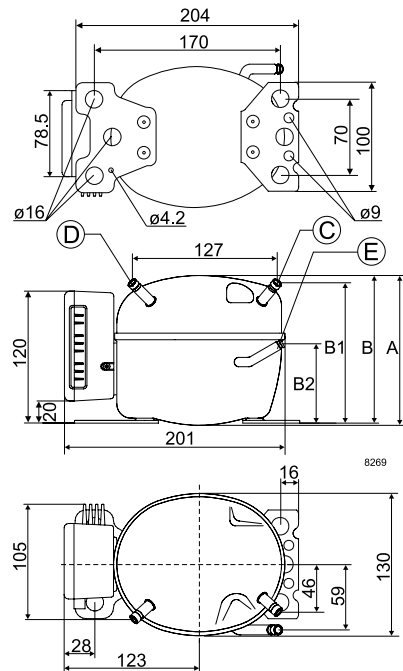

Capacity (EN 12900 Household/CECOMAF) 12V DC, static cooling watt												
rpm \ °C	-30	-25	-23.3	-20	-15	-10	-5	0	5	7.2	10	15
2,000	20.8	30.0	33.6	41.6	55.9	72.6	91.9	114	138*	150*	165*	
2,500	25.9	37.3	41.8	51.4	68.4	88.9	113	142*	175*	191*		
3,000	30.9	44.8	50.2	61.7	82.2	107	136*	169*				
3,500	36.7	52.2	58.3	71.4	94.9	123*	157*					

Capacity (ASHRAE LBP) 12V DC, static cooling watt												
rpm \ °C	-30	-25	-23.3	-20	-15	-10	-5	0	5	7.2	10	15
2,000	25.6	37.0	41.5	51.4	69.0	89.8	114	141	171*	186*	205*	
2,500	31.9	46.0	51.5	63.4	84.5	110	140	176*	217*	237*		
3,000	38.1	55.3	61.9	76.2	101	132	168*	210*				
3,500	45.2	64.4	71.9	88.2	117	152*	194*					

Power consumption 12V DC, static cooling watt												
rpm \ °C	-30	-25	-23.3	-20	-15	-10	-5	0	5	7.2	10	15
2,000	26.0	32.7	34.9	39.2	45.8	52.6	60.0	68.0	76.9*	81.2*	87.0*	
2,500	32.2	41.4	44.5	50.3	59.0	67.7	76.4	85.4*	94.9*	99.2*		
3,000	38.9	50.3	54.0	61.0	71.2	81.3	91.5*	102*				
3,500	47.0	59.0	63.0	70.7	82.6	95.0*	108*					

Power consumption is limited to 100W with electronic unit 101N0500.

Current consumption (for 24V applications the following must be halved) A												
rpm \ °C	-30	-25	-23.3	-20	-15	-10	-5	0	5	7.2	10	15
2,000	2.16	2.69	2.88	3.26	3.85	4.49	5.15	5.85	6.58*	6.91*	7.35*	
2,500	2.69	3.40	3.65	4.12	4.86	5.61	6.37	7.15*	7.94*	8.29*		
3,000	3.33	4.16	4.44	5.00	5.87	6.75	7.65*	8.57*				
3,500	4.02	4.89	5.20	5.83	6.83	7.90*	9.03*					

COP (EN 12900 Household/CECOMAF) W/W												
rpm \ °C	-30	-25	-23.3	-20	-15	-10	-5	0	5	7.2	10	15
2,000	0.80	0.92	0.96	1.06	1.22	1.38	1.53	1.67	1.79*	1.84*	1.90*	
2,500	0.80	0.90	0.94	1.02	1.16	1.31	1.48	1.66*	1.84*	1.92*		
3,000	0.79	0.89	0.93	1.01	1.15	1.31	1.48*	1.66*				
3,500	0.78	0.88	0.93	1.01	1.15	1.30*	1.45*					

COP (ASHRAE LBP) 12V DC, static cooling W/W												
rpm \ °C	-30	-25	-23.3	-20	-15	-10	-5	0	5	7.2	10	15
2,000	0.99	1.13	1.19	1.31	1.51	1.71	1.90	2.07	2.23*	2.29*	2.36*	
2,500	0.99	1.11	1.16	1.26	1.43	1.62	1.83	2.05*	2.29*	2.39*		
3,000	0.98	1.10	1.15	1.25	1.43	1.62	1.83*	2.05*				
3,500	0.96	1.09	1.14	1.25	1.42	1.60*	1.79*					

power consumption is limited to 100W with 101N0500 * fan cooling of electronic unit compulsory

Test conditions	EN 12900/CECOMAF	ASHRAE LBP
Condensing temperature	55°C	54.4°C
Ambient temperature	32°C	32°C
Suction gas temperature	32°C	32°C
Liquid temperature	no subcooling	32°C

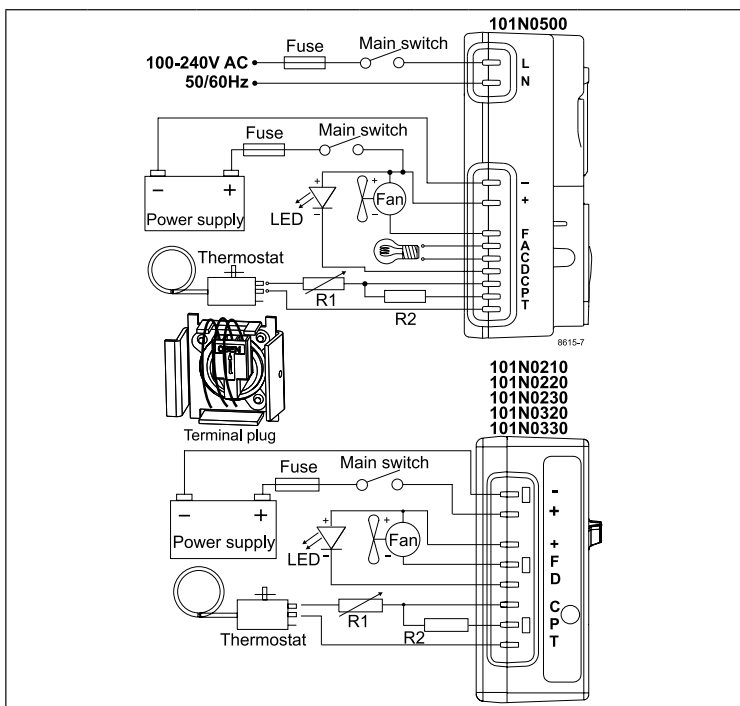

Error code	Error type
5	Thermal cut-out of electronic unit (If the refrigeration system has been too heavily loaded, or if the ambient temperature is high, the electronic unit will run too hot).
4	Minimum motor speed error (If the refrigeration system is too heavily loaded, the motor cannot maintain minimum speed at approximately 1,850 rpm).
3	Motor start error (The rotor is blocked or the differential pres-sure in the refrigeration system is too high (>5 bar)).
2	Fan over-current cut-out (The fan loads the electronic unit with more than 1A _{peak}).
1	Battery protection cut-out (The voltage is outside the cut-out setting).

Compressor speed	Resistor (R1) [Ω] calculated values	Motor speed [rpm]	Control circuit current [mA]
101N0210	0	2,000	5
101N0220	277	2,500	4
101N0230	692	3,000	3
101N0500	1523	3,500	2
101N0320 101N0330 with AEO	0	AEO	6
	173	2,000	5
	450	2,500	4
	865	3,000	3
	1696	3,500	2

In AEO (Adaptive Energy Optimizing) speed mode the BD compressor will always adapt its speed to the actual cooling demand.

Cross section [mm²]	Size		Max. length* 12V operation		Max. length* 24V operation	
	AWG	[Gauge]	[m]	[ft.]	[m]	[ft.]
2.5	12		2.5	8	5	16
4	12		4	13	8	26
6	10		6	20	12	39
10	8		10	33	20	66

*Length between battery an electronic unit

Wire Dimensions AC
Cross section min. 0.75 mm² or AWG 18

Accessories for BD50F	Code number
Bolt joint for one comp. Ø: 16 mm	118-1917
Bolt joint in quantities Ø: 16 mm	118-1918
Snap-on in quantities Ø: 16 mm	118-1919
Remote kit (without cable)	105N9210

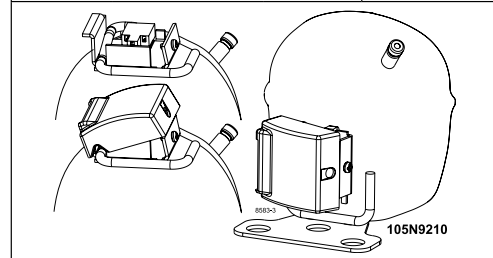

AC line cord UL approved	105N9520
AC line cord VDE approved	105N9530
DC usage:	Automobile fuse 12V: 15A DIN 7258 24V: 7.5 A
	Main switch min. 20A
AC usage:	Fuse, 100-240V min. 4A
	Main switch min. 6A



BD50F Direct Current Compressor R134a, 12-24V DC & 100-240V AC 50/60Hz

General

Code number (without electronic units)	101Z0203
Electronic unit - Standard	101N0210, 30 pcs: 101N0211
Electronic unit 12-24V DC - EMI (with metal shielding)	101N0220, 30 pcs: 101N0221
Electronic unit 12-24V DC - High Start Performance	101N0230, 30 pcs: 101N0231
Electronic unit 12-24V DC - AEO & EMI	101N0320, 30 pcs: 101N0321
Electronic unit 12-24V DC - AEO & High Start	101N0330, 30 pcs: 101N0331
Electronic unit 12-24V DC & 100-240V AC 50/60Hz	101N0500, 36 pcs: 101N0501
Approved compressor - electronic unit combinations	refer to <i>Instructions</i> for 101N0xxx
Additional approvals	e4, C-Tick
Compressors on pallet	150

Application

Application	LBP/MBP/HBP	
Evaporating temperature	°F	-20 to 50
Voltage range DC	VDC	9.6 - 17 / 21.3 - 31.5
Voltage range AC	V/Hz	100 - 240 / 50 - 60
Max. condensing temperature continuous (short)	°F	140 (158)
Max. winding temperature continuous (short)	°F	257 (275)

Cooling requirements

Application	LBP	MBP	HBP
32°C	S	S	F ₁
38°C	S	S	F ₁
43°C	S	S	F ₁

Remarks on application: Fan cooling F₁ depending on application and speed.

Motor

Motor type	variable speed
Resistance, all 3 windings (25°C)	Ω 1.8

Design

Displacement	cu.in.	0.15
Oil quantity (type)	fl.oz.	5.1 (polyolester)
Maximum refrigerant charge	oz.	10.5
Free gas volume in compressor	fl.oz.	29.6
Weight - Compressor/Electronic unit	lbs.	9.5 / 0.59 (Standard)

Standard battery protection settings (refer to 101N0xxx *Instructions* for optional settings)

Voltage	12V	24V
Cut out	VDC 10.4	22.8
Cut in	VDC 11.7	24.2

Dimensions

Height	inch	A	5.39
		B	5.32
		B1	5.04
		B2	2.87
Suction connector	location/I.D. inch angle	C	0.252-0.259 40°
	material comment		Cu-plated steel Al cap
Process connector	location/I.D. inch angle	D	0.252-0.259 45°
	material comment		Cu-plated steel Al cap
Discharge connector	location/I.D. inch angle	E	0.202-0.205 21°
	material comment		Cu-plated steel Al cap

Remarks: **inch connectors**

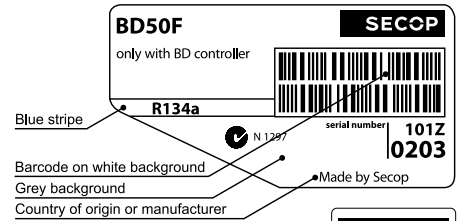

- S = Static cooling normally sufficient
- O = Oil cooling
- F₁ = Fan cooling 1.5 m/s (compressor compartment temperature equal to ambient temperature)
- F₂ = Fan cooling 3.0 m/s necessary
- SG = Suction gas cooling normally sufficient
- = not applicable in this area

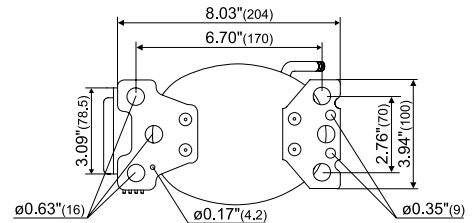
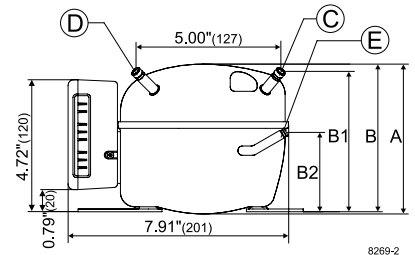
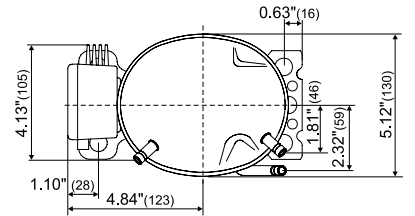



Capacity (ASHRAE LBP)		12V DC, static cooling										BTU/h
rpm \ °F	-20	-13	-10	0	10	14	20	30	40	41	45	50
2,000	95	126	142	201	273	308	359	458	571	583	632*	697*
2,500	119	157	176	247	335	375	442	570	723*	740	809*	
3,000	142	189	211	297	402	450	529	682*	863*			
3,500	167	220	245	343	464	518*	612*	790*				

Capacity (EN 12900 Household/CECOMAF)		12V DC, static cooling										watt
rpm \ °F	-20	-13	-10	0	10	14	20	30	40	41	45	50
2,000	22.6	30.0	33.6	47.7	64.9	72.6	85.2	109	135	138*	150*	165*
2,500	28.2	37.3	41.7	58.5	79.3	88.9	105	135	171*	175*	191*	
3,000	33.7	44.8	50.1	70.4	95.2	107	125	161*	204*			
3,500	39.8	52.2	58.2	81.3	110	123*	145*	187*				

Power consumption		12V DC, static cooling										watt
rpm \ °F	-20	-13	-10	0	10	14	20	30	40	41	45	50
2,000	27.4	32.5	34.6	41.7	49.0	52.6	56.8	65.4	75.1	76.9*	80.4*	86.2*
2,500	34.3	41.4	44.3	54.0	63.4	67.7	73.0	82.8	93.1*	94.9*	98.6*	
3,000	41.4	50.1	53.7	65.2	76.2	81.3	87.4	98.9*	111*			
3,500	49.6	58.8	62.6	75.5	88.7	95.0*	103*	119*				

Current consumption (for 24V applications the following must be halved)		A										
rpm \ °F	-20	-13	-10	0	10	14	20	30	40	41	45	50
2,000	2.28	2.69	2.87	3.50	4.18	4.49	4.90	5.65	6.45	6.58*	6.87*	7.29*
2,500	2.86	3.41	3.65	4.45	5.26	5.61	6.10	6.94	7.81*	7.94*	8.25*	
3,000	3.52	4.16	4.43	5.37	6.33	6.75	7.31	8.32	9.34*			
3,500	4.20	4.88	5.18	6.24	7.39	7.90*	8.61*	9.91*				

EER (ASHRAE LBP)		12V DC, static cooling										BTU/Wh
rpm \ °F	-20	-13	-10	0	10	14	20	30	40	41	45	50
2,000	3.49	3.89	4.09	4.81	5.57	5.83	6.32	7.00	7.60	7.63*	7.86*	8.09*
2,500	3.47	3.81	3.97	4.58	5.28	5.52	6.05	6.89	7.76*	7.77*	8.21*	
3,000	3.43	3.77	3.93	4.55	5.27	5.52	6.05	6.89	7.76*			
3,500	3.37	3.74	3.91	4.54	5.23	5.46*	5.94*	6.66*				

COP (EN 12900 Household/CECOMAF)		12V DC, static cooling										W/W
rpm \ °F	-20	-13	-10	0	10	14	20	30	40	41	45	50
2,000	0.82	0.92	0.96	1.13	1.31	1.38	1.48	1.64	1.78	1.79*	1.84*	1.90*
2,500	0.82	0.90	0.94	1.08	1.24	1.31	1.42	1.62	1.82	1.89*	1.93*	
3,000	0.81	0.89	0.93	1.07	1.24	1.31	1.42	1.62	1.82*			
3,500	0.80	0.88	0.92	1.07	1.23	1.30*	1.40*	1.56*				

power consumption is limited to 100W with 101N0500 * fan cooling of electronic unit compulsory

Test conditions	EN 12900/CECOMAF	ASHRAE LBP
Condensing temperature	131°F	130°F
Ambient temperature	90°F	90°F
Suction gas temperature	90°F	90°F
Liquid temperature	no subcooling	90°F

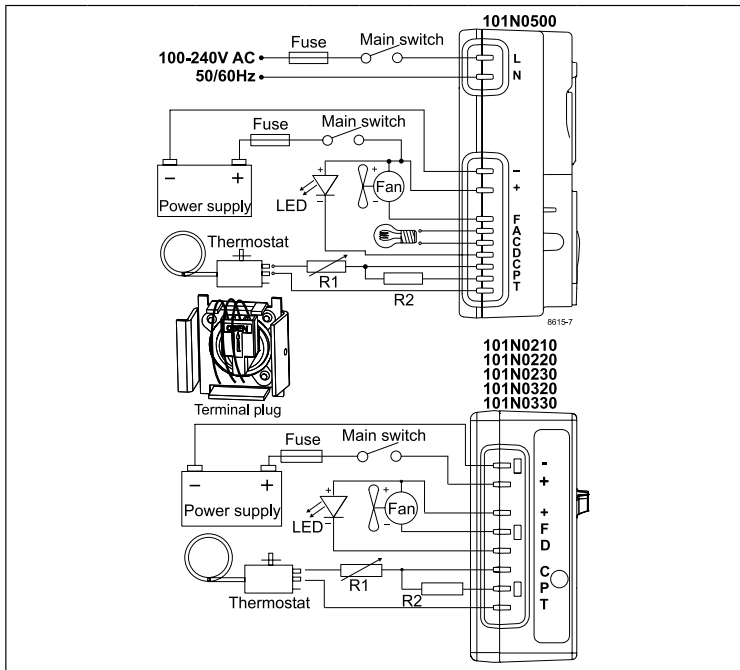

Error code	Error type
5	Thermal cut-out of electronic unit (If the refrigeration system has been too heavily loaded, or if the ambient temperature is high, the electronic unit will run too hot).
4	Minimum motor speed error (If the refrigeration system is too heavily loaded, the motor cannot maintain minimum speed at approximately 1,850 rpm).
3	Motor start error (The rotor is blocked or the differential pressure in the refrigeration system is too high (>5 bar)).
2	Fan over-current cut-out (The fan loads the electronic unit with more than 1A _{peak}).
1	Battery protection cut-out (The voltage is outside the cut-out setting).

Electronit unit	Resistor (R1) [Ω]	Motor speed [rpm]	Control circuit current [mA]
Code number	calculated values		
101N0210	0	2,000	5
101N0220	277	2,500	4
101N0230	692	3,000	3
101N0500	1523	3,500	2
101N0320	0	AEO	6
101N0330	173	2,000	5
101N0330 with AEO	450	2,500	4
	865	3,000	3
	1696	3,500	2

In AEO (Adaptive Energy Optimizing) speed mode the BD compressor will always adapt its speed to the actual cooling demand.

Wire Dimensions DC					
Cross section [mm ²]	Size AWG [Gauge]	Max. length* 12V operation		Max. length* 24V operation	
		[m]	[ft.]	[m]	[ft.]
2.5	12	2.5	8	5	16
4	12	4	13	8	26
6	10	6	20	12	39
10	8	10	33	20	66

*Length between battery and electronic unit

Wire Dimensions AC
Cross section min. 0.75 mm² or AWG 18

Accessories for BD50F	Code number
Bolt joint for one comp.	Ø: 5/8 in. 118-1917
Bolt joint in quantities	Ø: 5/8 in. 118-1918
Snap-on in quantities	Ø: 5/8 in. 118-1919
Remote kit (without cable)	105N9210

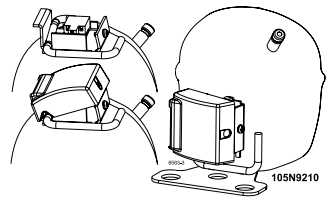

AC line cord UL approved	105N9520
AC line cord VDE approved	105N9530
DC usage:	Automobile fuse 12V: 15A DIN 7258 24V: 7.5 A
	Main switch min. 20A
AC usage:	Fuse, 100-240V min. 4A
	Main switch min. 6A



BD80F Direct Current Compressor R134a 12-24V DC

General

Code number (without electronic units)	101Z0280
Electronic unit - High Speed	101N0290, 28 pcs: 101N0291
Approved compressor - electronic unit combinations	refer to <i>Instructions</i> for 101N0290
Additional approvals	e4, C-Tick
Compressors on pallet	150

Application

Application	LBP
Evaporating temperature °C	-30 to -5
Voltage/max. voltage VDC	9.6 - 17 / 21.3 - 31.5
Max. condensing temperature continuous (short) °C	60 (70)
Max. winding temperature continuous (short) °C	125 (135)

Cooling requirements

Application	LBP	MBP	HBP
32°C	S	-	-
38°C	S	-	-
43°C	S	-	-
Remarks on application:			

Motor

Motor type	variable speed
Resistance, all 3 windings (25°C) Ω	1.8

Design

Displacement cm ³	3.00
Oil quantity (type) cm ³	150 (polyolester)
Maximum refrigerant charge g	300
Free gas volume in compressor cm ³	870
Weight - Compressor/Electronic unit kg	4.4/0.32

Standard battery protection settings (refer to 101N0290 Instructions for optional settings)

Voltage	12V	24V
Cut out VDC	10.4	22.8
Cut in VDC	11.7	24.2

Dimensions

Height	mm	A	137
		B	135
		B1	128
		B2	73
Suction connector	location/I.D. mm angle	C	6.2 40°
	material comment		Cu-plated steel Al cap
Process connector	location/I.D. mm angle	D	6.2 45°
	material comment		Cu-plated steel Al cap
Discharge connector	location/I.D. mm angle	E	5.0 21°
	material comment		Cu-plated steel Al cap
Connector tolerance	I.D. mm		±0.09, on 5.0 +0.12/+0.20
Remarks			

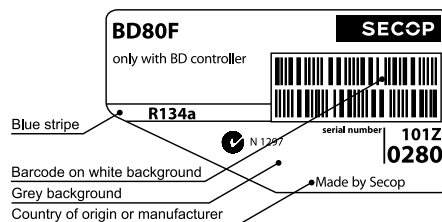

- S = Static cooling normally sufficient
- O = Oil cooling
- F₁ = Fan cooling 1.5 m/s
(compressor compartment temperature equal to ambient temperature)
- F₂ = Fan cooling 3.0 m/s necessary
- SG = Suction gas cooling normally sufficient
- = not applicable in this area

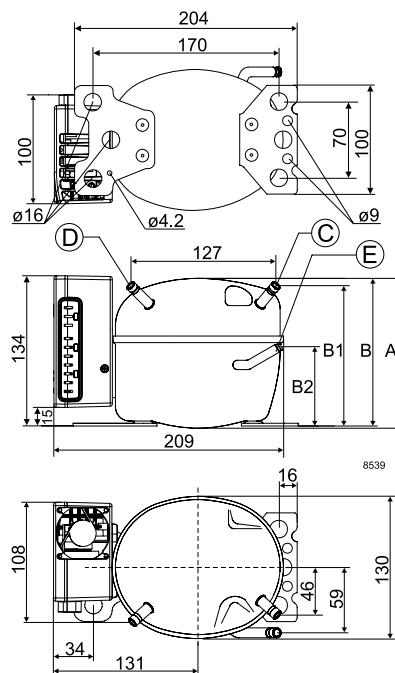

Capacity (EN 12900 Household/CECOMAF) 12V DC, static cooling **watt**

rpm \ °C	-30	-25	-23.3	-20	-15	-10	-5	0	5	7.2	10	15
2,500	35.3	49.5	55.0	66.6	87.1	112	140					
3,100	41.8	59.0	65.6	79.6	104	133	168					
3,800	49.6	70.5	78.5	95.3	125	159	200					
4,400	54.8	78.0	86.7	105	138	176	221					

Capacity (ASHRAE LBP) 12V DC, static cooling **watt**

rpm \ °C	-30	-25	-23.3	-20	-15	-10	-5	0	5	7.2	10	15
2,500	43.5	61.1	67.8	82.2	108	138	174					
3,100	51.5	72.8	80.9	98.2	129	165	207					
3,800	61.1	87.0	96.8	118	154	197	248					
4,400	67.6	96.1	107	130	170	218	274					

Power consumption 12V DC, static cooling **watt**

rpm \ °C	-30	-25	-23.3	-20	-15	-10	-5	0	5	7.2	10	15
2,500	40.0	50.0	53.4	60.3	71.3	83.1	96					
3,100	48.7	61.2	65.4	73.8	87.0	101	118					
3,800	59.5	75.0	80.2	90.3	106	124	145					
4,400	69.0	87.0	93.0	105	123	144	168					

Current consumption (for 24V applications the following must be halved) **A**

rpm \ °C	-30	-25	-23.3	-20	-15	-10	-5	0	5	7.2	10	15
2,500	3.3	4.2	4.5	5.0	5.9	6.9	8.0					
3,100	4.1	5.1	5.5	6.1	7.2	8.5	9.8					
3,800	5.0	6.3	6.7	7.5	8.9	10.3	12.1					
4,400	5.8	7.2	7.7	8.7	10.3	12.0	14.0					

COP (EN 12900 Household/CECOMAF) 12V DC, static cooling **W/W**

rpm \ °C	-30	-25	-23.3	-20	-15	-10	-5	0	5	7.2	10	15
2,500	0.88	0.99	1.03	1.10	1.22	1.34	1.46					
3,100	0.86	0.96	1.00	1.08	1.20	1.31	1.42					
3,800	0.83	0.94	0.98	1.06	1.17	1.28	1.39					
4,400	0.79	0.90	0.93	1.01	1.12	1.22	1.32					

COP (ASHRAE LBP) 12V DC, static cooling **W/W**

rpm \ °C	-30	-25	-23.3	-20	-15	-10	-5	0	5	7.2	10	15
2,500	1.09	1.22	1.27	1.36	1.51	1.66	1.81					
3,100	1.06	1.19	1.24	1.33	1.48	1.62	1.76					
3,800	1.03	1.16	1.21	1.30	1.45	1.59	1.71					
4,400	0.98	1.11	1.15	1.24	1.38	1.51	1.63					

Test conditions	EN 12900/CECOMAF	ASHRAE LBP
Condensing temperature	55°C	54.4°C
Ambient temperature	32°C	32°C
Suction gas temperature	32°C	32°C
Liquid temperature	no subcooling	32°C

Operational errors errors shown by LED (optional)

Error code	Error type
5	Thermal cut-out of electronic unit (If the refrigeration system has been too heavily loaded, or if the ambient temperature is high, the electronic unit will run too hot).
4	Minimum motor speed error (If the refrigeration system is too heavily loaded, the motor cannot maintain minimum speed at approximately 2,450 rpm).
3	Motor start error (The rotor is blocked or the differential pres-sure in the refrigeration system is too high (>5 bar)).
2	Fan over-current cut-out (The fan loads the electronic unit with more than 1A _{peak}).
1	Battery protection cut-out (The voltage is outside the cut-out setting).

Compressor speed

Electronit unit	Resistor (R1) [Ω] calculated values	Motor speed [rpm]	Control circuit current [mA]
101N0290 with AEO	0	AEO	6
	203	2,500	5
	451	3,100	4
	867	3,800	3
	1700	4,400	2

In AEO (Adaptive Energy Optimizing) speed mode the BD compressor will always adapt its speed to the actual cooling demand.

Wire Dimensions DC

Cross section [mm²]	Size AWG [Gauge]	Max. length* 12V operation		Max. length* 24V operation	
		[m]	[ft.]	[m]	[ft.]
6	10	2.5	8	5	16

*Length between battery and electronic unit

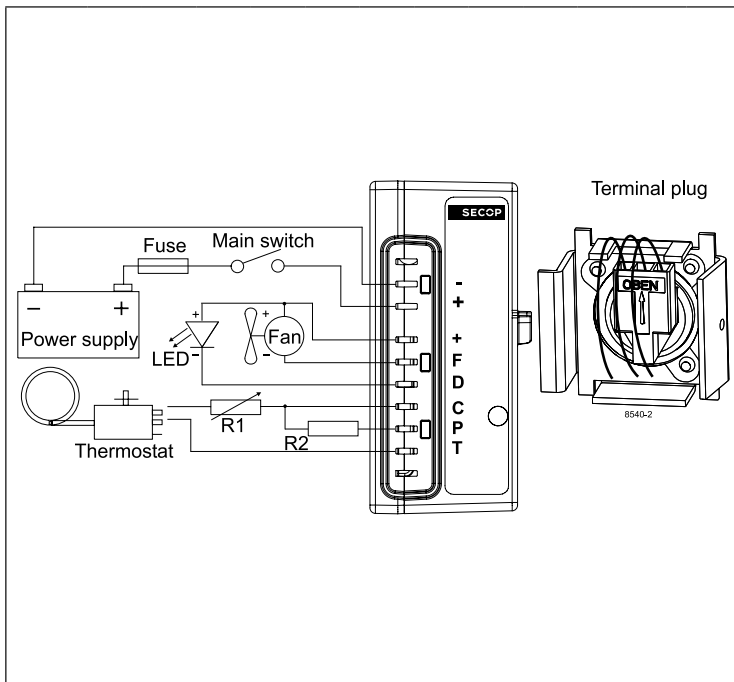

Accessories for BD80F	Code number
Bolt joint for one compressor Ø:16 mm	118-1917
Bolt joint in quantities Ø:16 mm	118-1918
Snap-on in quantities Ø:16 mm	118-1919
Remote kit (without cable)	105N9210

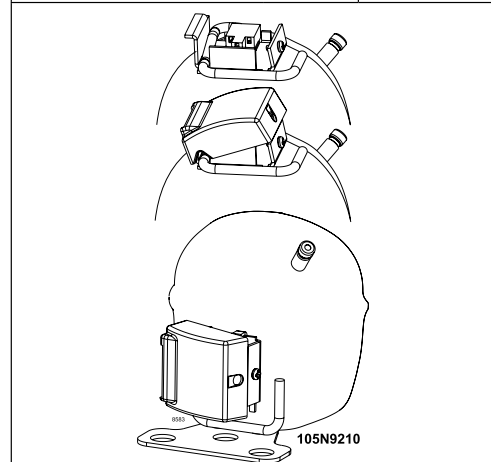

Standard automobile fuse DIN 7258	12V: 30A 24V: 15A	Not deliverable from Secop
Main switch	min. 30A	



BD150F

Variable Speed Drive Compressor

R134a, 160-254V 50-60Hz

12/24V DC with Inverter

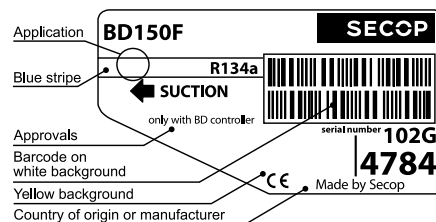

General

Code number (without electronic units)	102G4784
Electronic unit	105N4220
Approvals	EN 60335-2-34 with Annex AA
Compressors on pallet	125

Application

Application	LBP
Evaporating temperature	°C -35 to -10
Voltage range	VAC 160 - 254
	Hz 50 - 60
	VDC 12/24 (see page 2)
Max. condensing temperature continuous (short)	°C 60 (70)
Max. winding temperature continuous (short)	°C 125 (135)

- S = Static cooling normally sufficient
- O = Oil cooling
- F₁ = Fan cooling 1.5 m/s (compressor compartment temperature equal to ambient temperature)
- F₂ = Fan cooling 3.0 m/s necessary
- SG = Suction gas cooling normally sufficient
- = not applicable in this area

Cooling requirements

Application	LBP	MBP	HBP
32°C	S	-	-
38°C	S	-	-
43°C	S	-	-

Remarks on application: HST starting characteristics

Features

Protections	<ul style="list-style-type: none"> • current, voltage, speed, temperature
Usage	<ul style="list-style-type: none"> • mobile refrigeration, designed for use in vans, small trucks, etc. • active refrigeration for food transportation • expanded 230V AC range

Motor

Motor type	permanent magnet
Speed range	rpm 2000 - 4000
LRA (rated after 4 sec. UL984) HST	A electronic cut-off
Cut-in current HST	A 6.0
Resistance, all 3 windings (25°C)	Ω 14.0

Design

Displacement	cm ³	6.49
Oil quantity (type)	cm ³	180 (polyolester)
Maximum refrigerant charge	g	400
Free gas volume in compressor	cm ³	1790
Weight - Compressor/Electronic unit	kg	7.9/0.6

Dimensions

Height	mm	A	173
		B	169
Suction connector	location/I.D. mm angle	C	6.2 30°
	material comment		Cu-plated steel Al cap
Process connector	location/I.D. mm angle	D	6.2 31.5°
	material comment		Cu-plated steel Al cap
Discharge connector	location/I.D. mm angle	E	5.0 28°
	material comment		Cu-plated steel Al cap
Connector tolerance	I.D. mm		±0.09, on 5.0 +0.12/+0.20
Remarks			

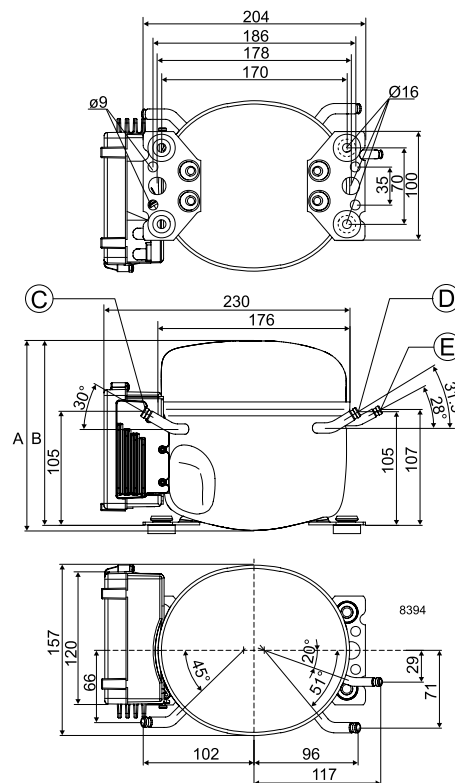

Capacity (EN 12900 Household/CECOMAF) 220V 50 Hz, static cooling watt

rpm \ °C	-35	-30	-25	-23.3	-20	-15	-10
2,000	47.5	66.2	90.0	99.3	120	156	199
2,500	56.3	80.7	111	122	147	192	245
3,000	64.2	92.8	128	141	171	222	284
4,000	78.3	111	153	170	205	269	345

Capacity (ASHRAE LBP) 220V 50 Hz, static cooling watt

rpm \ °C	-35	-30	-25	-23.3	-20	-15	-10
2,000	58.6	81.7	111	123	148	192	246
2,500	69.3	99.5	137	151	182	237	302
3,000	79.1	114	158	175	211	274	350
4,000	96.6	137	189	210	253	332	427

Power consumption 220V 50 Hz, static cooling watt

rpm \ °C	-35	-30	-25	-23.3	-20	-15	-10
2,000	51.8	64.6	78.3	83.3	93.1	109	125
2,500	63.0	79.8	97.6	104	116	136	156
3,000	74.2	94.2	115	123	137	161	185
4,000	96.2	120	146	155	174	203	235

Current consumption 220V 50 Hz, static cooling A

rpm \ °C	-35	-30	-25	-23.3	-20	-15	-10
2,000	0.49	0.63	0.74	0.78	0.85	0.96	1.10
2,500	0.59	0.70	0.84	0.90	1.00	1.12	1.32
3,000	0.69	0.80	0.95	1.02	1.14	1.35	1.55
4,000	0.84	1.05	1.24	1.31	1.45	1.67	1.90

COP (EN 12900 Household/CECOMAF) 220V 50 Hz, static cooling W/W

rpm \ °C	-35	-30	-25	-23.3	-20	-15	-10
2,000	0.92	1.03	1.15	1.19	1.28	1.43	1.59
2,500	0.89	1.01	1.13	1.18	1.27	1.41	1.57
3,000	0.87	0.99	1.11	1.15	1.24	1.38	1.53
4,000	0.81	0.93	1.05	1.09	1.18	1.32	1.47

COP (ASHRAE LBP) 220V 50 Hz, static cooling W/W

rpm \ °C	-35	-30	-25	-23.3	-20	-15	-10
2,000	1.13	1.27	1.42	1.47	1.59	1.77	1.97
2,500	1.10	1.25	1.40	1.45	1.56	1.74	1.94
3,000	1.07	1.22	1.37	1.42	1.53	1.71	1.90
4,000	1.00	1.14	1.29	1.35	1.46	1.63	1.81

Examples of application

Mobile Application
230V AC
Inverter
BD150F
Battery (12/24V DC)

Stationary Application
230V AC
BD150F

Combined Application
230V AC
Inverter
BD150F
Battery (12/24V DC)
Switch
230V AC
8477

Use with 12/24V DC battery in a mobile application is possible by means of an inverter, 12/24V to 230V AC type, min. 300V peak voltage, min. 300W continuous power output.

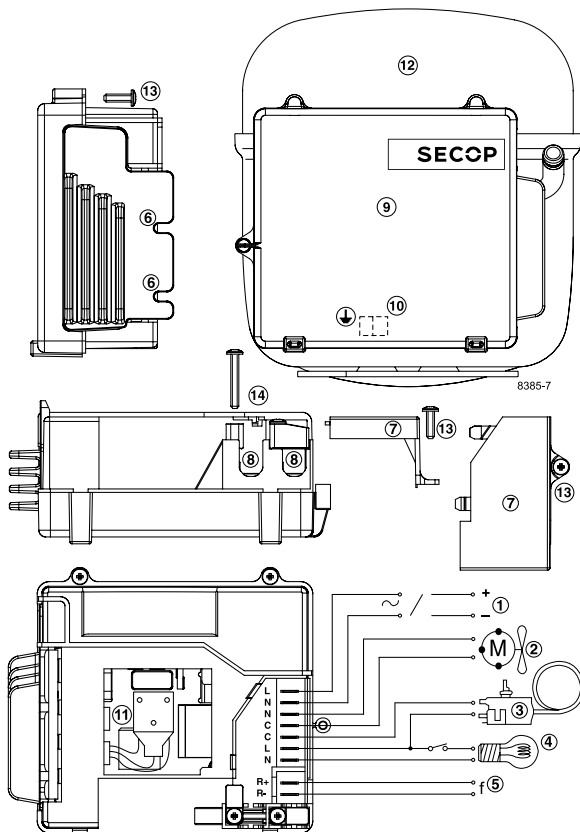

Legend

Number Description

- 1: Power supply
- 2: Fan connection
- 3: Thermostat connection
- 4: Light connection
- 5: Signal input
- 6: Mounting recesses
- 7: Cover
- 8: Cord relief
- 9: Electronic unit
- 10: Earth connection
- 11: Connector
- 12: Compressor
- 13: Screw 3.5 x 12 mm (3 pcs.)
- 14: Screw 3.5 x 25 mm (2 pcs.)

For further descriptions on connecting the electronic unit and the compressor, refer to *Instructions DES.I.100.R "Electronic Unit Type 105N4220, 160-254V, 50-60Hz for BD150F Compressors"*.

Test conditions	EN 12900/CECOMAF	ASHRAE
Condensing temperature	55°C	55°C
Ambient temperature	32°C	32°C
Suction gas temperature	32°C	32°C
Liquid temperature	55°C	32°C

Accessories for	BD150F	Code number
Bolt joint for one compressor	Ø: 16 mm	118-1917
Bolt joint in quantities	Ø: 16 mm	118-1918
Snap-on in quantities	Ø: 16 mm	118-1919



BD250GH.2 Direct Current Compressor R134a 12-24V DC

General

Code number (without electronic units)	101Z0406
Electronic unit - High Speed	101N0290, 28 pcs: 101N0291
Approved compressor - electronic unit combinations	refer to <i>Instructions</i> for 101N0290
Additional approvals	C-Tick
Compressors on pallet	150

Application

Application	LBP/MBP/HBP
Evaporating temperature °C	-25 to 15
Voltage range VDC	9.6 - 17 / 21.3 - 31.5
Max. condensing temperature continuous (short) °C	60 (70)
Max. winding temperature continuous (short) °C	125 (135)

Cooling requirements

Application	LBP	MBP	HBP
32°C	S	S	S
38°C	S	S	S
43°C	S	S	S
Remarks on application:			

Motor

Motor type	variable speed
Resistance, all 3 windings (25°C) Ω	1.8

Design

Displacement cm ³	2.50
Oil quantity (type) cm ³	150 (polyolester)
Maximum refrigerant charge g	300
Free gas volume in compressor cm ³	870
Weight - Compressor/Electronic unit kg	4.4/0.32

Standard battery protection settings (refer to 101N0290 *Instructions* for optional settings)

Voltage	12V	24V
Cut out VDC	10.4	22.8
Cut in VDC	11.7	24.2

Dimensions

Height	mm	A	137
		B	135
		B1	128
		B2	73
Suction connector	location/I.D. mm angle	C	6.2 40°
	material comment		Cu-plated steel Al cap
Process connector	location/I.D. mm angle	D	6.2 45°
	material comment		Cu-plated steel Al cap
Discharge connector	location/I.D. mm angle	E	5.0 21°
	material comment		Cu-plated steel Al cap
Connector tolerance	I.D. mm		±0.09, on 5.0 +0.12/+0.20
Remarks			

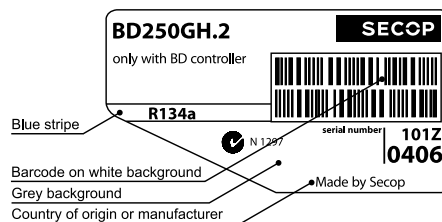

Blue stripe

Barcode on white background

Grey background

Country of origin or manufacturer

serial number 101Z0406

Made by Secop

- S = Static cooling normally sufficient
- O = Oil cooling
- F₁ = Fan cooling 1.5 m/s (compressor compartment temperature equal to ambient temperature)
- F₂ = Fan cooling 3.0 m/s necessary
- SG = Suction gas cooling normally sufficient
- = not applicable in this area

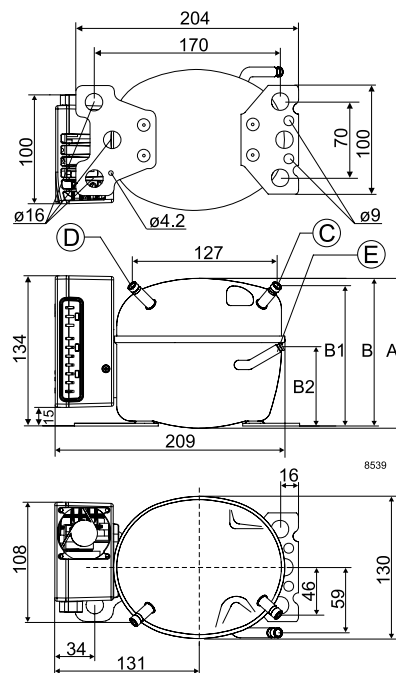

Capacity (EN 12900 Household/CECOMAF) 24V DC, static cooling **watt**

rpm \ °C	-25	-23.3	-20	-15	-10	-6.7	-5	0	5	7.2	10	15
2,500	32.1	36.4	45.9	63.5	85.3	102	112	143	180	197	222	270
3,100	42.9	48.5	61.0	83.5	111	132	143	181	225	246	275	332
3,800	54.6	61.9	77.7	106	140	165	179	225	278	303	338	404
4,400	61.2	69.4	87.2	119	156	184	200	251	308	336	373	446

Capacity (ASHRAE LBP) 24V DC, static cooling **watt**

rpm \ °C	-25	-23.3	-20	-15	-10	-6.7	-5	0	5	7.2	10	15
2,500	39.9	45.3	57.1	79.0	106	127	139	178	224	246	277	338
3,100	53.3	60.4	75.8	104	138	164	178	225	280	307	343	415
3,800	68.0	77.1	96.6	132	173	205	223	280	345	377	420	504
4,400	76.2	86.4	108	148	194	229	248	311	383	418	464	556

Power consumption 24V DC, static cooling **watt**

rpm \ °C	-25	-23.3	-20	-15	-10	-6.7	-5	0	5	7.2	10	15
2,500	35.8	39.6	46.0	53.8	60.1	63.8	65.7	71.3	77.7	80.9	85.6	95.9
3,100	43.8	48.0	55.3	65.0	73.8	79.4	82.3	91.4	102	107	114	130
3,800	57.3	62.0	70.4	82.3	93.9	102	106	119	134	142	152	174
4,400	67.5	72.4	81.5	94.7	108	117	122	138	156	165	177*	202*

Current consumption (for 12V applications the following must be doubled) **A**

rpm \ °C	-25	-23.3	-20	-15	-10	-6.7	-5	0	5	7.2	10	15
2,500	1.67	1.78	1.98	2.25	2.49	2.64	2.71	2.94	3.19	3.31	3.47	3.80
3,100	2.09	2.21	2.45	2.79	3.12	3.35	3.47	3.85	4.27	4.47	4.75	5.31
3,800	2.57	2.71	2.98	3.40	3.85	4.17	4.34	4.90	5.52	5.83	6.24	7.07
4,400	2.85	3.00	3.30	3.76	4.28	4.65	4.86	5.51	6.26	6.63	7.12	8.11

COP (EN 12900 Household/CECOMAF) 24V DC, static cooling **W/W**

rpm \ °C	-25	-23.3	-20	-15	-10	-6.7	-5	0	5	7.2	10	15
2,500	0.90	0.92	1.00	1.18	1.42	1.60	1.70	2.01	2.31	2.44	2.59	2.82
3,100	0.98	1.01	1.10	1.28	1.50	1.66	1.74	1.98	2.21	2.30	2.41	2.56
3,800	0.95	1.00	1.10	1.29	1.49	1.62	1.69	1.89	2.06	2.13	2.21	2.32
4,400	0.91	0.96	1.07	1.25	1.45	1.57	1.64	1.82	1.98	2.04	2.11	2.21

COP (ASHRAE LBP) 24V DC, static cooling **W/W**

rpm \ °C	-25	-23.3	-20	-15	-10	-6.7	-5	0	5	7.2	10	15
2,500	1.11	1.14	1.24	1.47	1.77	2.00	2.13	2.51	2.90	3.06	3.26	3.55
3,100	1.22	1.26	1.37	1.60	1.87	2.07	2.17	2.48	2.77	2.88	3.02	3.21
3,800	1.19	1.24	1.37	1.60	1.85	2.02	2.11	2.36	2.58	2.67	2.77	2.91
4,400	1.13	1.19	1.33	1.56	1.80	1.96	2.04	2.27	2.47	2.55	2.64	2.76

* Possible thermal cut-out of electronic unit due to heavily loaded refrigeration system.

Test conditions	EN 12900/CECOMAF	ASHRAE LBP
Condensing temperature	55°C	54.4°C
Ambient temperature	32°C	32°C
Suction gas temperature	32°C	32°C
Liquid temperature	no subcooling	32°C

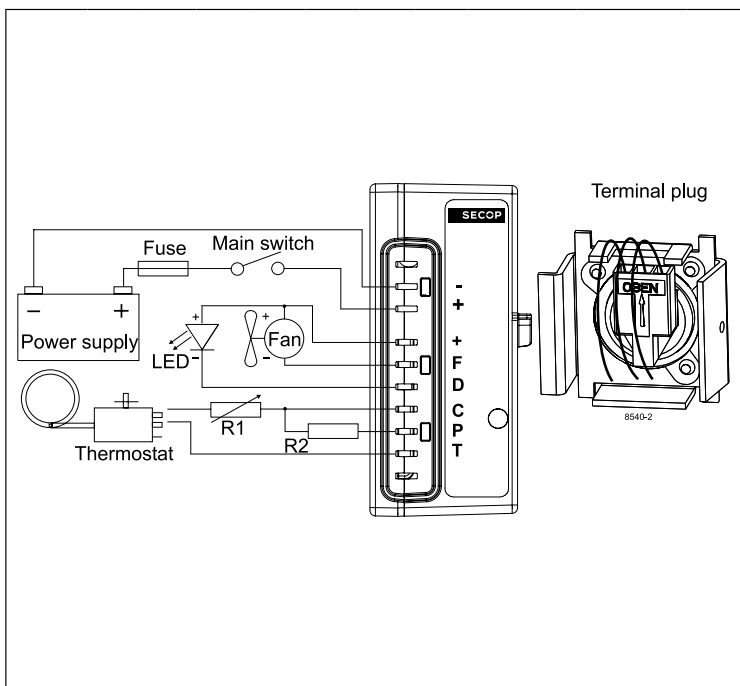

Operational errors errors shown by LED (optional)

Error code	Error type
5	Thermal cut-out of electronic unit (If the refrigeration system has been too heavily loaded, or if the ambient temperature is high, the electronic unit will run too hot).
4	Minimum motor speed error (If the refrigeration system is too heavily loaded, the motor cannot maintain minimum speed at approximately 2,450 rpm).
3	Motor start error (The rotor is blocked or the differential pressure in the refrigeration system is too high (>5 bar)).
2	Fan over-current cut-out (The fan loads the electronic unit with more than 1A _{peak}).
1	Battery protection cut-out (The voltage is outside the cut-out setting).

Compressor speed

Electronit unit	Resistor (R1) [Ω] calculated values	Motor speed [rpm]	Control circuit current [mA]
101N0290 with AEO	0	AEO	6
	203	2,500	5
	451	3,100	4
	867	3,800	3
	1700	4,400	2

In AEO (Adaptive Energy Optimizing) speed mode the BD compressor will always adapt its speed to the actual cooling demand.

Wire Dimensions DC

Cross section [mm ²]	Size AWG [Gauge]	Max. length* 12V operation		Max. length* 24V operation	
		[m]	[ft.]	[m]	[ft.]
6	10	2.5	8	5	16

*Length between battery an electronic unit

Accessories for BD250GH.2	Code number
Bolt joint for one compressor Ø:16 mm	118-1917
Bolt joint in quantities Ø:16 mm	118-1918
Snap-on in quantities Ø:16 mm	118-1919
Remote kit (without cable)	105N9210

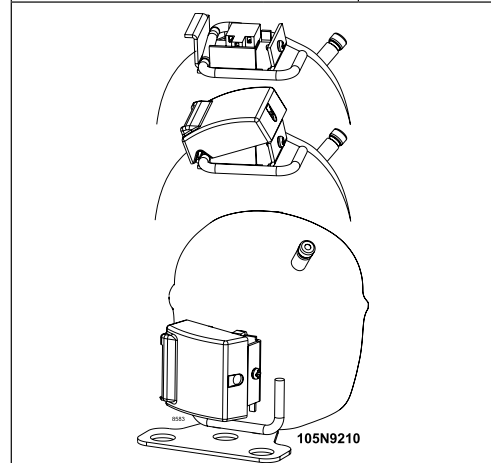

Standard automobile fuse	12V: 30A	Not deliverable from Secop
DIN 7258	24V: 15A	
Main switch	min. 30A	



BD250GH.2 Direct Current Compressor R134a 48V DC



General

Code number (without electronic units)	101Z0405
Electronic unit - Telecom	101N0732, 36 pcs: 101N0733
Approvals	UL
Compressors on pallet	150

Application

Application	LBP/MBP/HBP
Evaporating temperature °C	-25 to 15
Voltage range VDC	32 - 60
Max. condensing temperature continuous (short) °C	60 (70)
Max. winding temperature continuous (short) °C	125 (135)

Cooling requirements

Application	LBP	MBP	HBP
32°C	S	S	S
38°C	S	S	S
43°C	S	S	F ₁
Remarks on application:			

Motor

Motor type	variable speed
Resistance, all 3 windings (25°C) Ω	1.03

Design

Displacement cm ³	2.50
Oil quantity (type) cm ³	150 (polyolester)
Maximum refrigerant charge g	300
Free gas volume in compressor cm ³	870
Weight - Compressor/Electronic unit kg	4.4/0.24

Battery protection settings

Voltage	Min. value	Default	Max. value
Cut out (0.1 steps) VDC	32	36	60
Cut in diff. (0.1 steps) VDC	0.5	4.0	10.0

Dimensions

Height	mm	A	137
		B	135
		B1	128
		B2	73
Suction connector	location/I.D. mm angle	C	6.2 40°
	material comment	Cu-plated steel Al cap	
Process connector	location/I.D. mm angle	D	6.2 45°
	material comment	Cu-plated steel Al cap	
Discharge connector	location/I.D. mm angle	E	5.0 21°
	material comment	Cu-plated steel Al cap	
Connector tolerance	I.D. mm	±0.09, on 5.0 +0.12/+0.20	
Remarks			

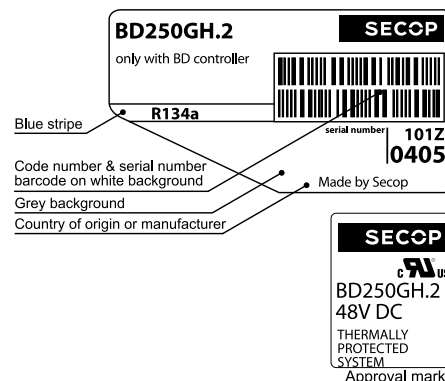

- S = Static cooling normally sufficient
- O = Oil cooling
- F₁ = Fan cooling 1.5 m/s (compressor compartment temperature equal to ambient temperature)
- F₂ = Fan cooling 3.0 m/s necessary
- SG = Suction gas cooling normally sufficient
- = not applicable in this area

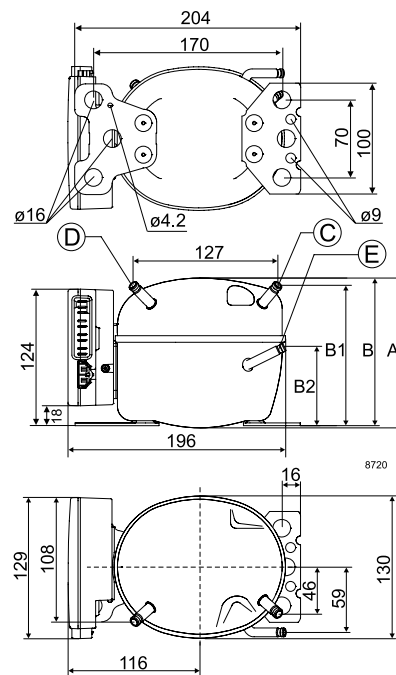

Capacity (EN 12900 Household/CECOMAF) 53V DC, fan cooling F₁ watt

rpm \ °C	-25	-23.3	-20	-15	-10	-6.7	-5	0	5	7.2	10	15
2,500	31.4	36.6	47.2	65.5	87.0	103	112	143	178	195	219	267
3,100	42.9	49.1	62.1	84.8	112	132	144	181	224	246	275	333
3,800	55.0	62.4	78.3	106	139	165	179	224	277	303	337	408
4,400	64.3	72.8	91.1	124	162	191	208	261	322	352	392	472

Capacity (ASHRAE LBP) 53V DC, fan cooling F₁ watt

rpm \ °C	-25	-23.3	-20	-15	-10	-6.7	-5	0	5	7.2	10	15
2,500	40.1	46.3	59.3	81.8	108	129	140	177	222	243	273	334
3,100	54.0	61.6	77.6	106	139	164	178	225	279	306	342	416
3,800	68.7	77.9	97.4	132	173	204	222	279	345	377	421	509
4,400	80.0	90.5	113	153	201	237	257	323	400	437	488	589

Power consumption 53V DC, fan cooling F₁ watt

rpm \ °C	-25	-23.3	-20	-15	-10	-6.7	-5	0	5	7.2	10	15
2,500	40.8	44.1	50.1	58.5	66.0	70.4	72.5	78.5	83.9	86.1	88.7	93.1
3,100	46.5	50.1	57.0	66.9	76.5	82.6	85.7	94.7	103	107	112	121
3,800	58.2	62.2	70.0	81.7	93.7	102	106	119	132	137	145	159
4,400	72.4	76.7	85.3	98.8	113	122	128	143	160	167	177	196

Current consumption 53V DC, fan cooling F₁ A

rpm \ °C	-25	-23.3	-20	-15	-10	-6.7	-5	0	5	7.2	10	15
2,500	0.78	0.86	1.01	1.23	1.43	1.55	1.60	1.75	1.87	1.91	1.95	1.98
3,100	0.65	0.74	0.90	1.14	1.38	1.52	1.59	1.79	1.97	2.04	2.12	2.23
3,800	0.87	0.96	1.13	1.40	1.67	1.85	1.94	2.20	2.45	2.55	2.68	2.89
4,400	1.36	1.45	1.64	1.93	2.24	2.44	2.55	2.86	3.17	3.30	3.47	3.76

COP (EN 12900 Household/CECOMAF) 53V DC, fan cooling F₁ W/W

rpm \ °C	-25	-23.3	-20	-15	-10	-6.7	-5	0	5	7.2	10	15
2,500	0.77	0.83	0.94	1.12	1.32	1.47	1.55	1.82	2.12	2.27	2.47	2.87
3,100	0.92	0.98	1.09	1.27	1.46	1.60	1.67	1.91	2.17	2.29	2.45	2.74
3,800	0.94	1.00	1.12	1.30	1.49	1.62	1.68	1.89	2.11	2.21	2.33	2.57
4,400	0.89	0.95	1.07	1.25	1.44	1.56	1.63	1.82	2.01	2.10	2.21	2.41

COP (ASHRAE LBP) 53V DC, fan cooling F₁ W/W

rpm \ °C	-25	-23.3	-20	-15	-10	-6.7	-5	0	5	7.2	10	15
2,500	0.98	1.05	1.19	1.41	1.66	1.84	1.95	2.28	2.67	2.86	3.12	3.63
3,100	1.16	1.23	1.37	1.59	1.83	2.00	2.09	2.39	2.72	2.87	3.07	3.45
3,800	1.18	1.25	1.40	1.62	1.85	2.01	2.10	2.36	2.64	2.76	2.92	3.22
4,400	1.10	1.18	1.33	1.55	1.79	1.94	2.02	2.27	2.51	2.62	2.76	3.02

Test conditions	EN 12900/CECOMAF	ASHRAE LBP
Condensing temperature	55°C	54.4°C
Ambient temperature	32°C	32°C
Suction gas temperature	32°C	32°C
Liquid temperature	no subcooling	32°C

Operational errors

Error code	Error type
6	Thermostat failure (If the NTC thermistor is short-circuit or has no connection, the electronic unit will enter manual mode).
5	Thermal cut-out of electronic unit (If the refrigeration system has been too heavily loaded, or if the ambient temperature is high, the electronic unit will run too hot).
4	Minimum motor speed error (If the refrigeration system is too heavily loaded, the motor cannot maintain minimum speed at approximately 1,850 rpm).
3	Motor start error (The rotor is blocked or the differential pressure in the refrigeration system is too high).
2	Fan over-current cut-out (The fan loads the electronic unit with more than 1.8A _{peak}).
1	Battery protection cut-out (The voltage is outside the cut-out setting).

Accessories for BD250GH.2

Mounting	Code number
Bolt joint for one compressor Ø: 16 mm	118-1917
Bolt joint in quantities Ø: 16 mm	118-1918
Snap-on in quantities Ø: 16 mm	118-1919

Electrical (cables, sensors, etc.)	Code number	
	Single pack	I - Pack
DC line cord, 900 mm	105N9542	105N9543, 36 pcs.
DC line cord, 2000 mm	105N9540	105N9541, 36 pcs.
DC line cord, 5000 mm	105N9538	105N9539, 36 pcs.
Temperature sensor 470 mm	105N9612	105N9613, 200 pcs.
Temperature sensor 1000 mm	105N9614	105N9615, 100 pcs.
Temperature sensor 1500 mm	105N9616	105N9617, 100 pcs.
One Wire/LIN gateway	105N9501	-
Comm. cable, 1500 mm	-	105N9545, 100 pcs.
Comm. cable, 3000 mm	-	105N9547, 50 pcs.

Not deliverable from Secop	
Slow-blow fuse	16A
Main switch	rated to min. 25A

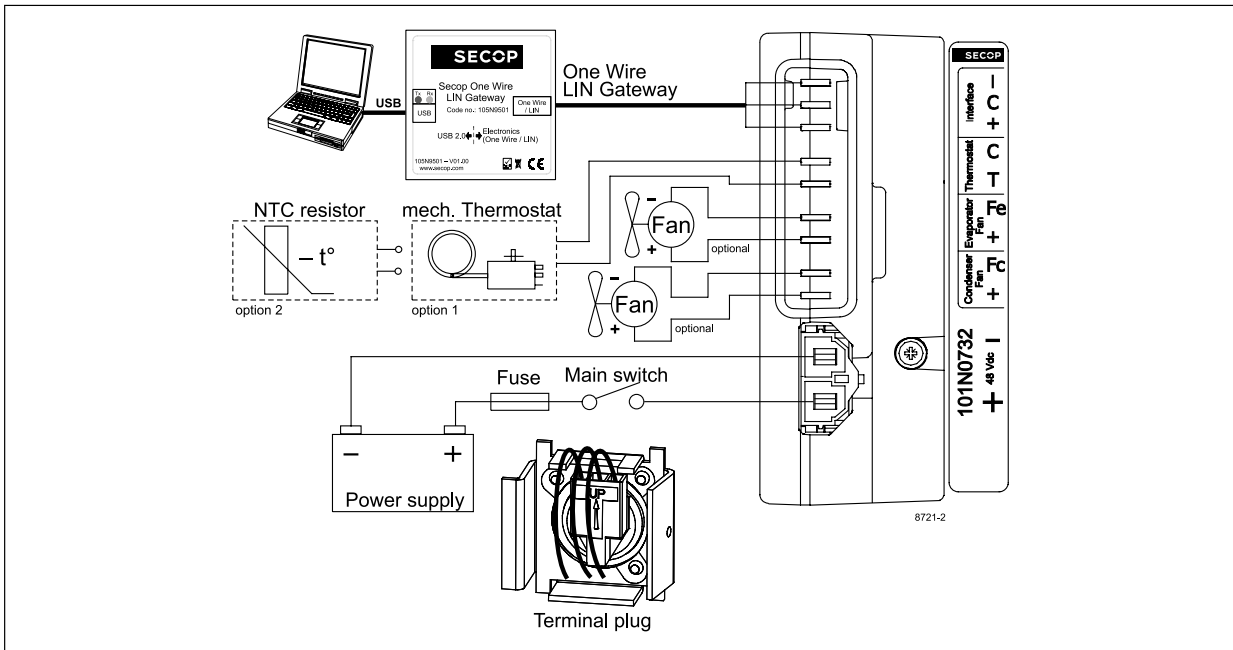



BD350GH

Direct Current Compressor

R134a

12V DC - with 101N08xx Series Controllers

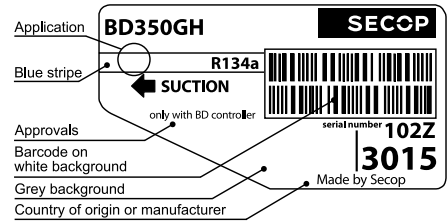

General

Code number (without electronic units)	102Z3015
Compressor module	101N0800, 30 pcs: 101N0801
Application module	101N0820, 24 pcs: 101N0821
Alternative (one interface only): Electronic Unit (no fan connection/no twin option)	101N0830, 30 pcs: 101N0831
Approvals	-
Compressors on pallet	125

Application

Application	LBP/MBP/HBP
Evaporating temperature °C	-25 to 15
Voltage range VDC	9.6 - 17
Max. condensing temperature continuous (short) °C	60 (70)
Max. winding temperature continuous (short) °C	125 (135)

Cooling requirements

Application	LBP	MBP	HBP
32°C	F ₁	F ₁	F ₁
38°C	F ₁	F ₁	F ₁
43°C	F ₁	F ₁	F ₁
Remarks on application: - evaporator fan max. 200W - condenser fan max. 100W - starting ability: LST (low starting torque) only			

Motor

Motor type	Variable speed
Resistance, all 3 windings (25°C) Ω	0.1

Design

Displacement cm ³	5.08
Oil quantity (type) cm ³	280 (polyolester)
Maximum refrigerant charge g	400
Free gas volume in compressor cm ³	1690
Weight - Compressor/Electronic unit kg	7.9 / 0.33 / 0.28 (101N820)

Battery protection settings

Voltage	Min. value	Default	Max. value
Cut out (0.1 steps) VDC	9.6	10.4	17
Cut in diff. (0.1 steps) VDC	0.5	1.3	10

Dimensions

Height	mm	A	173
		B	169
		B1	-
		B2	-
Suction connector	location/I.D. mm angle	C	6.2 90°
		material comment	Cu-plated steel Al cap
Process connector	location/I.D. mm angle	D	6.2 31.5°
		material comment	Cu-plated steel Al cap
Discharge connector	location/I.D. mm angle	E	5.0 28°
		material comment	Cu-plated steel Al cap
Connector tolerance	I.D. mm		±0.09, on 5.0 +0.12/+0.20

- S = Static cooling normally sufficient
- O = Oil cooling
- F₁ = Fan cooling 1.5 m/s
(compressor compartment temperature equal to ambient temperature)
- F₂ = Fan cooling 3.0 m/s necessary
- SG = Suction gas cooling normally sufficient
- = not applicable in this area

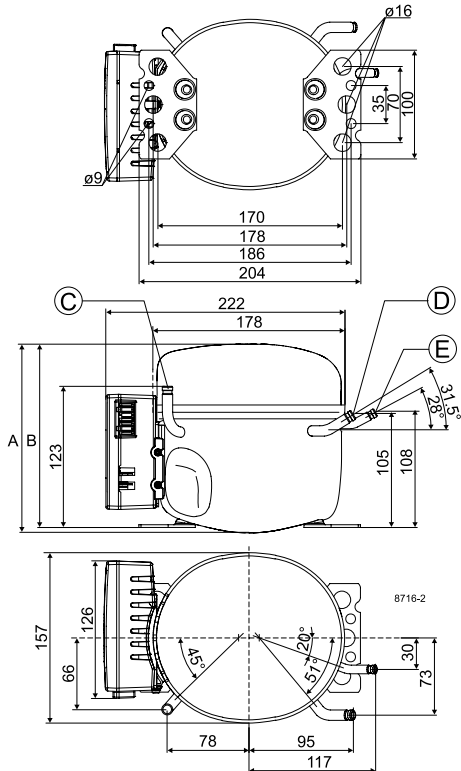



Capacity (EN 12900 Household/CECOMAF) 12V DC, fan cooling F₁ watt

rpm \ °C	-25	-23.3	-20	-15	-10	-6.7	-5	0	5	7.2	10	15
2,500	87.5	96.9	117	152	194	226	244	302	370	403	448	538
3,000	101	112	136	177	225	262	283	351	430	468	521	625
3,500	114	126	152	198	254	296	319	396	485	528	588	706
4,000	126	139	169	220	282	329	355	440	540	588	654	786

Capacity (ASHRAE LBP) 12V DC, fan cooling F₁ watt

rpm \ °C	-25	-23.3	-20	-15	-10	-6.7	-5	0	5	7.2	10	15
2,500	108	120	145	188.3	240	280	302	375	459	501	557	670
3,000	126	139	168	219	279	325	351	435	534	582	648	778
3,500	141	156	188	246	314	366	395	491	602	656	731	879
4,000	156	173	209	273	349	407	440	546	670	731	814	979

Power consumption 12V DC, fan cooling F₁ watt

rpm \ °C	-25	-23.3	-20	-15	-10	-6.7	-5	0	5	7.2	10	15
2,500	90.5	95.6	106	123	140	152	156	177	196	204	215	233
3,000	108	114	127	148	169	184	192	215	238	248	261	284
3,500	122	130	146	170	197	214	224	252	280	292	308	335
4,000	140	149	168	197	228	249	259	292	325	340	358	391

Current consumption 12V DC, fan cooling F₁ A

rpm \ °C	-25	-23.3	-20	-15	-10	-6.7	-5	0	5	7.2	10	15
2,500	7.71	8.15	9.03	10.45	11.93	12.95	13.48	15.06	16.65	17.36	18.25	19.82
3,000	8.99	9.52	10.60	12.32	14.12	15.35	16.00	17.92	19.86	20.71	21.79	23.70
3,500	10.46	11.10	12.39	14.47	16.65	18.13	18.91	21.23	23.57	24.60	25.90	28.21
4,000	11.70	12.46	13.98	16.41	18.97	20.72	21.63	24.35	27.10	28.31	29.84	32.55

COP (EN 12900 Household/CECOMAF) 12V DC, fan cooling F₁ W/W

rpm \ °C	-25	-23.3	-20	-15	-10	-6.7	-5	0	5	7.2	10	15
2,500	0.97	1.01	1.10	1.24	1.38	1.48	1.54	1.71	1.89	1.97	2.09	2.30
3,000	0.94	0.98	1.07	1.20	1.33	1.43	1.48	1.63	1.81	1.89	1.99	2.20
3,500	0.93	0.97	1.04	1.16	1.29	1.38	1.43	1.57	1.73	1.81	1.91	2.10
4,000	0.90	0.93	1.01	1.12	1.24	1.32	1.37	1.51	1.66	1.73	1.83	2.01

COP (ASHRAE LBP) 12V DC, fan cooling F₁ W/W

rpm \ °C	-25	-23.3	-20	-15	-10	-6.7	-5	0	5	7.2	10	15
2,500	1.20	1.26	1.37	1.54	1.72	1.85	1.92	2.13	2.36	2.47	2.61	2.89
3,000	1.17	1.22	1.33	1.49	1.66	1.78	1.84	2.04	2.26	2.36	2.50	2.76
3,500	1.15	1.20	1.30	1.45	1.61	1.72	1.78	1.96	2.17	2.26	2.39	2.64
4,000	1.11	1.16	1.25	1.39	1.54	1.65	1.70	1.88	2.08	2.17	2.29	2.53

Test conditions	EN 12900/CECOMAF	ASHRAE LBP
Condensing temperature	55°C	54.4°C
Ambient temperature	32°C	32°C
Suction gas temperature	32°C	32°C
Liquid temperature	no subcooling	32°C

Operational errors

Error code	Error type
	Can be read out in the software TOOL4COOL®
6	Thermostat failure (If the NTC thermistor is short-circuit or has no connection, the electronic unit will enter manual mode).
5	Thermal cut-out of electronic unit (If the refrigeration system has been too heavily loaded, or if the ambient temperature is high, the electronic unit will run too hot).
4	Minimum motor speed error (If the refrigeration system is too heavily loaded, the motor cannot maintain minimum speed at approximately 1,850 rpm).
3	Motor start error (The rotor is blocked or the differential pressure in the refrigeration system is too high).
2	Fan over-current cut-out (The fan loads the electronic unit with too high current).
1	Battery protection cut-out (The voltage is outside the cut-out setting).

Accessories for BD350GH

Mounting	Code number
Bolt joint for one compressor Ø: 16 mm	118-1917
Bolt joint in quantities Ø: 16 mm	118-1918
Snap-on in quantities Ø: 16 mm	118-1919

Electrical (cables, sensors, etc.)	Code number	
	Single pack	I - Pack
One Wire/LIN gateway	105N9501	-
communication cable	105N9524	-
Bluetooth® gateway	105N9502	-
communication cable	105N9525	-
Temperature sensor 470 mm	105N9612	105N9613, 200 pcs.
Temperature sensor 1000 mm	105N9614	105N9615, 100 pcs.
Temperature sensor 1500 mm	105N9616	105N9617, 100 pcs.
Comm. cable, 1500 mm	-	105N9553, 80 pcs.
Comm. cable, 3000 mm	-	105N9554, 45 pcs.
Display cable, 1500 mm	-	105N9557, 65 pcs.
Display cable, 3000 mm	-	105N9558, 35 pcs.

Not deliverable from Secop	
Slow-blow fuse compressor module	60A
Slow-blow fuse application module	30A
Main switch	rated to min. 100A

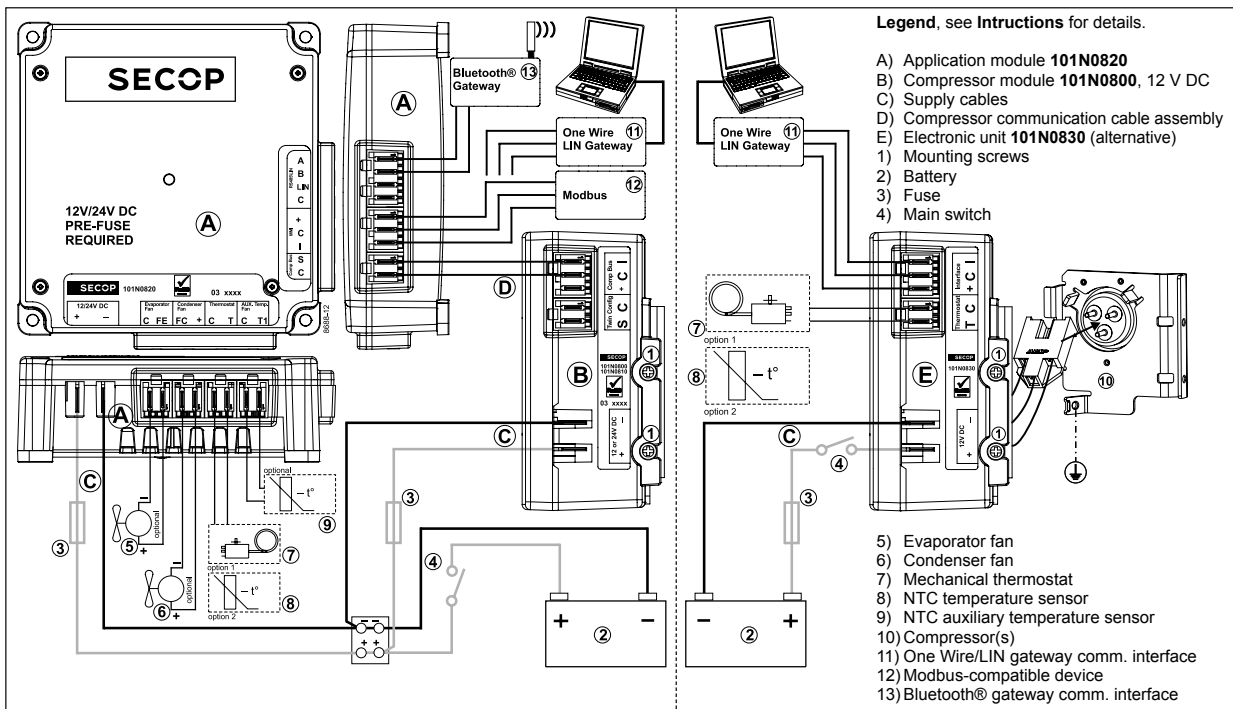



BD350GH Direct Current Compressor R134a 24V DC - with 101N07xx Series Controllers



General

Code number (without electronic units)	102Z3016
Electronic unit	101N0715, 36 pcs: 101N0714
Approvals	-
Compressors on pallet	125

Application

Application	LBP/MBP/HBP
Evaporating temperature °C	-25 to 15
Voltage range VDC	19 - 31.5
Max. condensing temperature continuous (short) °C	60 (70)
Max. winding temperature continuous (short) °C	125 (135)

Cooling requirements

Application	LBP	MBP	HBP
32°C	F ₁	F ₁	F ₁
38°C	F ₁	F ₁	F ₁
43°C	F ₁	F ₁	F ₁

Remarks on application:
 - evaporator fan max. 60W
 - condenser fan max. 40W
 - starting ability: LST (low starting torque) only

Motor

Motor type	variable speed
Resistance, all 3 windings (25°C) Ω	0.2

Design

Displacement cm ³	5.08
Oil quantity (type) cm ³	280 (polyolester)
Maximum refrigerant charge g	400
Free gas volume in compressor cm ³	1690
Weight - Compressor/Electronic unit kg	7.9/0.27

Battery protection settings

Voltage	Min. value	Default	Max. value
Cut out (0.1 steps) VDC	19.0	21.1	27.0
Cut in diff. (0.1 steps) VDC	0.5	3.9	10.0

Dimensions

Height	mm	A	173
		B	169
		B1	-
		B2	-
Suction connector	location/I.D. mm angle	C	6.2 90°
	material comment		Cu-plated steel Al cap
Process connector	location/I.D. mm angle	D	6.2 31.5°
	material comment		Cu-plated steel Al cap
Discharge connector	location/I.D. mm angle	E	5.0 28°
	material comment		Cu-plated steel Al cap
Connector tolerance	I.D. mm		±0.09, on 5.0 +0.12/+0.20
Remarks			

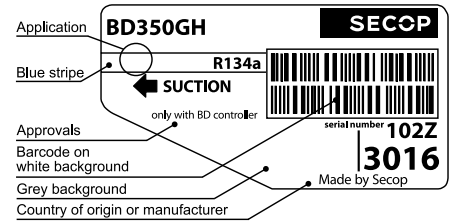

- S = Static cooling normally sufficient
- O = Oil cooling
- F₁ = Fan cooling 1.5 m/s (compressor compartment temperature equal to ambient temperature)
- F₂ = Fan cooling 3.0 m/s necessary
- SG = Suction gas cooling normally sufficient
- = not applicable in this area

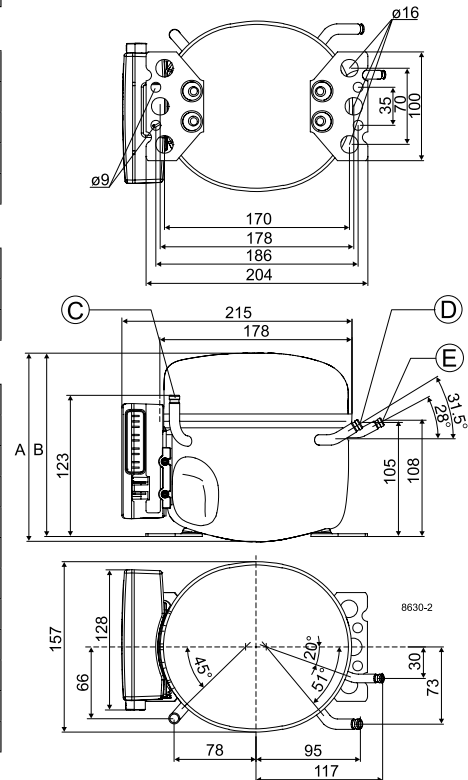

Capacity (EN 12900 Household/CECOMAF) 24V DC, fan cooling F₁ watt

rpm \ °C	-25	-23.3	-20	-15	-10	-6.7	-5	0	5	7.2	10	15
2,500	84.7	93.7	113	147	188	219	236	292	358	390	434	520
3,000	101	112	136	176	225	262	283	351	430	468	521	625
3,500	114	126	152	198	254	296	319	396	485	528	588	706
4,000	126	139	169	220	282	329	355	440	540	588	654	786

Capacity (ASHRAE LBP) 24V DC, fan cooling F₁ watt

rpm \ °C	-25	-23.3	-20	-15	-10	-6.7	-5	0	5	7.2	10	15
2,500	105	116	140	182	233	271	292	363	445	485	539	648
3,000	126	139	168	219	279	325	351	435	534	582	648	779
3,500	141	156	188	246	314	366	395	491	602	656	731	879
4,000	156	173	209	273	349	407	440	546	670	731	814	979

Power consumption 24V DC, fan cooling F₁ watt

rpm \ °C	-25	-23.3	-20	-15	-10	-6.7	-5	0	5	7.2	10	15
2,500	77.4	81.8	90.8	105	120	130	136	152	168	175	184	200
3,000	95.5	101	112	129	148	160	167	186	206	215	226	245
3,500	109	115	128	149	171	186	194	217	241	251	264	288
4,000	122	129	144	169	194	212	221	248	276	288	303	330

Current consumption 24V DC, fan cooling F₁ A

rpm \ °C	-25	-23.3	-20	-15	-10	-6.7	-5	0	5	7.2	10	15
2,500	3.23	3.41	3.78	4.38	5.01	5.43	5.66	6.32	7.00	7.29	7.67	8.33
3,000	3.98	4.20	4.66	5.39	6.15	6.67	6.95	7.76	8.58	8.94	9.40	10.21
3,500	4.52	4.79	5.34	6.21	7.12	7.75	8.08	9.05	10.03	10.46	11.01	11.98
4,000	5.07	5.38	6.02	7.03	8.10	8.82	9.20	10.34	11.48	11.99	12.63	13.75

COP (EN 12900 Household/CECOMAF) 24V DC, fan cooling F₁ W/W

rpm \ °C	-25	-23.3	-20	-15	-10	-6.7	-5	0	5	7.2	10	15
2,500	1.09	1.15	1.25	1.40	1.56	1.68	1.74	1.93	2.13	2.23	2.36	2.60
3,000	1.06	1.11	1.21	1.37	1.53	1.64	1.70	1.88	2.09	2.18	2.31	2.55
3,500	1.05	1.09	1.19	1.33	1.48	1.59	1.65	1.82	2.01	2.10	2.22	2.45
4,000	1.03	1.08	1.17	1.31	1.45	1.55	1.61	1.77	1.96	2.05	2.16	2.38

COP (ASHRAE LBP) 24V DC, fan cooling F₁ W/W

rpm \ °C	-25	-23.3	-20	-15	-10	-6.7	-5	0	5	7.2	10	15
2,500	1.36	1.42	1.55	1.74	1.95	2.09	2.17	2.40	2.67	2.79	2.95	3.27
3,000	1.32	1.38	1.51	1.70	1.90	2.04	2.12	2.35	2.61	2.73	2.89	3.20
3,500	1.30	1.36	1.48	1.66	1.85	1.98	2.05	2.27	2.52	2.63	2.79	3.08
4,000	1.28	1.34	1.45	1.62	1.81	1.93	2.00	2.22	2.45	2.56	2.71	2.99

Test conditions	EN 12900/CECOMAF	ASHRAE LBP
Condensing temperature	55°C	54.4°C
Ambient temperature	32°C	32°C
Suction gas temperature	32°C	32°C
Liquid temperature	no subcooling	32°C

Operational errors

Error code	Error type
	Can be read out in the software TOOL4COOL®
6	Thermostat failure (If the NTC thermistor is short-circuit or has no connection, the electronic unit will enter manual mode).
5	Thermal cut-out of electronic unit (If the refrigeration system has been too heavily loaded, or if the ambient temperature is high, the electronic unit will run too hot).
4	Minimum motor speed error (If the refrigeration system is too heavily loaded, the motor cannot maintain minimum speed at approximately 1,850 rpm).
3	Motor start error (The rotor is blocked or the differential pressure in the refrigeration system is too high).
2	Fan over-current cut-out (The evaporator fan loads the electronic unit with more than 1.8A _{peak} / the condenser fan loads the electronic unit with more than 2.5A _{peak}).
1	Battery protection cut-out (The voltage is outside the cut-out setting).

Accessories for BD350GH

Mounting	Code number
Bolt joint for one compressor Ø: 16 mm	118-1917
Bolt joint in quantities Ø: 16 mm	118-1918
Snap-on in quantities Ø: 16 mm	118-1919

Electrical (cables, sensors, etc.)	Code number	
	Single pack	I - Pack
Temperature sensor 470 mm	105N9612	105N9613, 200 pcs.
Temperature sensor 1000 mm	105N9614	105N9615, 100 pcs.
Temperature sensor 1500 mm	105N9616	105N9617, 100 pcs.
One Wire/LIN gateway	105N9501	-
Comm. cable, 1500 mm	-	105N9545, 100 pcs.
Comm. cable, 3000 mm	-	105N9547, 50 pcs.

Not deliverable from Secop	
Slow-blow fuse	30A
Main switch	rated to min. 50A

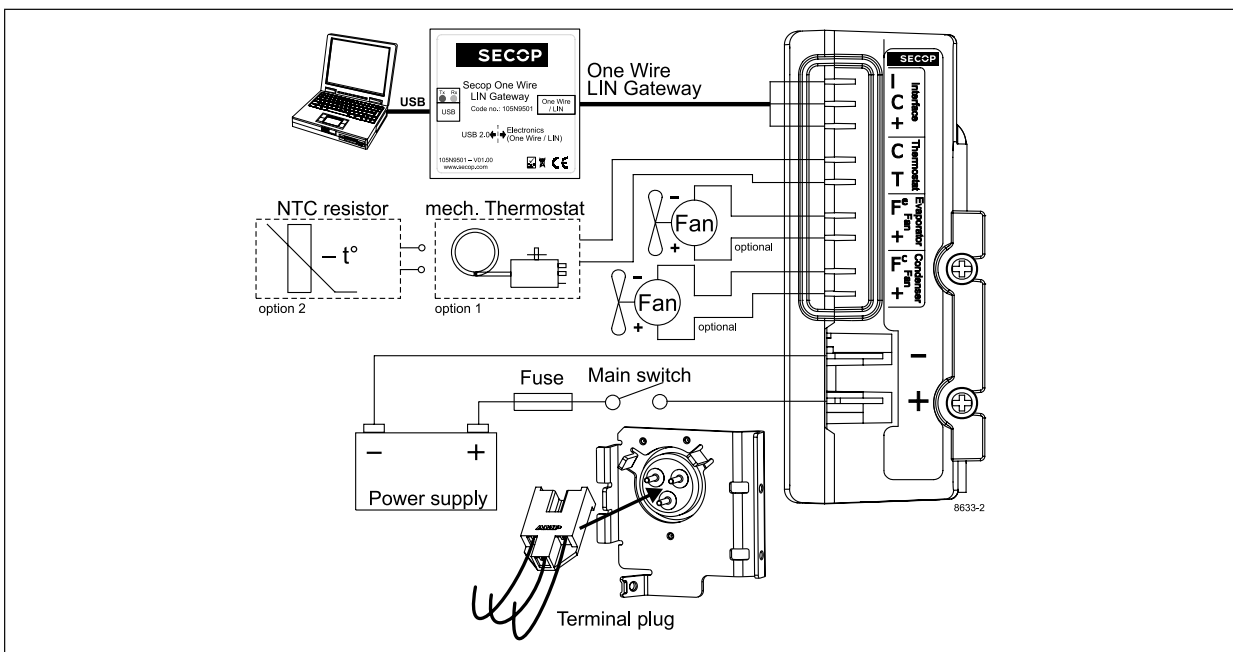



BD350GH Direct Current Compressor R134a 24V DC - with 101N08xx Series Controllers



General

Code number (without electronic units)	102Z3016
Compressor module	101N0810, 30 pcs: 101N0811
Application module	101N0820, 24 pcs: 101N0821
Approvals	-
Compressors on pallet	125

Application

Application	LBP/MBP/HBP
Evaporating temperature °C	-25 to 15
Voltage range VDC	19 - 31.5
Max. condensing temperature continuous (short) °C	60 (70)
Max. winding temperature continuous (short) °C	125 (135)

Cooling requirements

Application	LBP	MBP	HBP
32°C	F ₁	F ₁	F ₁
38°C	F ₁	F ₁	F ₁
43°C	F ₁	F ₁	F ₁

Remarks on application:
 - evaporator fan max. 200W
 - condenser fan max. 100W
 - starting ability: LST (low starting torque) only

Motor

Motor type	Variable speed
Resistance, all 3 windings (25°C) Ω	0.1

Design

Displacement cm ³	5.08
Oil quantity (type) cm ³	280 (polyolester)
Maximum refrigerant charge g	400
Free gas volume in compressor cm ³	1690
Weight - Compressor/Electronic unit kg	7.9 / 0.25 / 0.28 (101N820)

Battery protection settings

Voltage	Min. value	Default	Max. value
Cut out (0.1 steps) VDC	19.0	21.1	27.0
Cut in diff. (0.1 steps) VDC	0.5	3.9	10.0

Dimensions

Height mm	A	173
	B	169
	B1	-
	B2	-
Suction connector location/I.D. mm angle	C	6.2 90°
material comment		Cu-plated steel Al cap
Process connector location/I.D. mm angle	D	6.2 31.5°
material comment		Cu-plated steel Al cap
Discharge connector location/I.D. mm angle	E	5.0 28°
material comment		Cu-plated steel Al cap
Connector tolerance I.D. mm		±0.09, on 5.0 +0.12/+0.20

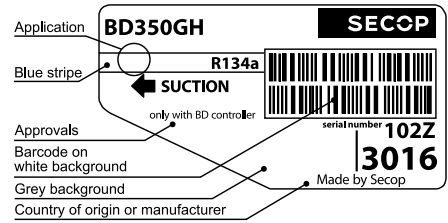

- S = Static cooling normally sufficient
- O = Oil cooling
- F₁ = Fan cooling 1.5 m/s (compressor compartment temperature equal to ambient temperature)
- F₂ = Fan cooling 3.0 m/s necessary
- SG = Suction gas cooling normally sufficient
- = not applicable in this area

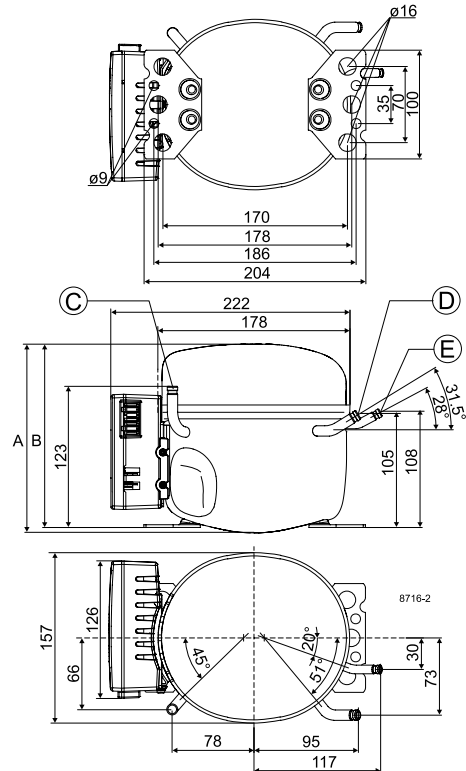

Capacity (EN 12900 Household/CECOMAF) 24V DC, fan cooling F₁ **watt**

rpm \ °C	-25	-23.3	-20	-15	-10	-6.7	-5	0	5	7.2	10	15
2,500	84.7	93.7	113	147	188	219	236	292	358	390	434	520
3,000	101	112	136	176	225	262	283	351	430	468	521	625
3,500	114	126	152	198	254	296	319	396	485	528	588	706
4,000	126	139	169	220	282	329	355	440	540	588	654	786

Capacity (ASHRAE LBP) 24V DC, fan cooling F₁ **watt**

rpm \ °C	-25	-23.3	-20	-15	-10	-6.7	-5	0	5	7.2	10	15
2,500	105	116	140	182	233	271	292	363	445	485	539	648
3,000	126	139	168	219	279	325	351	435	534	582	648	779
3,500	141	156	188	246	314	366	395	491	602	656	731	879
4,000	156	173	209	273	349	407	440	546	670	731	814	979

Power consumption 24V DC, fan cooling F₁ **watt**

rpm \ °C	-25	-23.3	-20	-15	-10	-6.7	-5	0	5	7.2	10	15
2,500	77.4	81.8	90.8	105	120	130	136	152	168	175	184	200
3,000	95.5	101	112	129	148	160	167	186	206	215	226	245
3,500	109	115	128	149	171	186	194	217	241	251	264	288
4,000	122	129	144	169	194	212	221	248	276	288	303	330

Current consumption 24V DC, fan cooling F₁ **A**

rpm \ °C	-25	-23.3	-20	-15	-10	-6.7	-5	0	5	7.2	10	15
2,500	3.23	3.41	3.78	4.38	5.01	5.43	5.66	6.32	7.00	7.29	7.67	8.33
3,000	3.98	4.20	4.66	5.39	6.15	6.67	6.95	7.76	8.58	8.94	9.40	10.21
3,500	4.52	4.79	5.34	6.21	7.12	7.75	8.08	9.05	10.03	10.46	11.01	11.98
4,000	5.07	5.38	6.02	7.03	8.10	8.82	9.20	10.34	11.48	11.99	12.63	13.75

COP (EN 12900 Household/CECOMAF) 24V DC, fan cooling F₁ **W/W**

rpm \ °C	-25	-23.3	-20	-15	-10	-6.7	-5	0	5	7.2	10	15
2,500	1.09	1.15	1.25	1.40	1.56	1.68	1.74	1.93	2.13	2.23	2.36	2.60
3,000	1.06	1.11	1.21	1.37	1.53	1.64	1.70	1.88	2.09	2.18	2.31	2.55
3,500	1.05	1.09	1.19	1.33	1.48	1.59	1.65	1.82	2.01	2.10	2.22	2.45
4,000	1.03	1.08	1.17	1.31	1.45	1.55	1.61	1.77	1.96	2.05	2.16	2.38

COP (ASHRAE LBP) 24V DC, fan cooling F₁ **W/W**

rpm \ °C	-25	-23.3	-20	-15	-10	-6.7	-5	0	5	7.2	10	15
2,500	1.36	1.42	1.55	1.74	1.95	2.09	2.17	2.40	2.67	2.79	2.95	3.27
3,000	1.32	1.38	1.51	1.70	1.90	2.04	2.12	2.35	2.61	2.73	2.89	3.20
3,500	1.30	1.36	1.48	1.66	1.85	1.98	2.05	2.27	2.52	2.63	2.79	3.08
4,000	1.28	1.34	1.45	1.62	1.81	1.93	2.00	2.22	2.45	2.56	2.71	2.99

Test conditions	EN 12900/CECOMAF	ASHRAE LBP
Condensing temperature	55°C	54.4°C
Ambient temperature	32°C	32°C
Suction gas temperature	32°C	32°C
Liquid temperature	no subcooling	32°C

Operational errors

Error code	Error type
	Can be read out in the software TOOL4COOL®
6	Thermostat failure (If the NTC thermistor is short-circuit or has no connection, the electronic unit will enter manual mode).
5	Thermal cut-out of electronic unit (If the refrigeration system has been too heavily loaded, or if the ambient temperature is high, the electronic unit will run too hot).
4	Minimum motor speed error (If the refrigeration system is too heavily loaded, the motor cannot maintain minimum speed at approximately 1,850 rpm).
3	Motor start error (The rotor is blocked or the differential pressure in the refrigeration system is too high).
2	Fan over-current cut-out (The fan loads the electronic unit with too high current).
1	Battery protection cut-out (The voltage is outside the cut-out setting).

Accessories for BD350GH

Mounting	Code number
Bolt joint for one compressor Ø: 16 mm	118-1917
Bolt joint in quantities Ø: 16 mm	118-1918
Snap-on in quantities Ø: 16 mm	118-1919

Electrical (cables, sensors, etc.)	Code number	
	Single pack	I - Pack
One Wire/LIN gateway communication cable	105N9501	-
Bluetooth® gateway communication cable	105N9502	-
Temperature sensor 470 mm	105N9612	105N9613, 200 pcs.
Temperature sensor 1000 mm	105N9614	105N9615, 100 pcs.
Temperature sensor 1500 mm	105N9616	105N9617, 100 pcs.
Comm. cable, 1500 mm	-	105N9553, 80 pcs.
Comm. cable, 3000 mm	-	105N9554, 45 pcs.
Display cable, 1500 mm	-	105N9557, 65 pcs.
Display cable, 3000 mm	-	105N9558, 35 pcs.

Not deliverable from Secop	
Slow-blow fuse compressor module	60A
Slow-blow fuse application module	30A
Main switch	rated to min. 100A

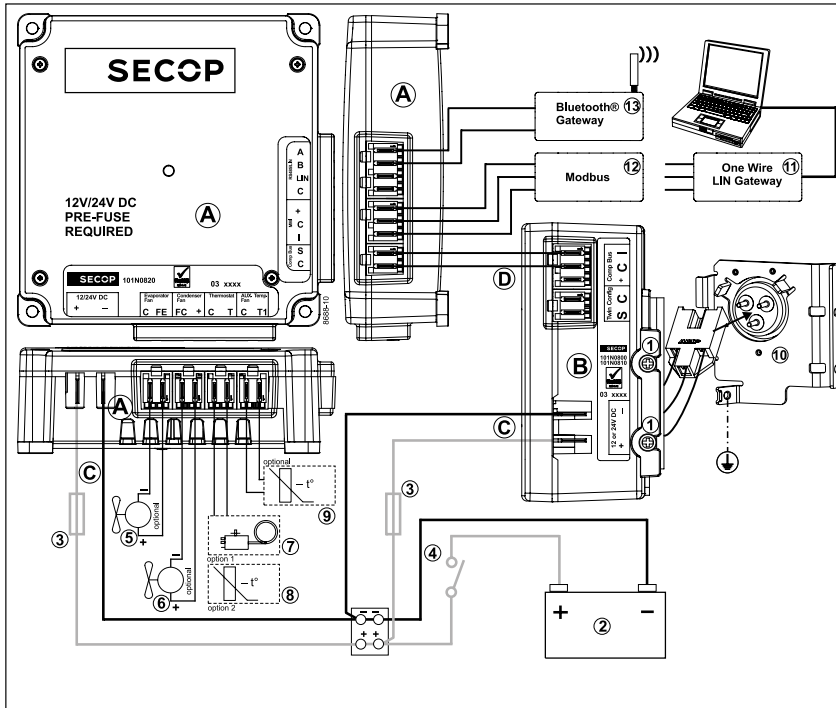

- Legend, see Instructions for details.**
- A) Application module **101N0820**
 - B) Compressor module **101N0810**, 24 V DC
 - C) Supply cables
 - D) Compressor communication cable assembly
- 1) Mounting screws
 - 2) Battery
 - 3) Fuse
 - 4) Main switch
 - 5) Evaporator fan
 - 6) Condenser fan
 - 7) Mechanical thermostat
 - 8) NTC temperature sensor
 - 9) NTC auxiliary temperature sensor
 - 10) Compressor(s)
 - 11) One Wire/LIN gateway comm. interface
 - 12) Modbus-compatible device
 - 13) Bluetooth® gateway comm. interface



BD350GH Direct Current Compressor R134a 48-56V DC



General

Code number (without electronic units)	102Z3031
Electronic unit - Telecom	101N0720, 36 pcs: 101N0721
Approvals	UL
Compressors on pallet	125

Application

Application	LBP/MBP/HBP
Evaporating temperature °C	-25 to 15
Voltage range VDC	32 - 60
Max. condensing temperature continuous (short) °C	60 (70)
Max. winding temperature continuous (short) °C	125 (135)

Cooling requirements

Application	LBP	MBP	HBP
32°C	F ₁	F ₁	F ₁
38°C	F ₁	F ₁	F ₁
43°C	F ₁	F ₁	F ₁

Remarks on application:
 - evaporator fan max. 60W
 - condenser fan max. 40W
 - starting ability: LST (low starting torque) only

Motor

Motor type	variable speed
Resistance, all 3 windings (25°C) Ω	0.4

Design

Displacement cm ³	5.08
Oil quantity (type) cm ³	280 (polyolester)
Maximum refrigerant charge g	400
Free gas volume in compressor cm ³	1690
Weight - Compressor/Electronic unit kg	7.9/0.27

Battery protection settings

Voltage	Min. value	Default	Max. value
Cut out (0.1 steps) VDC	32	36	60
Cut in diff. (0.1 steps) VDC	0.5	4.0	10.0

Dimensions

Height	mm	A	173
		B	169
		B1	-
		B2	-
Suction connector	location/I.D. mm angle	C	6.2 90°
	material comment		Cu-plated steel Al cap
Process connector	location/I.D. mm angle	D	6.2 31.5°
	material comment		Cu-plated steel Al cap
Discharge connector	location/I.D. mm angle	E	5.0 28°
	material comment		Cu-plated steel Al cap
Connector tolerance	I.D. mm		±0.09, on 5.0 +0.12/+0.20
Remarks			

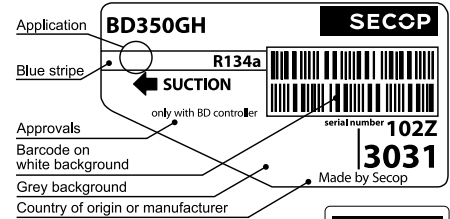

- S = Static cooling normally sufficient
- O = Oil cooling
- F₁ = Fan cooling 1.5 m/s
(compressor compartment temperature equal to ambient temperature)
- F₂ = Fan cooling 3.0 m/s necessary
- SG = Suction gas cooling normally sufficient
- = not applicable in this area

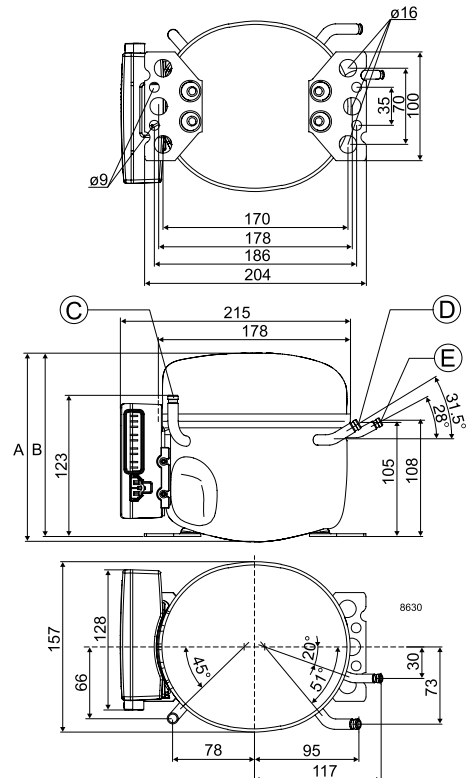

Capacity (EN 12900 Household/CECOMAF) 56V DC, fan cooling F_1 **watt**

rpm \ °C	-25	-23.3	-20	-15	-10	-6.7	-5	0	5	7.2	10	15
2,500	84.7	93.7	113	147	188	219	236	292	358	390	434	520
3,000	101	112	135	176	224	261	282	349	428	466	518	622
3,500	112	125	151	196	251	293	316	392	480	523	582	698
4,000	121	135	164	216	277	324	350	436	535	584	650	781

Capacity (ASHRAE LBP) 56V DC, fan cooling F_1 **watt**

rpm \ °C	-25	-23.3	-20	-15	-10	-6.7	-5	0	5	7.2	10	15
2,500	105	116	140	182	233	271	292	363	444	484	539	648
3,000	125	138	167	217	278	324	349	433	531	579	644	775
3,500	139	154	186	243	311	362	391	486	596	650	723	870
4,000	150	167	203	267	343	401	434	540	664	725	808	973

Power consumption 56V DC, fan cooling F_1 **watt**

rpm \ °C	-25	-23.3	-20	-15	-10	-6.7	-5	0	5	7.2	10	15
2,500	85.2	89.6	98.3	112	127	137	142	158	174	181	190	205
3,000	95.0	100	111	129	147	159	166	185	205	214	225	244
3,500	107	114	127	147	169	184	192	215	238	249	262	285
4,000	131	139	155	181	208	226	236	265	294	307	323	352

Current consumption 56V DC, fan cooling F_1 **A**

rpm \ °C	-25	-23.3	-20	-15	-10	-6.7	-5	0	5	7.2	10	15
2,500	1.52	1.60	1.76	2.01	2.27	2.45	2.54	2.82	3.11	3.23	3.39	3.67
3,000	1.70	1.79	1.99	2.30	2.62	2.85	2.96	3.31	3.66	3.81	4.01	4.35
3,500	1.92	2.03	2.26	2.63	3.02	3.29	3.43	3.84	4.26	4.44	4.67	5.08
4,000	2.34	2.48	2.77	3.23	3.71	4.04	4.22	4.73	5.25	5.48	5.77	6.28

COP (EN 12900 Household/CECOMAF) 56V DC, fan cooling F_1 **W/W**

rpm \ °C	-25	-23.3	-20	-15	-10	-6.7	-5	0	5	7.2	10	15
2,500	0.99	1.05	1.15	1.31	1.48	1.59	1.66	1.85	2.06	2.16	2.29	2.53
3,000	1.06	1.11	1.21	1.37	1.53	1.64	1.70	1.88	2.09	2.18	2.31	2.55
3,500	1.05	1.09	1.19	1.33	1.48	1.59	1.65	1.82	2.01	2.10	2.22	2.45
4,000	0.92	0.97	1.06	1.19	1.33	1.43	1.48	1.64	1.82	1.90	2.01	2.22

COP (ASHRAE LBP) 56V DC, fan cooling F_1 **W/W**

rpm \ °C	-25	-23.3	-20	-15	-10	-6.7	-5	0	5	7.2	10	15
2,500	1.23	1.30	1.43	1.63	1.84	1.98	2.06	2.31	2.57	2.70	2.86	3.18
3,000	1.32	1.38	1.51	1.70	1.90	2.04	2.12	2.35	2.61	2.73	2.89	3.20
3,500	1.30	1.36	1.48	1.66	1.85	1.98	2.05	2.27	2.52	2.63	2.79	3.08
4,000	1.15	1.21	1.31	1.48	1.66	1.78	1.85	2.05	2.28	2.38	2.52	2.79

Test conditions	EN 12900/CECOMAF	ASHRAE LBP
Condensing temperature	55°C	54.4°C
Ambient temperature	32°C	32°C
Suction gas temperature	32°C	32°C
Liquid temperature	no subcooling	32°C

Operational errors

Error code	Error type
	Can be read out in the software TOOL4COOL®
6	Thermostat failure (If the NTC thermistor is short-circuit or has no connection, the electronic unit will enter manual mode).
5	Thermal cut-out of electronic unit (If the refrigeration system has been too heavily loaded, or if the ambient temperature is high, the electronic unit will run too hot).
4	Minimum motor speed error (If the refrigeration system is too heavily loaded, the motor cannot maintain minimum speed at approximately 1,850 rpm).
3	Motor start error (The rotor is blocked or the differential pressure in the refrigeration system is too high).
2	Fan over-current cut-out (The fan loads the electronic unit with more than 1.8A _{peak}).
1	Battery protection cut-out (The voltage is outside the cut-out setting).

Accessories for BD350GH

Mounting	Code number
Bolt joint for one compressor Ø: 16 mm	118-1917
Bolt joint in quantities Ø: 16 mm	118-1918
Snap-on in quantities Ø: 16 mm	118-1919

Electrical (cables, sensors, etc.)	Code number	
	Single pack	I - Pack
DC line cord, 900 mm	105N9542	105N9543, 36 pcs.
DC line cord, 2000 mm	105N9540	105N9541, 36 pcs.
DC line cord, 5000 mm	105N9538	105N9539, 36 pcs.
Temperature sensor 470 mm	105N9612	105N9613, 200 pcs.
Temperature sensor 1000 mm	105N9614	105N9615, 100 pcs.
Temperature sensor 1500 mm	105N9616	105N9617, 100 pcs.
One Wire/LIN gateway	105N9501	-
Comm. cable, 1500 mm	-	105N9545, 100 pcs.
Comm. cable, 3000 mm	-	105N9547, 50 pcs.

Not deliverable from Secop	
Slow-blow fuse	16A
Main switch	rated to min. 25A

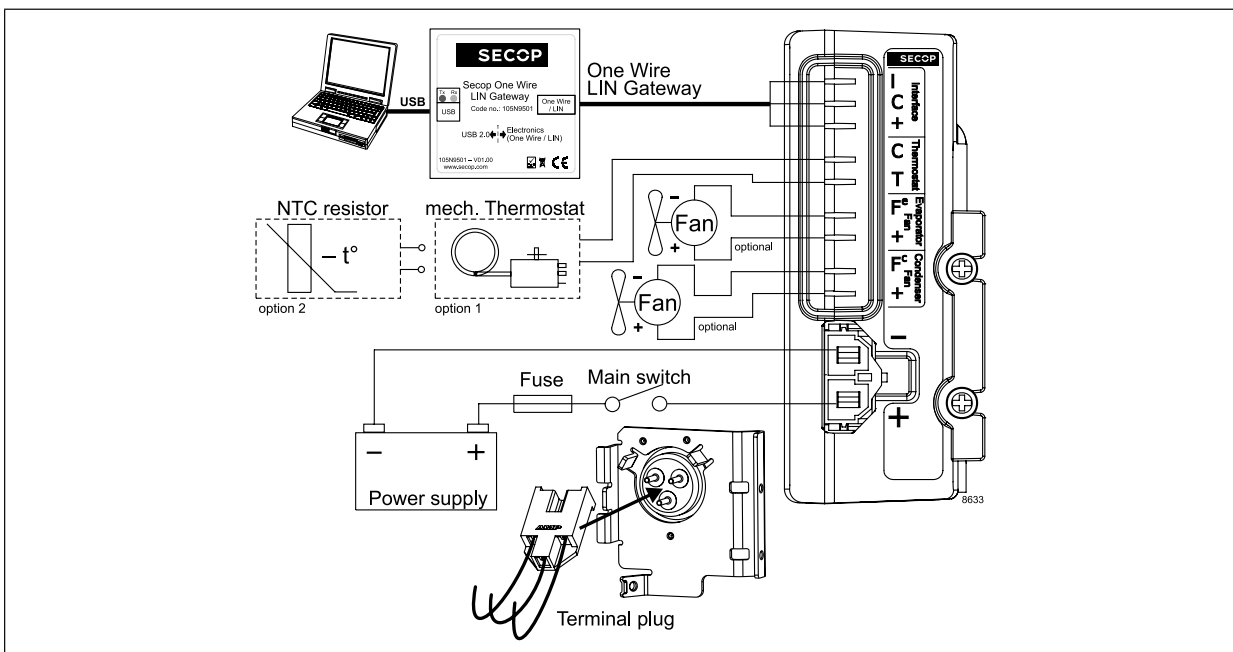



BD350/350GH

Direct Current Twin Compressor

R134a

12V - with 101N08xx Series Controllers

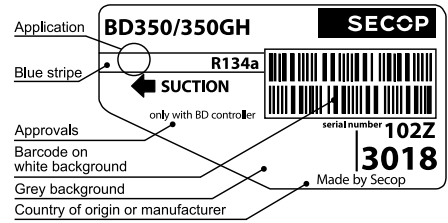

General

Code number (without electronic units)	102Z3018
Compressor module	101N0800, 30 pcs: 101N0801
Application module	101N0820, 24 pcs: 101N0821
Approvals	-
Compressors on pallet	50

Application

Application	LBP/MBP/HBP
Evaporating temperature °C	-25 to 15
Voltage range VDC	9.6 - 17
Max. condensing temperature continuous (short) °C	60 (70)
Max. winding temperature continuous (short) °C	125 (135)

Cooling requirements

Application	LBP	MBP	HBP
32°C	F ₁	F ₁	F ₁
38°C	F ₁	F ₁	F ₁
43°C	F ₁	F ₁	F ₁

Remarks on application:
 - evaporator fan max. 200W
 - condenser fan max. 100W
 - starting ability: LST (low starting torque) only

Motor

Motor type	variable speed
Resistance, all 3 windings (25°C) Ω	0.1

Design

Displacement cm ³	2 x 5.08
Oil quantity (type) cm ³	560 (polyolester)
Maximum refrigerant charge g	800
Free gas volume in compressor cm ³	2 x 1690
Weight - Compressor/Electronic unit kg	15.8/2 x 0.33, 1 x 0.28

Battery protection settings

Voltage	Min. value	Default	Max. value
Cut out (0.1 steps) VDC	9.6	10.4	17
Cut in diff. (0.1 steps) VDC	0.5	1.3	10

Dimensions

Height	mm	A	173
		B	169
		B1	-
		B2	-
Suction connector	location/I.D. mm angle	C	6.2 90°
	material comment		Cu-plated steel Al cap
Process connector	location/I.D. mm angle	D	6.2 31.5°
	material comment		Cu-plated steel Al cap
Discharge connector	location/I.D. mm angle	E	5.0 28°
	material comment		Cu-plated steel Al cap
Connector tolerance	I.D. mm		±0.09, on 5.0 +0.12/+0.20
Remarks			

- S = Static cooling normally sufficient
- O = Oil cooling
- F₁ = Fan cooling 1.5 m/s (compressor compartment temperature equal to ambient temperature)
- F₂ = Fan cooling 3.0 m/s necessary
- SG = Suction gas cooling normally sufficient
- = not applicable in this area

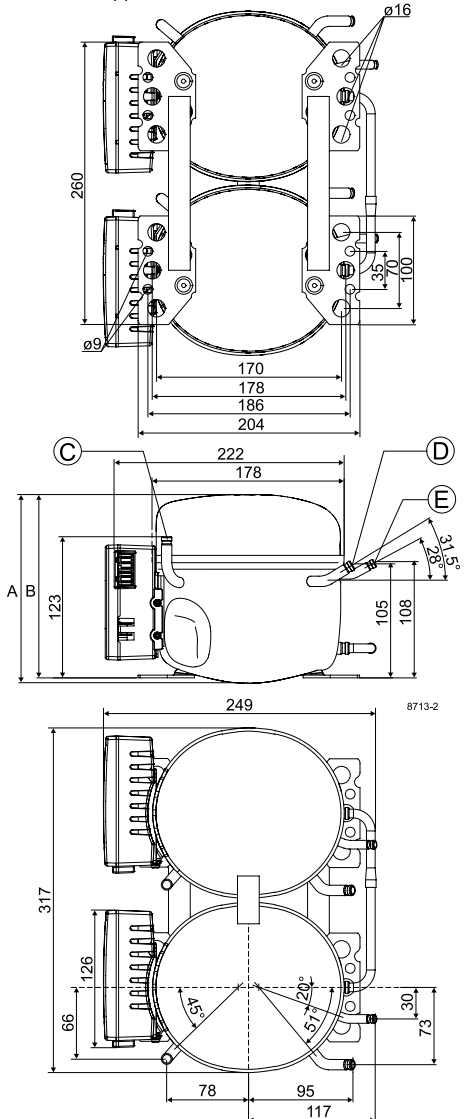

Capacity (EN 12900 Household/CECOMAF) 12V DC, fan cooling F₁ **watt**

rpm \ °C	-25	-23.3	-20	-15	-10	-6.7	-5	0	5	7.2	10	15
2,500	175	194	234	304	388	452	488	604	740	806	896	1076
3,000	203	225	271	353	450	524	566	702	860	936	1042	1250
3,500	227	252	304	396	508	592	638	792	970	1056	1176	1412
4,000	251	279	337	440	564	658	710	880	1080	1176	1308	1572

Capacity (ASHRAE LBP) 12V DC, fan cooling F₁ **watt**

rpm \ °C	-25	-23.3	-20	-15	-10	-6.7	-5	0	5	7.2	10	15
2,500	216	240	290	376	480	560	604	750	918	1002	1114	1340
3,000	252	278	336	438	558	650	702	870	1068	1164	1296	1556
3,500	282	312	376	492	628	732	790	982	1204	1312	1462	1758
4,000	312	346	418	546	698	814	880	1092	1340	1462	1628	1958

Power consumption 12V DC, fan cooling F₁ **watt**

rpm \ °C	-25	-23.3	-20	-15	-10	-6.7	-5	0	5	7.2	10	15
2,500	181	191	212	246	280	304	312	354	392	408	430	466
3,000	216	228	254	296	338	368	384	430	476	496	522	568
3,500	244	260	292	340	394	428	448	504	560	584	616	670
4,000	280	298	336	394	456	498	518	584	650	680	716	782

Current consumption 12V DC, fan cooling F₁ **A**

rpm \ °C	-25	-23.3	-20	-15	-10	-6.7	-5	0	5	7.2	10	15
2,500	15.42	16.30	18.06	20.90	23.86	25.90	26.96	30.12	33.30	34.72	36.50	39.64
3,000	17.98	19.04	21.20	24.64	28.24	30.70	32.00	35.84	39.72	41.42	43.58	47.40
3,500	20.92	22.2	24.78	28.94	33.3	36.26	37.82	42.46	47.14	49.20	51.80	56.42
4,000	23.40	24.92	27.96	32.82	37.94	41.44	43.26	48.70	54.20	56.62	59.68	65.10

COP (EN 12900 Household/CECOMAF) 12V DC, fan cooling F₁ **W/W**

rpm \ °C	-25	-23.3	-20	-15	-10	-6.7	-5	0	5	7.2	10	15
2,500	0.97	1.01	1.10	1.24	1.38	1.48	1.54	1.71	1.89	1.97	2.09	2.30
3,000	0.94	0.98	1.07	1.20	1.33	1.43	1.48	1.63	1.81	1.89	1.99	2.20
3,500	0.93	0.97	1.04	1.16	1.29	1.38	1.43	1.57	1.73	1.81	1.91	2.10
4,000	0.90	0.93	1.01	1.12	1.24	1.32	1.37	1.51	1.66	1.73	1.83	2.01

COP (ASHRAE LBP) 12V DC, fan cooling F₁ **W/W**

rpm \ °C	-25	-23.3	-20	-15	-10	-6.7	-5	0	5	7.2	10	15
2,500	1.20	1.26	1.37	1.54	1.72	1.85	1.92	2.13	2.36	2.47	2.61	2.89
3,000	1.17	1.22	1.33	1.49	1.66	1.78	1.84	2.04	2.26	2.36	2.50	2.76
3,500	1.15	1.20	1.30	1.45	1.61	1.72	1.78	1.96	2.17	2.26	2.39	2.64
4,000	1.11	1.16	1.25	1.39	1.54	1.65	1.70	1.88	2.08	2.17	2.29	2.53

Test conditions	EN 12900/CECOMAF	ASHRAE LBP
Condensing temperature	55°C	54.4°C
Ambient temperature	32°C	32°C
Suction gas temperature	32°C	32°C
Liquid temperature	no subcooling	32°C

Operational errors

Error code	Error type
	Can be read out in the software TOOL4COOL®
6	Thermostat failure (If the NTC thermistor is short-circuit or has no connection, the electronic unit will enter manual mode).
5	Thermal cut-out of electronic unit (If the refrigeration system has been too heavily loaded, or if the ambient temperature is high, the electronic unit will run too hot).
4	Minimum motor speed error (If the refrigeration system is too heavily loaded, the motor cannot maintain minimum speed at approximately 1,850 rpm).
3	Motor start error (The rotor is blocked or the differential pressure in the refrigeration system is too high).
2	Fan over-current cut-out (The fan loads the electronic unit with too high current).
1	Battery protection cut-out (The voltage is outside the cut-out setting).

Accessories for BD350/350GH

Mounting	Code number
Bolt joint for one compressor Ø: 16 mm	118-1917
Bolt joint in quantities Ø: 16 mm	118-1918
Snap-on in quantities Ø: 16 mm	118-1919

Electrical (cables, sensors, etc.)	Code number	
	Single pack	I - Pack
One Wire/LIN gateway communication cable	105N9501	-
Bluetooth® gateway communication cable	105N9502	-
Temperature sensor 470 mm	105N9612	105N9613, 200 pcs.
Temperature sensor 1000 mm	105N9614	105N9615, 100 pcs.
Temperature sensor 1500 mm	105N9616	105N9617, 100 pcs.
Twin comm. cable, 800 mm	-	105N9561, 65 pcs.
Twin comm. cable, 1500 mm	-	105N9555, 65 pcs.
Twin comm. cable, 3000 mm	-	105N9556, 40 pcs.
Display cable, 1500 mm	-	105N9557, 65 pcs.
Display cable, 3000 mm	-	105N9558, 35 pcs.

Not deliverable from Secop

Slow-blow fuse compressor modules	2 x 60A
Slow-blow fuse application module	30A
Main switch	rated to min. 160A

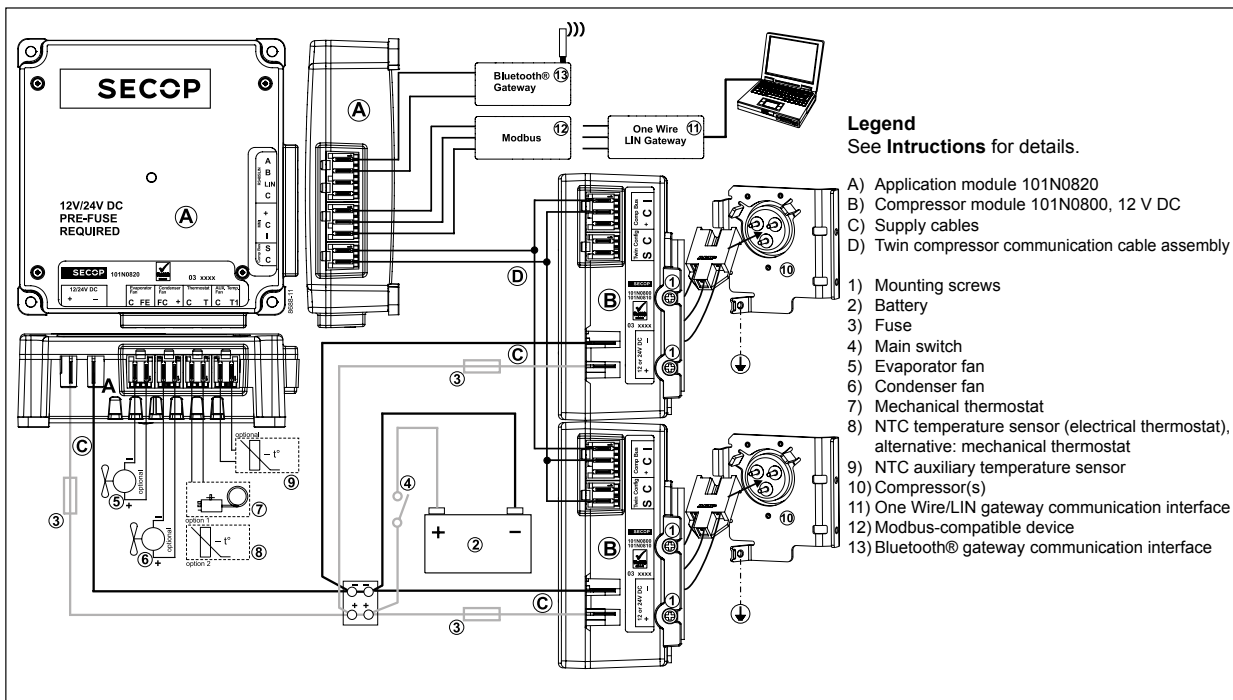



BD350/350GH

Direct Current Twin Compressor

R134a

24V DC - with 101N07xx Series Controllers



General

Code number (without electronic units)	102Z3017
Electronic unit	101N0715, 36 pcs: 101N0714
Approvals	-
Compressors on pallet	50

Application

Application	LBP/MBP/HBP
Evaporating temperature °C	-25 to 15
Voltage range VDC	19 - 31.5
Max. condensing temperature continuous (short) °C	60 (70)
Max. winding temperature continuous (short) °C	125 (135)

Cooling requirements

Application	LBP	MBP	HBP
32°C	F ₁	F ₁	F ₁
38°C	F ₁	F ₁	F ₁
43°C	F ₁	F ₁	F ₁

Remarks on application:
 - evaporator fan max. 60W
 - condenser fan max. 40W
 - starting ability: LST (low starting torque) only

Motor

Motor type	variable speed
Resistance, all 3 windings (25°C) Ω	0.2

Design

Displacement cm ³	2 x 5.08
Oil quantity (type) cm ³	560 (polyolester)
Maximum refrigerant charge g	800
Free gas volume in compressor cm ³	2 x 1690
Weight - Compressor/Electronic unit kg	15.8/2 x 0.27

Battery protection settings

Voltage	Min. value	Default	Max. value
Cut out (0.1 steps) VDC	19.0	21.1	27.0
Cut in diff. (0.1 steps) VDC	0.5	3.9	10.0

Dimensions

Height	mm	A	173
		B	169
		B1	-
		B2	-
Suction connector	location/I.D. mm angle	C	6.2 90°
	material comment		Cu-plated steel Al cap
Process connector	location/I.D. mm angle	D	6.2 31.5°
	material comment		Cu-plated steel Al cap
Discharge connector	location/I.D. mm angle	E	5.0 28°
	material comment		Cu-plated steel Al cap
Connector tolerance	I.D. mm		±0.09, on 5.0 +0.12/+0.20
Remarks			

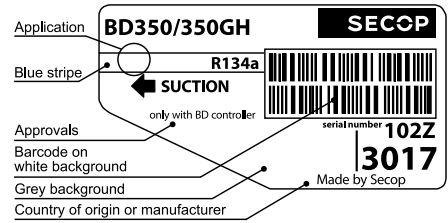

- S = Static cooling normally sufficient
- O = Oil cooling
- F₁ = Fan cooling 1.5 m/s (compressor compartment temperature equal to ambient temperature)
- F₂ = Fan cooling 3.0 m/s necessary
- SG = Suction gas cooling normally sufficient
- = not applicable in this area

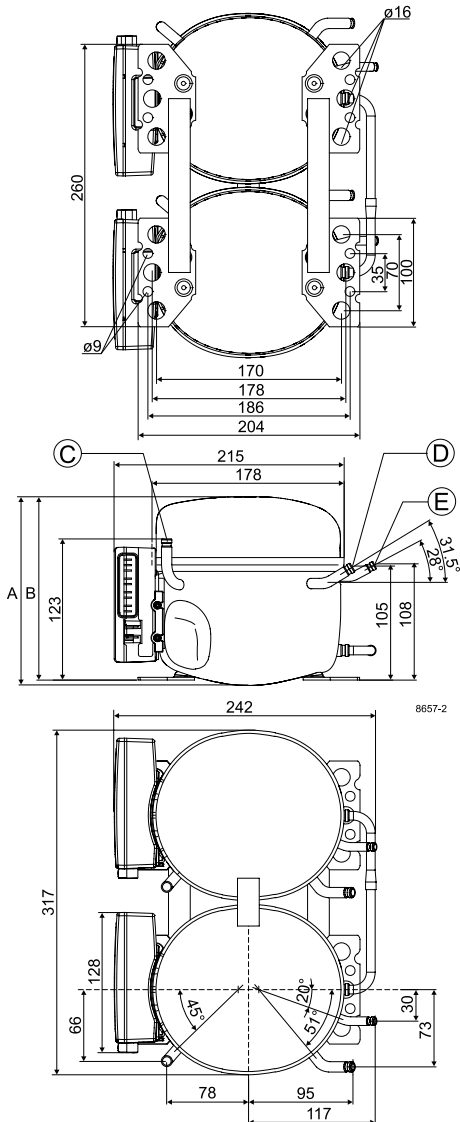

Capacity (EN 12900 Household/CECOMAF) 24V DC, fan cooling F₁ **watt**

rpm \ °C	-25	-23.3	-20	-15	-10	-6.7	-5	0	5	7.2	10	15
2,500	169.4	187.4	226	294	376	438	472	584	716	780	868	1040
3,000	202	224	272	352	450	524	566	702	860	936	1042	1250
3,500	228	252	304	396	508	592	638	792	970	1056	1176	1412
4,000	252	278	338	440	564	658	710	880	1080	1176	1308	1572

Capacity (ASHRAE LBP) 24V DC, fan cooling F₁ **watt**

rpm \ °C	-25	-23.3	-20	-15	-10	-6.7	-5	0	5	7.2	10	15
2,500	210	232	280	364	466	542	584	726	890	970	1078	1296
3,000	252	278	336	438	558	650	702	870	1068	1164	1296	1558
3,500	282	312	376	492	628	732	790	982	1204	1312	1462	1758
4,000	312	346	418	546	698	814	880	1092	1340	1462	1628	1958

Power consumption 24V DC, fan cooling F₁ **watt**

rpm \ °C	-25	-23.3	-20	-15	-10	-6.7	-5	0	5	7.2	10	15
2,500	154.8	163.6	181.6	210	240	260	272	304	336	350	368	400
3,000	191	202	224	258	296	320	334	372	412	430	452	490
3,500	218	230	256	298	342	372	388	434	482	502	528	576
4,000	244	258	288	338	388	424	442	496	552	576	606	660

Current consumption 24V DC, fan cooling F₁ **A**

rpm \ °C	-25	-23.3	-20	-15	-10	-6.7	-5	0	5	7.2	10	15
2,500	6.46	6.82	7.56	8.76	10.02	10.86	11.32	12.64	14.00	14.58	15.34	16.66
3,000	7.96	8.40	9.32	10.78	12.30	13.34	13.90	15.52	17.16	17.88	18.80	20.42
3,500	9.04	9.58	10.68	12.42	14.24	15.50	16.16	18.10	20.06	20.92	22.02	23.96
4,000	10.14	10.76	12.04	14.06	16.20	17.64	18.40	20.68	22.96	23.98	25.26	27.50

COP (EN 12900 Household/CECOMAF) 24V DC, fan cooling F₁ **W/W**

rpm \ °C	-25	-23.3	-20	-15	-10	-6.7	-5	0	5	7.2	10	15
2,500	1.09	1.15	1.25	1.40	1.56	1.68	1.74	1.93	2.13	2.23	2.36	2.60
3,000	1.06	1.11	1.21	1.37	1.53	1.64	1.70	1.88	2.09	2.18	2.31	2.55
3,500	1.05	1.09	1.19	1.33	1.48	1.59	1.65	1.82	2.01	2.10	2.22	2.45
4,000	1.03	1.08	1.17	1.31	1.45	1.55	1.61	1.77	1.96	2.05	2.16	2.38

COP (ASHRAE LBP) 24V DC, fan cooling F₁ **W/W**

rpm \ °C	-25	-23.3	-20	-15	-10	-6.7	-5	0	5	7.2	10	15
2,500	1.36	1.42	1.55	1.74	1.95	2.09	2.17	2.40	2.67	2.79	2.95	3.27
3,000	1.32	1.38	1.51	1.70	1.90	2.04	2.12	2.35	2.61	2.73	2.89	3.20
3,500	1.30	1.36	1.48	1.66	1.85	1.98	2.05	2.27	2.52	2.63	2.79	3.08
4,000	1.28	1.34	1.45	1.62	1.81	1.93	2.00	2.22	2.45	2.56	2.71	2.99

Test conditions

	EN 12900/CECOMAF	ASHRAE LBP
Condensing temperature	55°C	54.4°C
Ambient temperature	32°C	32°C
Suction gas temperature	32°C	32°C
Liquid temperature	no subcooling	32°C

Operational errors

Error code	Error type
	Can be read out in the software TOOL4COOL®
6	Thermostat failure (If the NTC thermistor is short-circuit or has no connection, the electronic unit will enter manual mode).
5	Thermal cut-out of electronic unit (If the refrigeration system has been too heavily loaded, or if the ambient temperature is high, the electronic unit will run too hot).
4	Minimum motor speed error (If the refrigeration system is too heavily loaded, the motor cannot maintain minimum speed at approximately 1,850 rpm).
3	Motor start error (The rotor is blocked or the differential pressure in the refrigeration system is too high).
2	Fan over-current cut-out (The evaporator fan loads the electronic unit with more than 1.8A _{peak} / the condenser fan loads the electronic unit with more than 2.5A _{peak}).
1	Battery protection cut-out (The voltage is outside the cut-out setting).

Accessories for BD350GH

Mounting

	Code number
Bolt joint for one compressor Ø: 16 mm	118-1917
Bolt joint in quantities Ø: 16 mm	118-1918
Snap-on in quantities Ø: 16 mm	118-1919

Electrical (cables, sensors, etc.)

	Code number	
	Single pack	I - Pack
Temperature sensor 470 mm	105N9612	105N9613, 200 pcs.
Temperature sensor 1000 mm	105N9614	105N9615, 100 pcs.
Temperature sensor 1500 mm	105N9616	105N9617, 100 pcs.
One Wire/LIN gateway	105N9501	-
Comm. cable, 1500 mm	-	105N9545, 100 pcs.
Comm. cable, 3000 mm	-	105N9547, 50 pcs.

Not deliverable from Secop
 Slow-blow fuses 2 x 30A
 Main switches rated to min. 2 x 50A

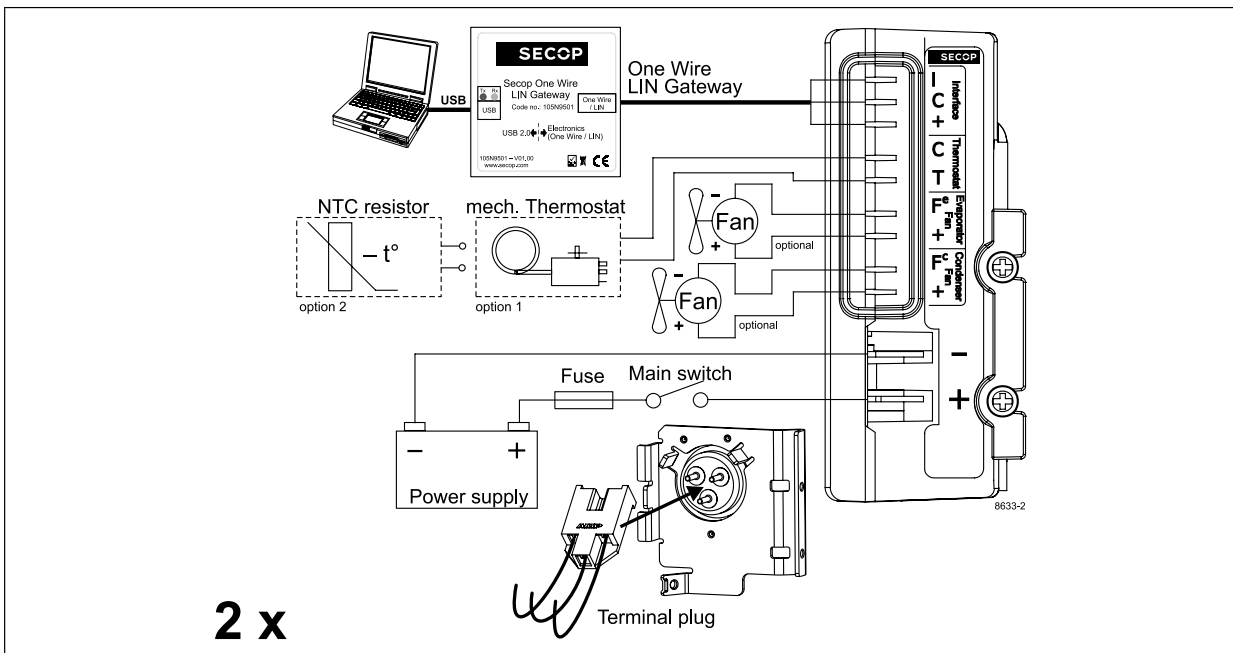

2 x



BD350/350GH

Direct Current Twin Compressor

R134a

12V DC - with 101N08xx Series Controllers

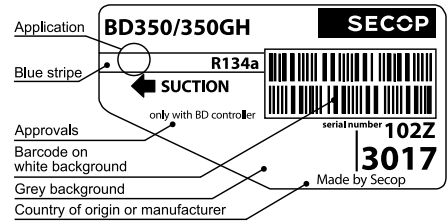

General

Code number (without electronic units)	10223017
Compressor module	101N0810, 30 pcs: 101N0811
Application module	101N0820, 24 pcs: 101N0821
Approvals	-
Compressors on pallet	50

Application

Application	LBP/MBP/HBP
Evaporating temperature °C	-25 to 15
Voltage range VDC	19 - 31.5
Max. condensing temperature continuous (short) °C	60 (70)
Max. winding temperature continuous (short) °C	125 (135)

Cooling requirements

Application	LBP	MBP	HBP
32°C	F ₁	F ₁	F ₁
38°C	F ₁	F ₁	F ₁
43°C	F ₁	F ₁	F ₁

Remarks on application:
 - evaporator fan max. 200W
 - condenser fan max. 100W
 - starting ability: LST (low starting torque) only

Motor

Motor type	variable speed
Resistance, all 3 windings (25°C) Ω	0.1

Design

Displacement cm ³	2 x 5.08
Oil quantity (type) cm ³	560 (polyolester)
Maximum refrigerant charge g	800
Free gas volume in compressor cm ³	2 x 1690
Weight - Compressor/Electronic unit kg	15.8/2 x 0.25, 1 x 0.28

Battery protection settings

Voltage	Min. value	Default	Max. value
Cut out (0.1 steps) VDC	19.0	21.1	27.0
Cut in diff. (0.1 steps) VDC	0.5	3.9	10.0

Dimensions

Height mm	A	173
	B	169
	B1	-
	B2	-
Suction connector location/I.D. mm angle	C	6.2 90°
material comment		Cu-plated steel Al cap
Process connector location/I.D. mm angle	D	6.2 31.5°
material comment		Cu-plated steel Al cap
Discharge connector location/I.D. mm angle	E	5.0 28°
material comment		Cu-plated steel Al cap
Connector tolerance I.D. mm		±0.09, on 5.0 +0.12/+0.20
Remarks		

- S = Static cooling normally sufficient
- O = Oil cooling
- F₁ = Fan cooling 1.5 m/s (compressor compartment temperature equal to ambient temperature)
- F₂ = Fan cooling 3.0 m/s necessary
- SG = Suction gas cooling normally sufficient
- = not applicable in this area

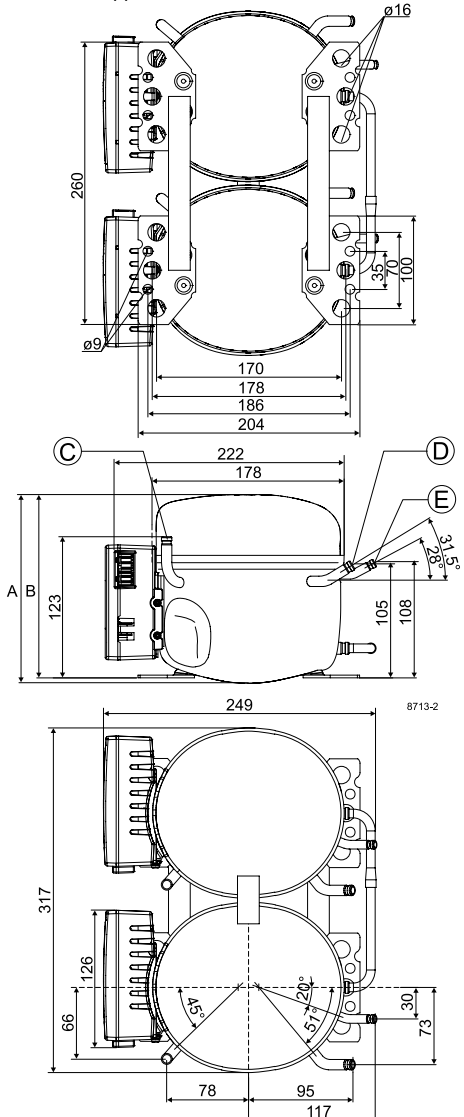

Capacity (EN 12900 Household/CECOMAF) 24V DC, fan cooling F₁ watt

rpm \ °C	-25	-23.3	-20	-15	-10	-6.7	-5	0	5	7.2	10	15
2,500	169.4	187.4	226	294	376	438	472	584	716	780	868	1040
3,000	202	224	272	352	450	524	566	702	860	936	1042	1250
3,500	228	252	304	396	508	592	638	792	970	1056	1176	1412
4,000	252	278	338	440	564	658	710	880	1080	1176	1308	1572

Capacity (ASHRAE LBP) 24V DC, fan cooling F₁ watt

rpm \ °C	-25	-23.3	-20	-15	-10	-6.7	-5	0	5	7.2	10	15
2,500	210	232	280	364	466	542	584	726	890	970	1078	1296
3,000	252	278	336	438	558	650	702	870	1068	1164	1296	1558
3,500	282	312	376	492	628	732	790	982	1204	1312	1462	1758
4,000	312	346	418	546	698	814	880	1092	1340	1462	1628	1958

Power consumption 24V DC, fan cooling F₁ watt

rpm \ °C	-25	-23.3	-20	-15	-10	-6.7	-5	0	5	7.2	10	15
2,500	154.8	163.6	181.6	210	240	260	272	304	336	350	368	400
3,000	191	202	224	258	296	320	334	372	412	430	452	490
3,500	218	230	256	298	342	372	388	434	482	502	528	576
4,000	244	258	288	338	388	424	442	496	552	576	606	660

Current consumption 24V DC, fan cooling F₁ A

rpm \ °C	-25	-23.3	-20	-15	-10	-6.7	-5	0	5	7.2	10	15
2,500	6.46	6.82	7.56	8.76	10.02	10.86	11.32	12.64	14.00	14.58	15.34	16.66
3,000	7.96	8.40	9.32	10.78	12.30	13.34	13.90	15.52	17.16	17.88	18.80	20.42
3,500	9.04	9.58	10.68	12.42	14.24	15.50	16.16	18.10	20.06	20.92	22.02	23.96
4,000	10.14	10.76	12.04	14.06	16.20	17.64	18.40	20.68	22.96	23.98	25.26	27.50

COP (EN 12900 Household/CECOMAF) 24V DC, fan cooling F₁ W/W

rpm \ °C	-25	-23.3	-20	-15	-10	-6.7	-5	0	5	7.2	10	15
2,500	1.09	1.15	1.25	1.40	1.56	1.68	1.74	1.93	2.13	2.23	2.36	2.60
3,000	1.06	1.11	1.21	1.37	1.53	1.64	1.70	1.88	2.09	2.18	2.31	2.55
3,500	1.05	1.09	1.19	1.33	1.48	1.59	1.65	1.82	2.01	2.10	2.22	2.45
4,000	1.03	1.08	1.17	1.31	1.45	1.55	1.61	1.77	1.96	2.05	2.16	2.38

COP (ASHRAE LBP) 24V DC, fan cooling F₁ W/W

rpm \ °C	-25	-23.3	-20	-15	-10	-6.7	-5	0	5	7.2	10	15
2,500	1.36	1.42	1.55	1.74	1.95	2.09	2.17	2.40	2.67	2.79	2.95	3.27
3,000	1.32	1.38	1.51	1.70	1.90	2.04	2.12	2.35	2.61	2.73	2.89	3.20
3,500	1.30	1.36	1.48	1.66	1.85	1.98	2.05	2.27	2.52	2.63	2.79	3.08
4,000	1.28	1.34	1.45	1.62	1.81	1.93	2.00	2.22	2.45	2.56	2.71	2.99

Test conditions	EN 12900/CECOMAF	ASHRAE LBP
Condensing temperature	55°C	54.4°C
Ambient temperature	32°C	32°C
Suction gas temperature	32°C	32°C
Liquid temperature	no subcooling	32°C

Operational errors

Error code	Error type
	Can be read out in the software TOOL4COOL®
6	Thermostat failure (If the NTC thermistor is short-circuit or has no connection, the electronic unit will enter manual mode).
5	Thermal cut-out of electronic unit (If the refrigeration system has been too heavily loaded, or if the ambient temperature is high, the electronic unit will run too hot).
4	Minimum motor speed error (If the refrigeration system is too heavily loaded, the motor cannot maintain minimum speed at approximately 1,850 rpm).
3	Motor start error (The rotor is blocked or the differential pressure in the refrigeration system is too high).
2	Fan over-current cut-out (The fan loads the electronic unit with too high current).
1	Battery protection cut-out (The voltage is outside the cut-out setting).

Accessories for BD350/350GH

Mounting	Code number
Bolt joint for one compressor Ø: 16 mm	118-1917
Bolt joint in quantities Ø: 16 mm	118-1918
Snap-on in quantities Ø: 16 mm	118-1919

Electrical (cables, sensors, etc.)	Code number	
	Single pack	I - Pack
One Wire/LIN gateway communication cable	105N9501	-
Bluetooth® gateway communication cable	105N9502	-
Temperature sensor 470 mm	105N9612	105N9613, 200 pcs.
Temperature sensor 1000 mm	105N9614	105N9615, 100 pcs.
Temperature sensor 1500 mm	105N9616	105N9617, 100 pcs.
Twin comm. cable, 800 mm	-	105N9561, 65 pcs.
Twin comm. cable, 1500 mm	-	105N9555, 65 pcs.
Twin comm. cable, 3000 mm	-	105N9556, 40 pcs.
Display cable, 1500 mm	-	105N9557, 65 pcs.
Display cable, 3000 mm	-	105N9558, 35 pcs.

Not deliverable from Secop

Slow-blow fuse compressor modules	2 x 60A
Slow-blow fuse application module	30A
Main switch	rated to min. 160A

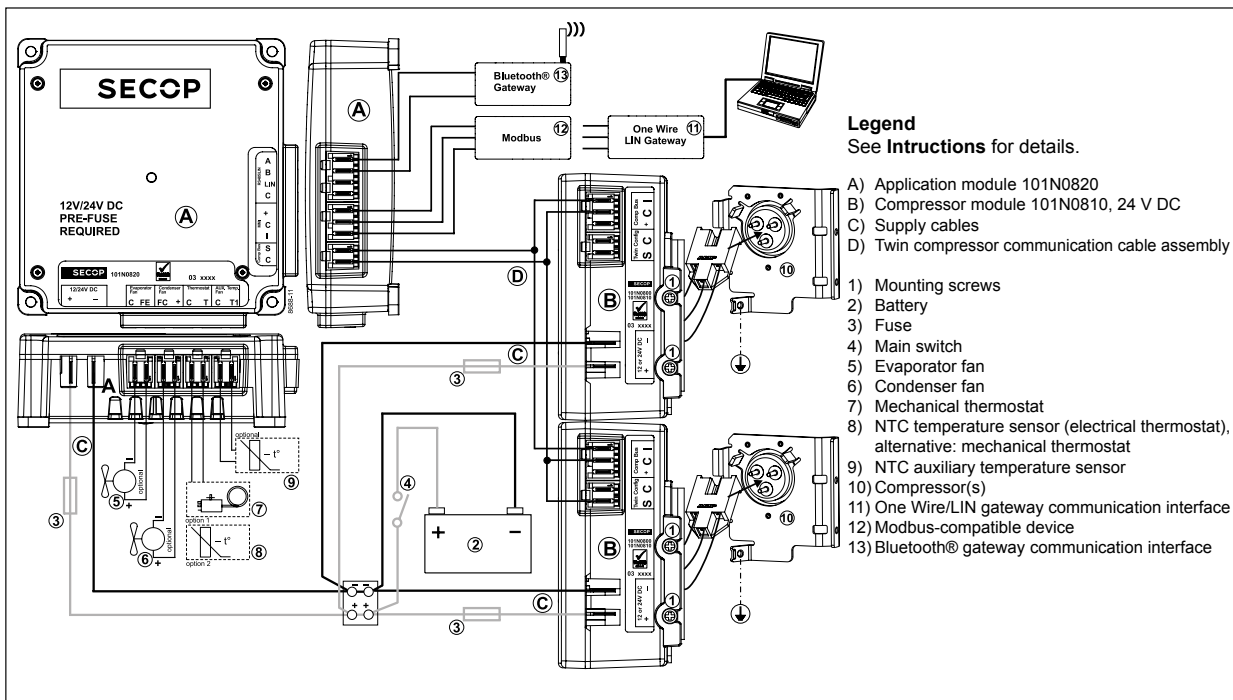



BD35K Direct Current Compressor for Solar Applications R600a, 10-45V DC

General

Code number (without electronic units)	101Z0211
Electronic unit 10-30V DC - Solar	101N0400, 30 pcs: 101N0401
Electronic unit 20-45V DC - Solar	101N0410, 30 pcs: 101N0411
Electronic unit 12-24V DC - Standard	101N0210, 30 pcs: 101N0211
Electronic unit 12-24V DC - EMI (with metal shielding)	101N0220, 30 pcs: 101N0221
Approved compressor - electronic unit combinations	refer to <i>Instructions</i> for 101N0xxx
Additional approvals	e4, C-Tick
Compressors on pallet	150

Application

Application		LBP/MBP/(HBP)
Evaporating temperature °C		-30 to 0 (10)
Voltage range VDC		10 - 30 / 20 - 45
Max. condensing temperature continuous (short) °C		60 (70)
Max. winding temperature continuous (short) °C		125 (135)

Cooling requirements

Application	LBP	MBP	HBP
32°C	S	S	S
38°C	S	S	S
43°C	S	S	S

Remarks on application: - Fan cooling F1 depending on application and speed.
- **for stationary use only**

Motor

Motor type		variable speed
Resistance, all 3 windings (25°C) Ω		1.8

Design

Displacement cm ³		3.00
Oil quantity (type) cm ³		150 (polyolester)
Maximum refrigerant charge g		120
Free gas volume in compressor cm ³		870
Weight - Compressor/Electronic unit kg		4.3 / 0.26 (Solar)

Dimensions

Height mm	A	137
	B	135
	B1	128
	B2	73
Suction connector location/I.D. mm angle	C	6.2 40°
material comment		Cu-plated steel Al cap
Process connector location/I.D. mm angle	D	6.2 45°
material comment		Cu-plated steel Al cap
Discharge connector location/I.D. mm angle	E	5.0 21°
material comment		Cu-plated steel Al cap
Connector tolerance I.D. mm		±0.09, on 5.0 +0.12/+0.20
Remarks:		

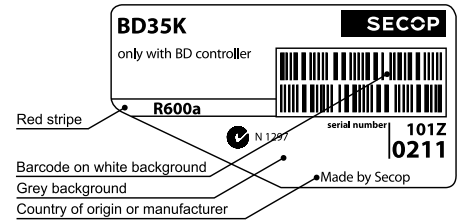

- S = Static cooling normally sufficient
- O = Oil cooling
- F₁ = Fan cooling 1.5 m/s (compressor compartment temperature equal to ambient temperature)
- F₂ = Fan cooling 3.0 m/s necessary
- SG = Suction gas cooling normally sufficient
- = not applicable in this area

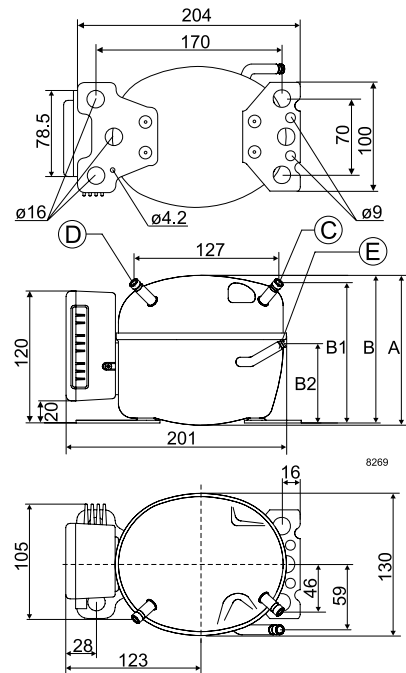



Capacity (EN 12900 Household/CECOMAF) 12V DC, static cooling **watt**

rpm \ °C	-30	-25	-23.3	-20	-15	-10	-5	0	5	7.2	10	15
2,000	13.2	21.0	23.8	29.7	39.6	51.0	64.0	79.1	96.3	105	116	
2,500	16.8	25.5	28.8	35.6	47.5	61.3	77.5	96.2	118	128		
3,000	20.7	30.5	34.3	42.3	56.3	72.9	92.4	115				
3,500	24.9	36.0	40.2	49.3	65.1	83.8	106					

Capacity (ASHRAE LBP) 12V DC, static cooling **watt**

rpm \ °C	-30	-25	-23.3	-20	-15	-10	-5	0	5	7.2	10	15
2,000	16.0	25.5	29.0	36.1	48.2	62.1	78.0	96.4	118	128	142	
2,500	20.4	31.0	35.0	43.4	57.8	74.7	94.4	117	144	157		
3,000	25.2	37.1	41.7	51.4	68.5	88.7	113	140				
3,500	30.3	43.8	49.0	59.9	79.2	102	129					

Power consumption 12V DC, static cooling **watt**

rpm \ °C	-30	-25	-23.3	-20	-15	-10	-5	0	5	7.2	10	15
2,000	18.5	22.5	23.9	26.4	30.3	34.2	38.0	41.8	45.7	47.4	49.6	
2,500	23.8	28.5	30.0	32.9	37.2	41.5	45.8	50.2	54.9	57.1		
3,000	29.5	35.9	38.0	41.8	47.4	52.9	58.6	64.6				
3,500	35.1	42.7	45.2	49.7	56.4	63.0	69.7					

Current consumption (for 24V applications the following must be halved) **A**

rpm \ °C	-30	-25	-23.3	-20	-15	-10	-5	0	5	7.2	10	15
2,000	1.54	1.88	1.99	2.20	2.53	2.85	3.17	3.48	3.81	3.95	4.13	
2,500	1.98	2.37	2.50	2.75	3.10	3.46	3.82	4.19	4.58	4.76		
3,000	2.46	2.99	3.16	3.48	3.95	4.41	4.88	5.38				
3,500	2.93	3.56	3.76	4.15	4.70	5.25	5.81					

COP (EN 12900 Household/CECOMAF) **W/W**

rpm \ °C	-30	-25	-23.3	-20	-15	-10	-5	0	5	7.2	10	15
2,000	0.71	0.93	1.00	1.12	1.31	1.49	1.69	1.89	2.11	2.21	2.34	
2,500	0.71	0.90	0.96	1.08	1.28	1.48	1.69	1.92	2.15	2.25		
3,000	0.70	0.85	0.90	1.01	1.19	1.38	1.58	1.78				
3,500	0.71	0.84	0.89	0.99	1.15	1.33	1.52					

COP (ASHRAE LBP) 12V DC, static cooling **W/W**

rpm \ °C	-30	-25	-23.3	-20	-15	-10	-5	0	5	7.2	10	15
2,000	0.87	1.13	1.21	1.37	1.59	1.82	2.05	2.31	2.57	2.70	2.86	
2,500	0.86	1.09	1.17	1.32	1.55	1.80	2.06	2.34	2.62	2.74		
3,000	0.85	1.03	1.10	1.23	1.44	1.68	1.92	2.17				
3,500	0.86	1.03	1.08	1.21	1.40	1.62	1.85					

Test conditions	EN 12900/CECOMAF	ASHRAE LBP
Condensing temperature	55°C	54.4°C
Ambient temperature	32°C	32°C
Suction gas temperature	32°C	32°C
Liquid temperature	no subcooling	32°C

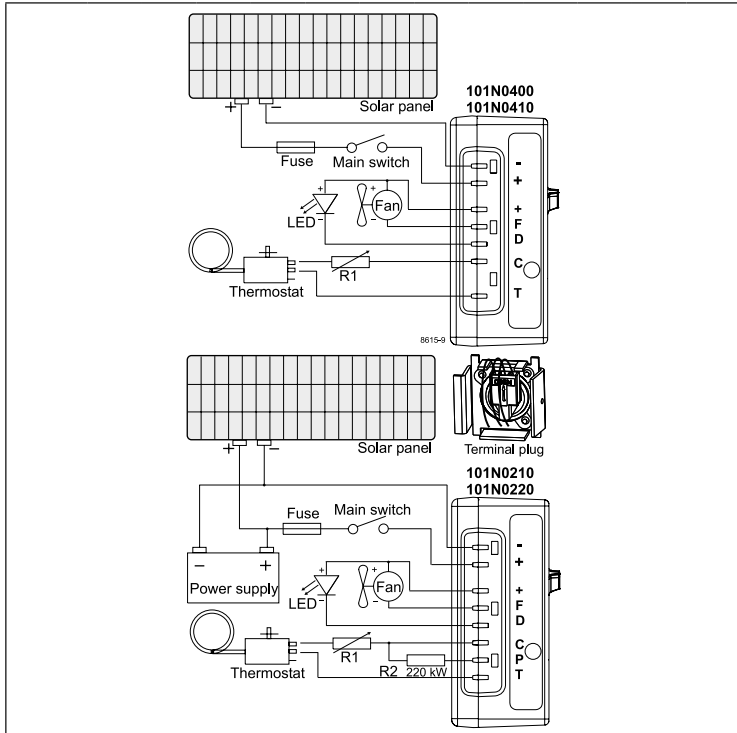

Operational errors shown by LED (optional)

Error code	Error type
5	Thermal cut-out of electronic unit (If the refrigeration system has been too heavily loaded, or if the ambient temperature is high, the electronic unit will run too hot).
4	Minimum motor speed error (If the refrigeration system is too heavily loaded, the motor cannot maintain minimum speed at approximately 1,850 rpm).
3	Motor start error (The rotor is blocked or the differential pressure in the refrigeration system is too high (>5 bar)).
2	Fan over-current cut-out (The fan loads the electronic unit with more than 1A _{peak}).
1	Battery protection cut-out (The voltage is outside the cut-out setting).

Compressor speed

Electronit unit	Resistor (R1) [Ω] calculated values	Motor speed [rpm]	Control circuit current [mA]
101N0210	0	2,000	5
	277	2,500	4
101N0220	692	3,000	3
	1523	3,500	2
101N0400	0	AEO	6
	173	2,000	5
101N0410 with AEO	450	2,500	4
	865	3,000	3
	1696	3,500	2

In AEO (Adaptive Energy Optimizing) speed mode the BD compressor will always adapt its speed to the actual cooling demand.

Wire Dimensions DC

Cross section [mm²]	Size AWG [Gauge]	Max. length* 12V operation		Max. length* 24V operation	
		[m]	[ft.]	[m]	[ft.]
2.5	12	2.5	8	5	16
4	12	4	13	8	26
6	10	6	20	12	39
10	8	10	33	20	66

*Length between battery and an electronic unit

Accessories for BD35K

Accessories for BD35K	Code number
Bolt joint for one comp. Ø:16 mm	118-1917
Bolt joint in quantities Ø:16 mm	118-1918
Snap-on in quantities Ø:16 mm	118-1919
Remote kit (without cable)	105N9210

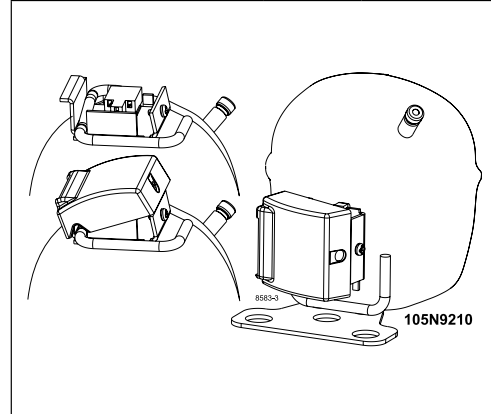

Automobile fuse DIN 7258	12V: 15A 24V: 7.5 A	Not deliverable from Secop
Main switch	min. 20A	



BD80CN Direct Current Compressor R290 12-24V DC

General

Code number (without electronic units)	101Z0403
Electronic unit 12-24V DC - High Start Performance	101N0230, 30 pcs: 101N0231
Electronic unit 12-24V DC - AEO & High Start	101N0330, 30 pcs: 101N0331
Approved compressor - electronic unit combinations	refer to <i>Instructions</i> for 101N0xxx
Additional approvals	e4, C-Tick
Compressors on pallet	150

Application

Application	LBP
Evaporating temperature °C	-40 to -10
Voltagege VDC	9.6 - 17 / 21.3 - 31.5
Max. condensing temperature continuous (short) °C	55 (65)
Max. winding temperature continuous (short) °C	125 (135)

Cooling requirements

Application	LBP	MBP	HBP
32°C	S	-	-
38°C	S	-	-
43°C	S	-	-
Remarks on application: for stationary use only			

Motor

Motor type	variable speed
Resistance, all 3 windings (25°C) Ω	1.8

Design

Displacement cm ³	2.00
Oil quantity (type) cm ³	150 (polyolester)
Maximum refrigerant charge g	120
Free gas volume in compressor cm ³	870
Weight - Compressor/Electronic unit kg	4.3 / 0.28 (High Start)

Standard battery protection settings (refer to 101N0xxx *Instructions* for optional settings)

Voltage	12V	24V
Cut out VDC	10.4	22.8
Cut in VDC	11.7	24.2

Dimensions

Height	mm	A	137
		B	135
		B1	128
		B2	73
Suction connector	location/I.D. mm angle	C	6.2 40°
	material comment		Cu-plated steel Al cap
Process connector	location/I.D. mm angle	D	6.2 45°
	material comment		Cu-plated steel Al cap
Discharge connector	location/I.D. mm angle	E	5.0 21°
	material comment		Cu-plated steel Al cap
Connector tolerance	I.D. mm		±0.09, on 5.0 +0.12/+0.20
Remarks			

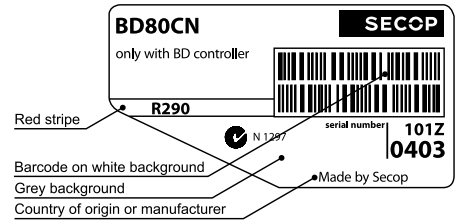

- S = Static cooling normally sufficient
- O = Oil cooling
- F₁ = Fan cooling 1.5 m/s (compressor compartment temperature equal to ambient temperature)
- F₂ = Fan cooling 3.0 m/s necessary
- SG = Suction gas cooling normally sufficient
- = not applicable in this area

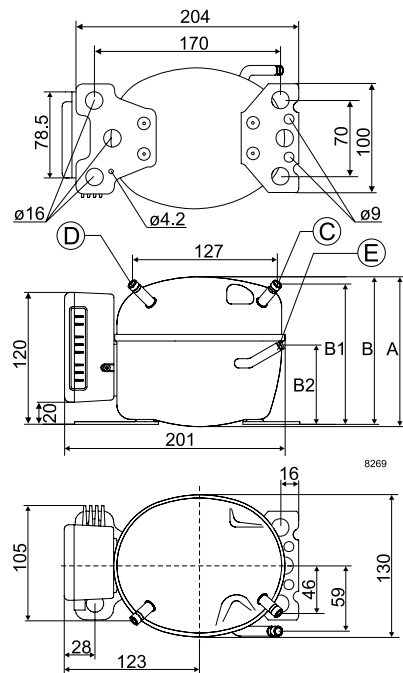

Capacity (EN 12900 Household/CECOMAF*) 12V DC, static cooling **watt**

rpm \ °C	-40	-35	-30	-25	-23.3	-20	-15	-10	-5	0	5	7.2
2,500	19.8	29.3	41.0	55.0	60.4	71.8	92	115				
3,000	27.7	39.7	54.1	71.4	78.0	92	116	144				
3,500	31.3	45.3	62.1	82.0	90	105	133	164				

Capacity (ASHRAE LBP*) 12V DC, static cooling **watt**

rpm \ °C	-40	-35	-30	-25	-23.3	-20	-15	-10	-5	0	5	7.2
2,500	32.8	37.3	42.8	61.4	67.4	80.2	102	128				
3,000	30.9	44.2	60.4	79.7	87	103	130	161				
3,500	34.9	50.5	69.2	91	100	118	148	184				

Power consumption 12V DC, static cooling **watt**

rpm \ °C	-40	-35	-30	-25	-23.3	-20	-15	-10	-5	0	5	7.2
2,500	32.8	37.3	42.8	49.0	51.2	55.6	62.0	68.1				
3,000	40.4	46.7	54.0	61.8	64.6	69.9	77.8	85.2				
3,500	46.9	54.8	63.2	72.0	75.0	80.8	89.3	97				

Current consumption (for 24V applications the following must be halved) **A**

rpm \ °C	-40	-35	-30	-25	-23.3	-20	-15	-10	-5	0	5	7.2
2,500	2.97	3.32	3.74	4.21	4.38	4.70	5.19	5.65				
3,000	3.37	3.89	4.50	5.15	5.38	5.82	6.48	7.10				
3,500	3.50	4.08	4.71	5.35	5.57	6.00	6.63	7.23				

COP (EN 12900 Household/CECOMAF*) 12V DC, static cooling **W/W**

rpm \ °C	-40	-35	-30	-25	-23.3	-20	-15	-10	-5	0	5	7.2
2,500	0.60	0.79	0.96	1.12	1.18	1.29	1.48	1.69				
3,000	0.69	0.85	1.00	1.15	1.21	1.32	1.49	1.69				
3,500	0.67	0.83	0.98	1.14	1.19	1.31	1.49	1.69				

COP (ASHRAE LBP*) 12V DC, static cooling **W/W**

rpm \ °C	-40	-35	-30	-25	-23.3	-20	-15	-10	-5	0	5	7.2
2,500	0.67	0.88	1.07	1.25	1.32	1.44	1.65	1.88				
3,000	0.77	0.95	1.12	1.29	1.35	1.47	1.66	1.89				
3,500	0.74	0.92	1.10	1.27	1.33	1.46	1.66	1.89				

Test conditions	EN 12900/CECOMAF*	ASHRAE LBP*
Condensing temperature	45°C	45°C
Ambient temperature	32°C	32°C
Suction gas temperature	32°C	32°C
Liquid temperature	no subcooling	32°C

Operational errors shown by LED (optional)

Error code	Error type
5	Thermal cut-out of electronic unit (If the refrigeration system has been too heavily loaded, or if the ambient temperature is high, the electronic unit will run too hot).
4	Minimum motor speed error (If the refrigeration system is too heavily loaded, the motor cannot maintain minimum speed at approximately 1,850 rpm).
3	Motor start error (The rotor is blocked or the differential pressure in the refrigeration system is too high (>5 bar)).
2	Fan over-current cut-out (The fan loads the electronic unit with more than 1A _{peak}).
1	Battery protection cut-out (The voltage is outside the cut-out setting).

Compressor speed

Electronit unit	Resistor (R1) [Ω] calculated values	Motor speed [rpm]	Control circuit current [mA]
101N0230	0	2,000	5
	277	2,500	4
	692	3,000	3
101N0330 with AEO	1523	3,500	2
	0	AEO	6
	173	2,000	5
	450	2,500	4
	865	3,000	3
	1696	3,500	2

In AEO (Adaptive Energy Optimizing) speed mode the BD compressor will always adapt its speed to the actual cooling demand.

Wire Dimensions DC

Cross section [mm ²]	Size AWG [Gauge]	Max. length* 12V operation		Max. length* 24V operation	
		[m]	[ft.]	[m]	[ft.]
2.5	12	2.5	8	5	16
4	12	4	13	8	26
6	10	6	20	12	39
10	8	10	33	20	66

*Length between battery and electronic unit

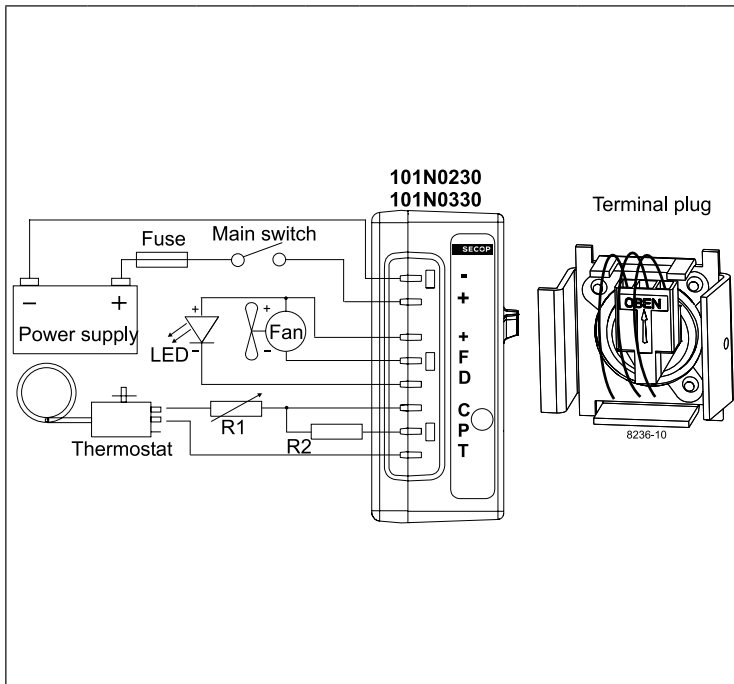

Accessories for BD80CN

Accessories for BD80CN	Code number
Bolt joint for one comp. Ø:16 mm	118-1917
Bolt joint in quantities Ø:16 mm	118-1918
Snap-on in quantities Ø:16 mm	118-1919
Remote kit (without cable)	105N9210

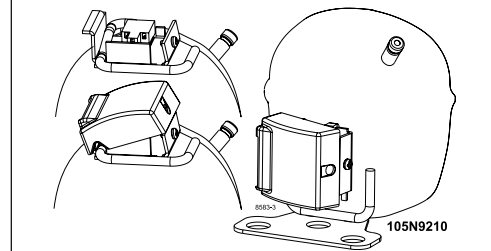

Standard automobile fuse DIN 7258	12V: 30A 24V: 15A	Not deliverable from Secop
Main switch	min. 30A	



BD100CN Direct Current Compressor R290 12-24V DC

General

Code number (without electronic units)	101Z0401
Electronic unit - High Speed	101N0290, 28 pcs: 101N0291
Approved compressor - electronic unit combinations	refer to <i>Instructions</i> for 101N0290
Additional approvals	e4, C-Tick
Compressors on pallet	150

Application

Application	LBP
Evaporating temperature °C	-40 to -10
Voltage/max. voltage VDC	9.6 - 17 / 21.3 - 31.5
Max. condensing temperature continuous (short) °C	55 (65)
Max. winding temperature continuous (short) °C	125 (135)

Cooling requirements

Application	LBP	MBP	HBP
32°C	S	-	-
38°C	S	-	-
43°C	S	-	-
Remarks on application: for stationary use only			

Motor

Motor type	Variable speed
Resistance, all 3 windings (25°C) Ω	1.8

Design

Displacement cm ³	2.00
Oil quantity (type) cm ³	150 (polyolester)
Maximum refrigerant charge g	120
Free gas volume in compressor cm ³	870
Weight - Compressor/Electronic unit kg	4.3/0.32

Standard battery protection settings (refer to 101N0290 Instructions for optional settings)

Voltage	12V	24V
Cut out VDC	10.4	22.8
Cut in VDC	11.7	24.2

Dimensions

Height	mm	A	137
		B	135
		B1	128
		B2	73
Suction connector	location/I.D. mm angle	C	6.2 40°
	material comment		Cu-plated steel Al cap
Process connector	location/I.D. mm angle	D	6.2 45°
	material comment		Cu-plated steel Al cap
Discharge connector	location/I.D. mm angle	E	5.0 21°
	material comment		Cu-plated steel Al cap
Connector tolerance	I.D. mm		±0.09, on 5.0 +0.12/+0.20
Remarks			

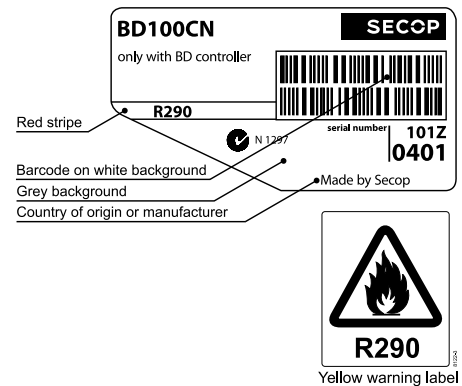

- S = Static cooling normally sufficient
- O = Oil cooling
- F₁ = Fan cooling 1.5 m/s
(compressor compartment temperature equal to ambient temperature)
- F₂ = Fan cooling 3.0 m/s necessary
- SG = Suction gas cooling normally sufficient
- = not applicable in this area

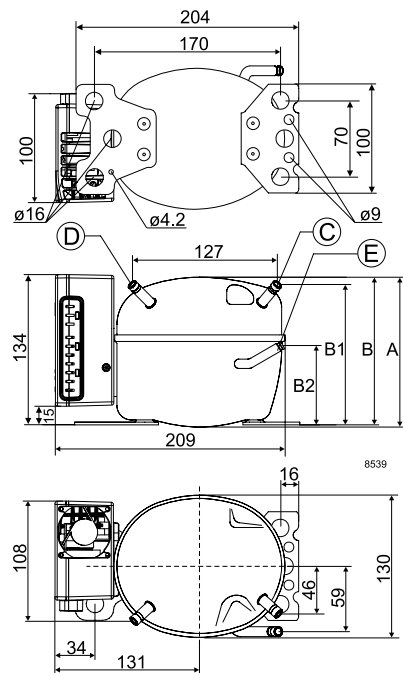

Capacity (EN 12900 Household/CECOMAF) 12V DC, static cooling **watt**

rpm \ °C	-40	-35	-30	-25	-23.3	-20	-15	-10	-5	0	5	7.2
2,500	30.6	40.2	51.9	66.0	71.4	82.9	103	126				
3,100	36.0	49.0	64.6	83.0	90.0	105	130	160				
3,800	40.5	56.6	75.6	98.0	106	124	154	189				
4,400	44.6	62.4	83.4	108	117	137	170	209				

Capacity (ASHRAE LBP) 12V DC, static cooling **watt**

rpm \ °C	-40	-35	-30	-25	-23.3	-20	-15	-10	-5	0	5	7.2
2,500	34.1	44.8	57.9	73.6	79.7	92.5	115	141				
3,100	40.1	54.6	72.0	92.6	100	117	145	178				
3,800	45.1	63.1	84.3	109	119	138	172	211				
4,400	49.7	69.6	93.0	121	131	153	190	233				

Power consumption 12V DC, static cooling **watt**

rpm \ °C	-40	-35	-30	-25	-23.3	-20	-15	-10	-5	0	5	7.2
2,500	35.7	39.8	44.8	50.5	52.5	56.4	62.3	67.8				
3,100	41.9	48.9	56.3	64.0	66.7	71.8	79.4	86.5				
3,800	48.7	58.6	68.6	78.5	81.8	88.1	97.5	106				
4,400	57.4	69.1	80.8	92.5	96.4	104	115	125				

Current consumption (for 24V applications the following must be halved) **A**

rpm \ °C	-40	-35	-30	-25	-23.3	-20	-15	-10	-5	0	5	7.2
2,500	2.97	3.32	3.74	4.21	4.38	4.70	5.19	5.65				
3,100	3.49	4.07	4.69	5.34	5.56	5.98	6.61	7.20				
3,800	4.06	4.88	5.71	6.54	6.82	7.35	8.12	8.86				
4,400	4.78	5.76	6.74	7.71	8.04	8.66	9.58	10.44				

COP (EN 12900 Household/CECOMAF) 12V DC, static cooling **W/W**

rpm \ °C	-40	-35	-30	-25	-23.3	-20	-15	-10	-5	0	5	7.2
2,500	0.86	1.01	1.16	1.31	1.36	1.47	1.65	1.86				
3,100	0.86	1.00	1.15	1.30	1.35	1.46	1.64	1.85				
3,800	0.83	0.97	1.10	1.25	1.30	1.41	1.58	1.78				
4,400	0.78	0.90	1.03	1.17	1.22	1.32	1.48	1.66				

COP (ASHRAE LBP) 12V DC, static cooling **W/W**

rpm \ °C	-40	-35	-30	-25	-23.3	-20	-15	-10	-5	0	5	7.2
2,500	0.96	1.13	1.29	1.46	1.52	1.64	1.84	2.08				
3,100	0.96	1.12	1.28	1.45	1.51	1.63	1.83	2.06				
3,800	0.93	1.08	1.23	1.39	1.45	1.57	1.77	1.99				
4,400	0.87	1.01	1.15	1.30	1.36	1.47	1.65	1.86				

Test conditions	EN 12900/CECOMAF*	ASHRAE LBP*
Condensing temperature	45°C	45°C
Ambient temperature	32°C	32°C
Suction gas temperature	32°C	32°C
Liquid temperature	no subcooling	32°C

Operational errors errors shown by LED (optional)

Error code	Error type
5	Thermal cut-out of electronic unit (If the refrigeration system has been too heavily loaded, or if the ambient temperature is high, the electronic unit will run too hot).
4	Minimum motor speed error (If the refrigeration system is too heavily loaded, the motor cannot maintain minimum speed at approximately 2,450 rpm).
3	Motor start error (The rotor is blocked or the differential pres-sure in the refrigeration system is too high (>5 bar)).
2	Fan over-current cut-out (The fan loads the electronic unit with more than 1A _{peak}).
1	Battery protection cut-out (The voltage is outside the cut-out setting).

Compressor speed

Electronit unit	Resistor (R1) [Ω] calculated values	Motor speed [rpm]	Control circuit current [mA]
101N0290 with AEO	0	AEO	6
	203	2,500	5
	451	3,100	4
	867	3,800	3
	1700	4,400	2

In AEO (Adaptive Energy Optimizing) speed mode the BD compressor will always adapt its speed to the actual cooling demand.

Wire Dimensions DC

Cross section [mm²]	Size AWG [Gauge]	Max. length* 12V operation		Max. length* 24V operation	
		[m]	[ft.]	[m]	[ft.]
6	10	2.5	8	5	16

*Length between battery and electronic unit

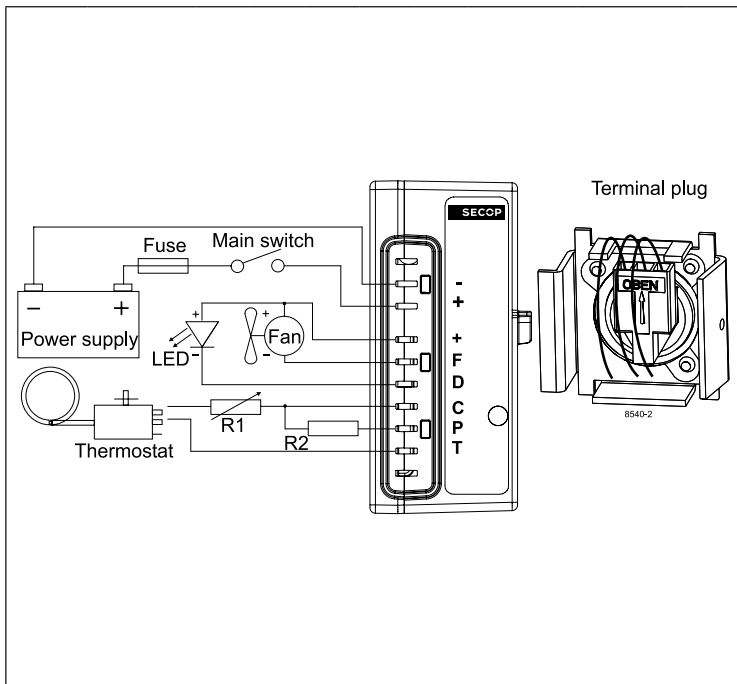

Accessories for BD100CN	Code number
Bolt joint for one compressor Ø:16 mm	118-1917
Bolt joint in quantities Ø:16 mm	118-1918
Snap-on in quantities Ø:16 mm	118-1919
Remote kit (without cable)	105N9210

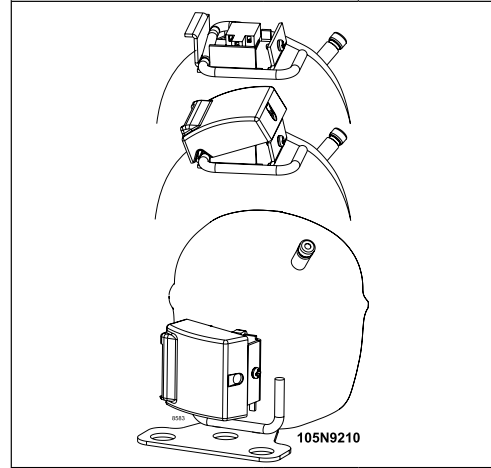

Standard automobile fuse DIN 7258	12V: 30A 24V: 15A	Not deliverable from Secop
Main switch	min. 30A	



BD220CL

Direct Current Compressor

R404A/R507

12V DC - with 101N08xx Series Controllers



General

Code number (without electronic units)	102Z3020
Compressor module	101N0800, 30 pcs: 101N0801
Application module	101N0820, 24 pcs: 101N0821
Alternative (one interface only): Electronic Unit (no fan connection/no twin option)	101N0830, 30 pcs: 101N0831
Approvals	-
Compressors on pallet	125

Application

Application	LBP
Evaporating temperature °C	-45 to -5
Voltage range VDC	9.6 - 17
Max. condensing temperature continuous (short) °C	50 (60)
Max. winding temperature continuous (short) °C	125 (135)

Cooling requirements

Application	LBP	MBP	HBP
32°C	F ₁	-	-
38°C	F ₁	-	-
43°C	F ₁	-	-

Remarks on application:
 - evaporator fan max. 200W
 - condenser fan max. 100W

Motor

Motor type	variable speed
Resistance, all 3 windings (25°C) Ω	0.1

Design

Displacement cm ³	3.86
Oil quantity (type) cm ³	280 (polyolester)
Maximum refrigerant charge g	400
Free gas volume in compressor cm ³	1690
Weight - Compressor/Electronic unit kg	7.9 / 0.33 / 0.28 (101N820)

Battery protection settings

Voltage	Min. value	Default	Max. value
Cut out (0.1 steps) VDC	9.6	10.4	17
Cut in diff. (0.1 steps) VDC	0.5	1.3	10

Dimensions

Height mm	A	173
	B	169
	B1	-
	B2	-
Suction connector location/I.D. mm angle	C	6.2 90°
	material comment	Cu-plated steel Al cap
Process connector location/I.D. mm angle	D	6.2 31.5°
	material comment	Cu-plated steel Al cap
Discharge connector location/I.D. mm angle	E	5.0 28°
	material comment	Cu-plated steel Al cap
Connector tolerance I.D. mm		±0.09, on 5.0 +0.12/+0.20

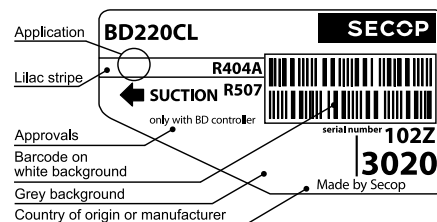

- S = Static cooling normally sufficient
- O = Oil cooling
- F₁ = Fan cooling 1.5 m/s
(compressor compartment temperature equal to ambient temperature)
- F₂ = Fan cooling 3.0 m/s necessary
- SG = Suction gas cooling normally sufficient
- = not applicable in this area

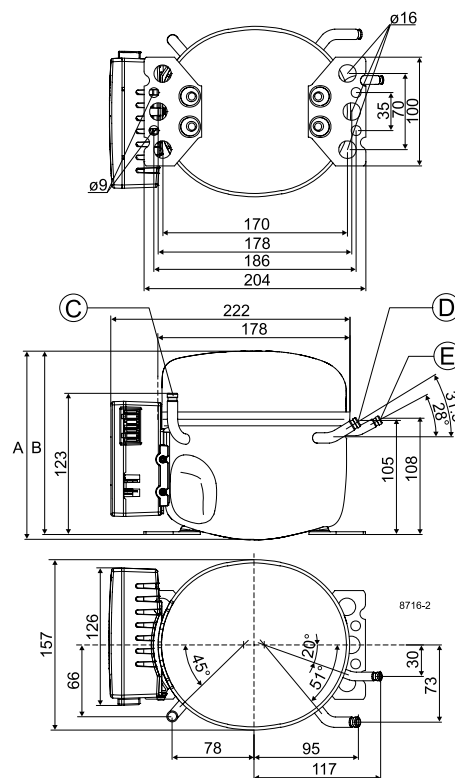

Capacity (EN 12900 Household/CECOMAF) 12V DC, fan cooling F₁ watt

rpm \ °C	-45	-40	-35	-30	-25	-23.3	-20	-15	-10	-6.7	-5	0
2,500	26,4	47,1	71,9	101	136	149	177	224	278	318	340	
3,000	31,4	56,0	85,5	121	162	178	210	266	331	379	405	
3,500	36,3	64,9	99,2	140	188	206	244	309	384	439	470	
4,000	40,8	73,1	112	158	212	232	275	349	433	495	530	

Capacity (ASHRAE LBP) 12V DC, fan cooling F₁ watt

rpm \ °C	-45	-40	-35	-30	-25	-23.3	-20	-15	-10	-6.7	-5	0
2,500	31	55	83	117	158	173	205	260	323	370	396	
3,000	36	65	99	140	188	206	244	310	385	441	472	
3,500	42	75	115	162	218	239	284	360	447	512	547	
4,000	47	85	130	183	246	270	320	405	504	577	617	

Power consumption 12V DC, fan cooling F₁ watt

rpm \ °C	-45	-40	-35	-30	-25	-23.3	-20	-15	-10	-6.7	-5	0
2,500	65.2	82.8	98.9	114	129	133	143	158	174	185	191	
3,000	75.2	96.0	115	134	152	158	170	190	210	225	233	
3,500	84.3	108	131	152	174	181	196	219	245	263	272	
4,000	94.3	121	147	172	197	206	223	251	281	303	314	

Current consumption 12V DC, fan cooling F₁ A

rpm \ °C	-45	-40	-35	-30	-25	-23.3	-20	-15	-10	-6.7	-5	0
2,500	5.43	6.90	8.24	9.50	10.71	11.12	11.92	13.16	14.48	15.40	15.90	
3,000	6.27	8.00	9.62	11.16	12.67	13.19	14.20	15.81	17.53	18.75	19.42	
3,500	7.03	9.02	10.89	12.69	14.48	15.10	16.32	18.27	20.38	21.89	22.71	
4,000	7.86	10.12	12.26	14.34	16.43	17.15	18.59	20.90	23.41	25.22	26.20	

COP (EN 12900 Household/CECOMAF) 12V DC, fan cooling F₁ W/W

rpm \ °C	-45	-40	-35	-30	-25	-23.3	-20	-15	-10	-6.7	-5	0
2,500	0.41	0.57	0.73	0.89	1.06	1.12	1.23	1.42	1.60	1.72	1.78	
3,000	0.42	0.58	0.74	0.90	1.07	1.12	1.23	1.40	1.57	1.68	1.74	
3,500	0.43	0.60	0.76	0.92	1.08	1.14	1.25	1.41	1.57	1.67	1.72	
4,000	0.43	0.60	0.76	0.92	1.08	1.13	1.23	1.39	1.54	1.64	1.68	

COP (ASHRAE LBP) 12V DC, fan cooling F₁ W/W

rpm \ °C	-45	-40	-35	-30	-25	-23.3	-20	-15	-10	-6.7	-5	0
2,500	0.47	0.66	0.84	1.03	1.23	1.30	1.43	1.65	1.86	2.00	2.07	
3,000	0.48	0.68	0.86	1.05	1.24	1.30	1.43	1.63	1.83	1.96	2.02	
3,500	0.50	0.69	0.88	1.07	1.26	1.32	1.45	1.64	1.83	1.95	2.01	
4,000	0.50	0.70	0.88	1.06	1.25	1.31	1.43	1.62	1.79	1.91	1.96	

Test conditions	EN 12900/CECOMAF	ASHRAE LBP
Condensing temperature	45°C	45°C
Ambient temperature	32°C	32°C
Suction gas temperature	32°C	32°C
Liquid temperature	no subcooling	32°C

Operational errors

Error code	Error type
	Can be read out in the software TOOL4COOL®
6	Thermostat failure (If the NTC thermistor is short-circuit or has no connection, the electronic unit will enter manual mode).
5	Thermal cut-out of electronic unit (If the refrigeration system has been too heavily loaded, or if the ambient temperature is high, the electronic unit will run too hot).
4	Minimum motor speed error (If the refrigeration system is too heavily loaded, the motor cannot maintain minimum speed at approximately 1,850 rpm).
3	Motor start error (The rotor is blocked or the differential pressure in the refrigeration system is too high).
2	Fan over-current cut-out (The fan loads the electronic unit with too high current).
1	Battery protection cut-out (The voltage is outside the cut-out setting).

Accessories for BD220CL

Mounting	Code number
Bolt joint for one compressor Ø: 16 mm	118-1917
Bolt joint in quantities Ø: 16 mm	118-1918
Snap-on in quantities Ø: 16 mm	118-1919

Electrical (cables, sensors, etc.)	Code number	
	Single pack	I - Pack
One Wire/LIN gateway	105N9501	-
communication cable	105N9524	-
Bluetooth® gateway	105N9502	-
communication cable	105N9525	-
Temperature sensor 470 mm	105N9612	105N9613, 200 pcs.
Temperature sensor 1000 mm	105N9614	105N9615, 100 pcs.
Temperature sensor 1500 mm	105N9616	105N9617, 100 pcs.
Comm. cable, 1500 mm	-	105N9553, 80 pcs.
Comm. cable, 3000 mm	-	105N9554, 45 pcs.
Display cable, 1500 mm	-	105N9557, 65 pcs.
Display cable, 3000 mm	-	105N9558, 35 pcs.

Not deliverable from Secop	
Slow-blow fuse compressor module	60A
Slow-blow fuse application module	30A
Main switch	rated to min. 100A

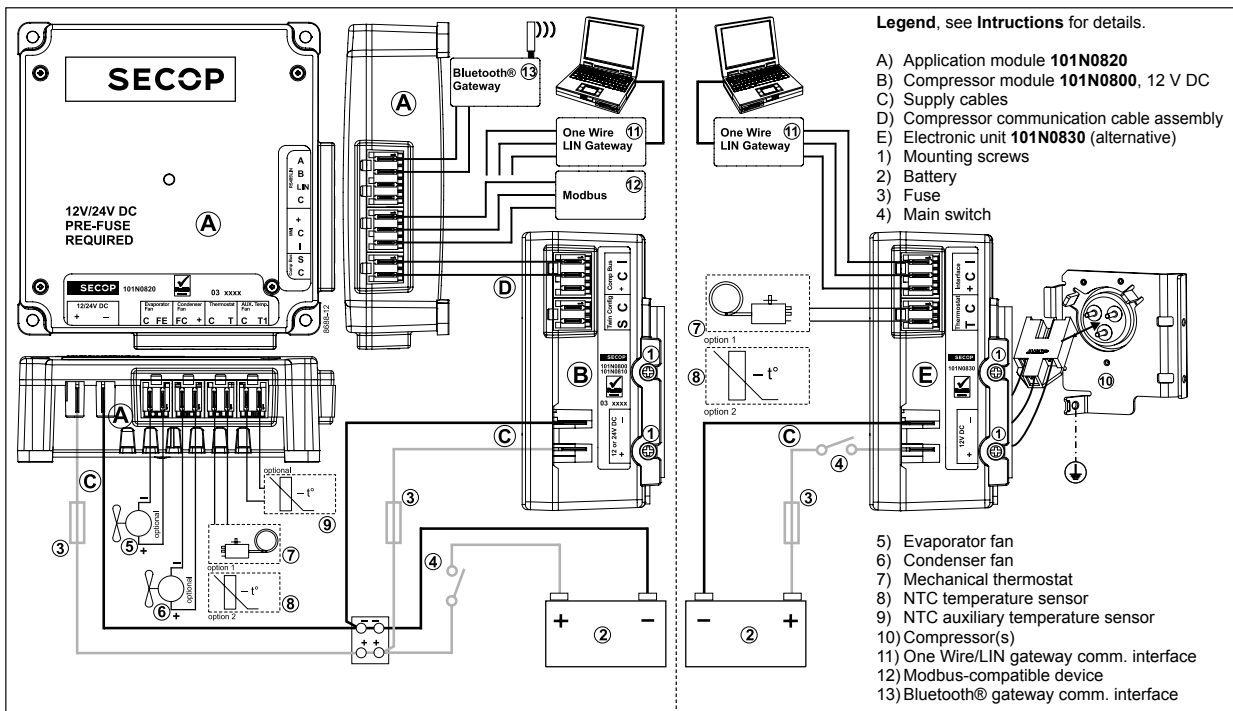

Danfoss Commercial Compressors

is a worldwide manufacturer of compressors and condensing units for refrigeration and HVAC applications. With a wide range of high quality and innovative products we help your company to find the best possible energy efficient solution that respects the environment and reduces total life cycle costs.

We have 40 years of experience within the development of hermetic compressors which has brought us amongst the global leaders in our business, and positioned us as distinct variable speed technology specialists. Today we operate from engineering and manufacturing facilities spread across three continents.



Danfoss Scrolls



Danfoss Inverter Scrolls



Danfoss Maneurop Reciprocating Compressors



Secop Compressors for Danfoss



Danfoss Turbocor Compressors



Danfoss Optyma Condensing Units

Our products can be found in a variety of applications such as rooftops, chillers, residential air conditioners, heatpumps, coldrooms, supermarkets, milk tank cooling and industrial cooling processes.

<http://cc.danfoss.com>

Danfoss Commercial Compressors, BP 331, 01603 Trévoux Cedex, France | +334 74 00 28 29



Danfoss can accept no responsibility for possible errors in catalogues, brochures and other printed material. Danfoss reserves the right to alter its products without notice. This also applies to products already on order provided that such alterations can be made without subsequential changes being necessary in specifications already agreed. All trademarks in this material are property of the respective companies. Danfoss and the Danfoss logotype are trademarks of Danfoss A/S. All rights reserved.